



ClearSpan™ Economy Moo-Tel™



Photo may show a different but similar model. The optional end panels (additional purchase required) are shown. Actual building may differ.

©2018 ClearSpan™
All Rights Reserved. Reproduction is
prohibited without permission.



WARNING: Cancer and Reproductive Toxicity - P65Warnings.ca.gov

STK#	DIMENSIONS
107404	20' W x 12' H x 24' L
107405	20' W x 12' H x 36' L
107406	20' W x 12' H x 48' L

Revision date: 01.26.18



YOU MUST READ THIS DOCUMENT BEFORE YOU BEGIN TO ASSEMBLE THE SHELTER.

Thank you for purchasing this ClearSpan™ shelter. When properly assembled and maintained, this product will provide years of reliable service. These instructions include helpful hints and important information needed to safely assemble and properly maintain the shelter. Please read these instructions **before** you begin.

If you have any questions during the assembly, contact Customer Service for assistance.

SAFETY PRECAUTIONS

- Wear eye protection.
- Wear head protection.
- Wear gloves when handling metal tubes.
- Use a portable GFCI (Ground Fault Circuit Interrupter) when working with power tools and cords.
- Do not climb on the shelter or framing during or after construction.
- Do not occupy the shelter during high winds, tornadoes, or hurricanes.
- Provide adequate ventilation if the structure is enclosed.
- Do not store hazardous materials in the shelter.
- Provide proper ingress and egress to prevent entrapment.

ANCHORING INSTRUCTIONS

Prior to assembling this shelter, please read the **MUST READ** document included with the shipment.

⚠ WARNING: The anchor assembly is an integral part of the shelter construction. Improper anchoring may cause shelter instability and failure of the structure. Failing to anchor the shelter properly *will void the manufacturer's warranty* and may cause serious injury and damage.

LOCATION

Choosing the proper location is an important step before you begin to assemble the structure.

The following suggestions and precautions will help you determine whether your selected location is the best location.

- Never erect the structure under power lines.
- Identify whether underground cables and pipes are present *before* preparing the site or anchoring the structure.
- Location should be away from structures that could cause snow to drift on or around the building.
- Do not position the shelter where large loads such as snow and ice, large tree branches, or other overhead obstacles could fall.

SITE

After choosing a location, proper preparation of the site is essential. Follow the information below.

- *A level site is required.* The site must be level to properly and safely erect and anchor the structure.
- For sites that are not concrete or gravel, placing wood blocks or other suitable supports under each rafter leg helps prevent the pipes from sinking or working into the site.
- Drainage: Water draining off the structure and from areas surrounding the site should drain away from the site to prevent damage to the site, the structure, and contents of the structure.

⚠ WARNING: The individuals assembling this structure are responsible for designing and furnishing all temporary bracing, shoring and support needed during the assembly process. For safety reasons, those who are not familiar with recognized construction methods and techniques must seek the help of a qualified contractor.

ASSEMBLY PROCEDURE

Following the instructions as presented will help ensure the proper assembly of your shelter. Failing to follow these steps may result in an improperly assembled and anchored shelter and will void all warranty and protection the owner is entitled to.

The steps outlining the assembly process are as follows:

1. Verify that all parts are included in the shipment. Notify Customer Service for questions or concerns.
2. Read these instructions, the Must Read document, and all additional documentation included with the shipment **before** you begin assembling the shelter.
3. Gather the tools, bracing, ladders (and lifts), and assistance needed to assemble the shelter.
4. Check the weather **before** you install the roof cover and any panels (if equipped). Do not install covers or panels on a windy or stormy day.
5. Re-evaluate the location and site based on the information and precautions presented in the documentation included with the shipment.
6. Prepare the site (if applicable).
7. Assemble the frame components in the order they are presented in these instructions.
8. Assemble the frame including the struts (if equipped).
9. Consult the MUST READ document and properly anchor the assembled frame.
10. Install, tighten, and secure the end panel and main cover (if equipped). This applies to fabric covers that stretch over the frame assembly. Your shelter may include roof panels or side panels or both.
11. Read the care and maintenance information at the end of these instructions.
12. Complete and return all warranty information as instructed.

LIST OF WORDS AND PHRASES

Before you begin, it is important to become familiar with the words and phrases used in this instruction manual.

These words and phrases are common to most ClearSpan™ shelters and identify the different parts of the shelter. (Some are used in this document. Others may not apply to this particular shelter.) These terms describe the shipped parts and can also be found on the materials list/spec sheets included with the shipment. To aid in the assembly, read through the following definitions before you begin to assemble your shelter.

- **Conduit:** An assembly of pipes used to secure the main cover and end panels (if equipped). Purlins and some strut assemblies also consist of connected pipes to form a conduit. Each pipe joint of a conduit assembly is secured with a self-tapping Tek screw.
- **Coupler or Fitting:** A part of the frame assembly where legs, purlins and rafter pipes are inserted and secured. In most instances, 3-way and 4-way couplers are used. In some larger applications, couplers are used to secure the joints of the different rafter sections during the assembly of the rafters. Some shelters do not use couplers.
- **Foot or Rafter Foot:** The part attached to and found at the base of the rafter or leg of the shelter. Depending on the shelter, the foot is an optional purchase. Some shelters do not offer an optional foot. Some use 1-way connectors; other use ground posts.
- **Must Read Document:** This document includes building and shelter anchoring instructions, steps for end wall reinforcement, safety precautions, and notices and warnings. The Must Read document is sent with all shelters and buildings. If you did not receive a Must Read document, contact Customer Service to request one.
- **On-Center:** Term used to describe a measurement taken from the vertical center of the rafter or frame member to the vertical center of another.
- **Purlin:** The pipe assembly that runs perpendicular to the rafters or framework that supports the main cover. Purlins are found on the sides and roof areas of the assembled frame, are evenly spaced, and typically run from the front to the back of the shelter.
- **Plain or Straight Pipe:** A term used to describe a pipe that has the same diameter or width throughout its entire length.
- **Strut:** A strut is usually a length of pipe with two flattened ends and is used for diagonal bracing of the shelter frame. A strut is typically secured to the frame work by special brackets and bolts.
- **Swaged End or Swaged Pipe:** The term “swaged” refers to the tapered end of the pipe or tube. Swaged ends of a pipe can be inserted into couplers and the straight ends of other pipes.
- **Tek Screw:** A self-tapping fastener used to secure pipe joints and to fasten brackets to rafters.

CLEARSPAN™ ECONOMY MOO-TEL™

REQUIRED TOOLS

The following list identifies the main tools needed to assemble the shelter. Additional tools and supports may be needed depending on the structure, location, and application.

- Tape measure or measuring device
- Fine point marker to mark the location on tubing.
- Variable speed drill and impact driver (cordless with extra batteries works best)
- Wrench, ratchet and socket (recommended)
- Ropes long enough to reach over the frame.
- Hammers and gloves
- Metal file
- Duct tape (supplied by customer)
- Box cutter, utility knife or scissors
- Ladders, work platforms, and other machinery for lifting designed to work safely at the height of the frame

UNPACK AND IDENTIFY PARTS

The following steps will ensure that you have all the necessary parts before you begin to assemble the shelter frame.

1. Unpack the contents of the shipment and place where you can easily inventory the parts. Refer to the Bill of Materials/Spec Sheets.
2. Verify that all parts listed on the Bill of Materials/Spec Sheets are present. If anything is missing or you have questions, consult the Pictorial Parts Guide and all diagrams for clarification, or contact Customer Service.

NOTE: At this time, you do not need to open the plastic bags containing smaller parts such as fasteners or washers (if equipped).

QUICK START GUIDE

For a quick overview, consult the information and diagrams in the Quick Start Guide at the back of these instructions for your shelter before you begin.

SPECIAL NOTE: Baseboards for Frame

These instructions describe installing a baseboard (recommended) at ground level along each side of the frame. The baseboard runs from the front to the back of the frame.

This baseboard is *not included* with the shipment and must be supplied by the customer. Treated or recycled plastic lumber works well for a baseboard.

The baseboard, when installed properly, helps prevent the ground posts from sinking into the ground when anchored. Depending on the building, it also provides a surface to attach struts or other building components.

Consult these instructions, or contact Customer Service for additional information regarding baseboards.

ANTI-BILLOW ROPE INSTALLATION

TO PREVENT DAMAGE AND POSSIBLE INJURY, INSTALL THE ANTI-BILLOW ROPES IN SHORT LENGTHS ALONG EACH SIDE OF THE FRAME.

DO NOT INSTALL AS A SINGLE LENGTH TIED AT EACH END OF THE BUILDING. DOING SO WILL RESULT IN A LOOSE SIDE PANEL IF THE SINGLE ROPE BREAKS DURING STRONG WINDS.

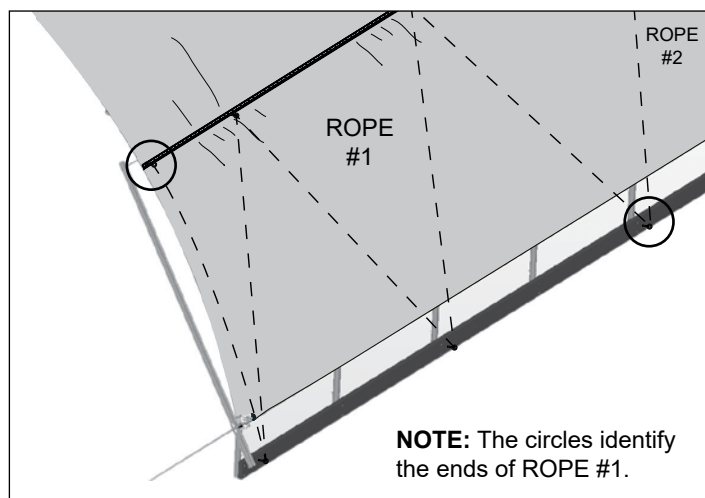

ClearSpan

The following graphics and photos will help you identify the different parts and show you how they are used. (Not all parts are shown.)



FA4482B
Tek Screw

102569
Bearing



102856
End Clamp



102548
Cross Connector



102717
Gearbox Drive

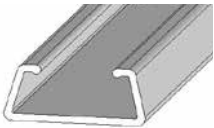

102197
Poly Latch U-Channel



102570
Aluminum Channel



102675
Ground Post



102568
Mounting Plate

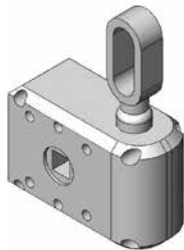

Gearbox



102198
U-Channel Spring

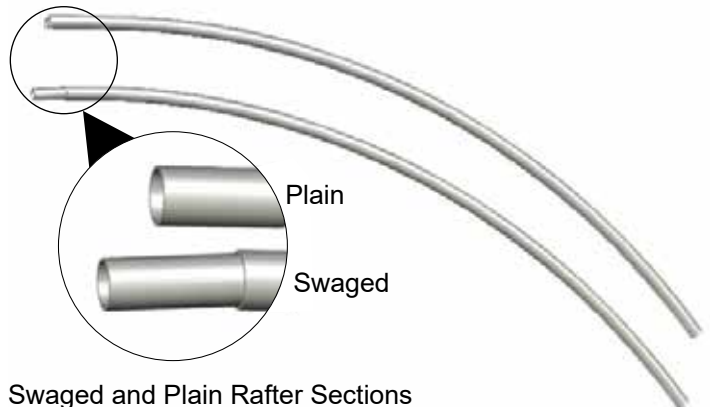

Swaged and Plain Rafter Sections
(not all pieces are shown)



Economy Moo-Tel™

OVERVIEW

This section is an overview of the process to assemble your building. For details, consult the "Assembling the Frame Components" section. See illustration below to identify main parts of building.

1. Locate the required parts for each assembly procedure.
2. Assemble the rafters and frame and square the frame.
3. Prepare and attach end panels (if equipped).
4. Attach main cover and Twist-of-the-Wrist assembly.

ATTENTION: Position purlins evenly during the frame assembly. Use the rafter pipe joints as guides when installing the end clamps, cross connectors, and purlins.

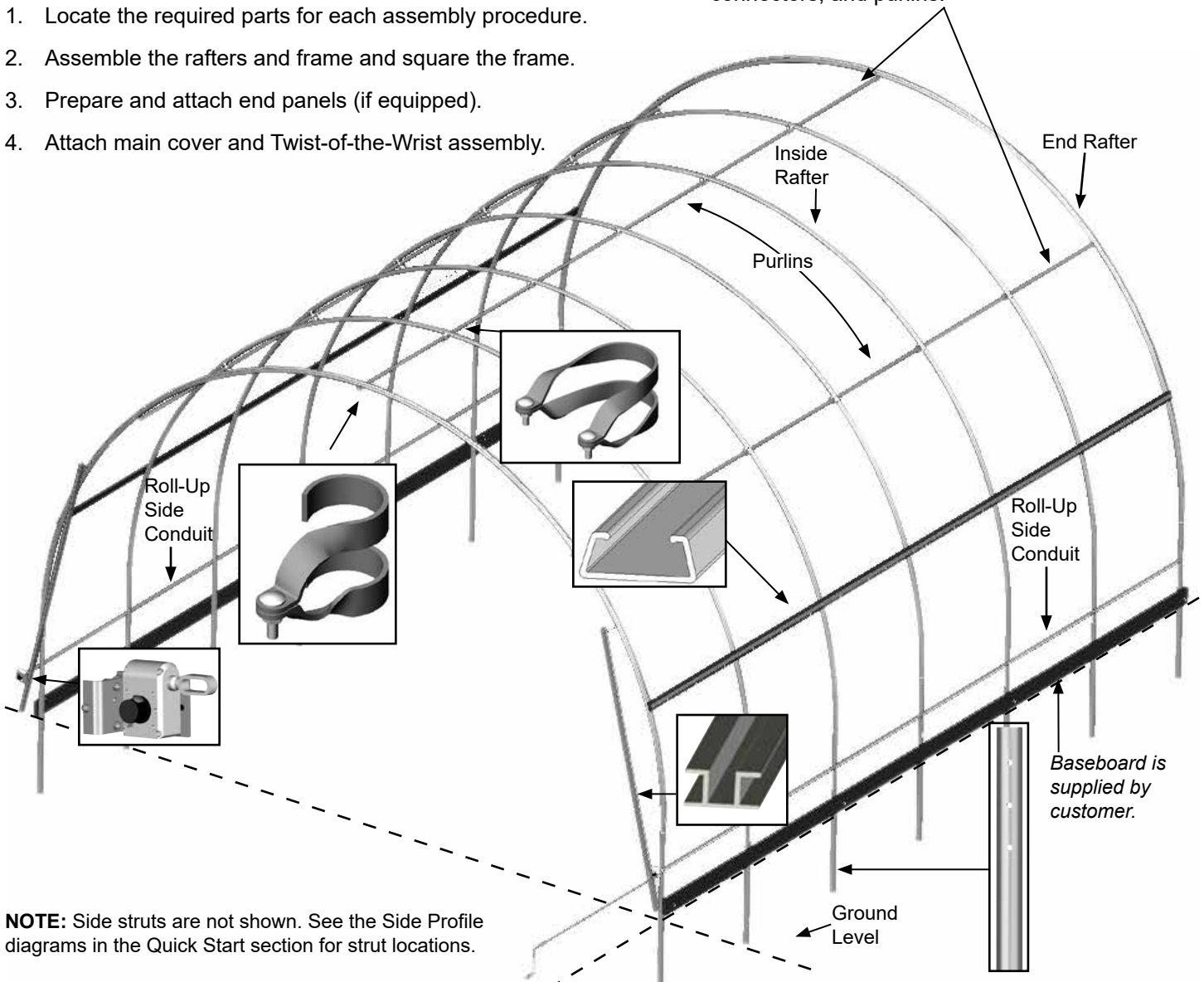

NOTE: Side struts are not shown. See the Side Profile diagrams in the Quick Start section for strut locations.

LAY OUT THE BUILDING SITE

After the site is prepared, lay out the building site.

Taking these steps **before** assembling the shelter saves time and ensures that the structure is positioned as desired.

Drive ground posts to the proper depth. Width of the shelter is measured from the center of one ground post to the center of the remaining ground post.

SQUARE THE SITE

Gather the parts:

- Ground posts
- 5/16" x 2-1/2" machine bolts
- 5/16" nuts

1. Identify a corner where a ground post will be positioned and drive the first ground post into the ground.

NOTE: Insert the ground post driver into the top of the ground post to protect the post and drive the post into the ground. *The top of the post will be one (1) foot above the finished grade when properly driven.*

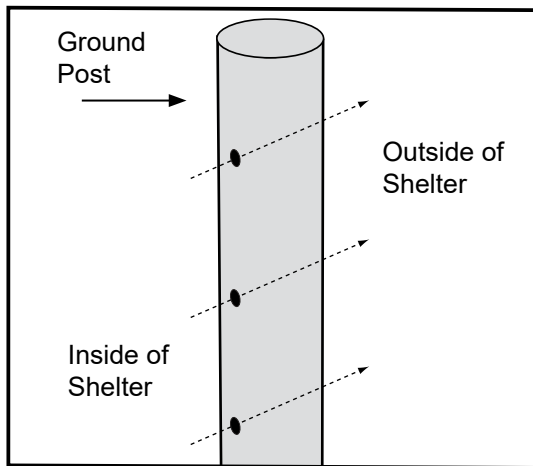

ATTENTION: Position the pre-drilled holes facing to the inside/outside of the shelter so they can be aligned with the bolt holes in the rafter legs.

To align the bolt holes in the ground posts with those in the rafter *after driving the ground posts*, insert a tapered rod or pry bar into a ground post bolt hole and turn the post using the rod or pry bar.

2. After the first corner ground post is in place, string a line the width of the building (center-to-center) and drive the second ground post into the ground just enough to hold it in place.
3. Use a transit or line level to drive the second corner post to the same depth as the first ground post.

4. Sting a line at least as long as the building from the first stake at 90°.

NOTE: A transit can be used to ensure an accurate 90° angle, or the 3-4-5 rule can be used. Refer to diagram. Using multiples of 3-4-5 such as 6-8-10 or 12-16-20 helps to maintain an accurate 90° angle.

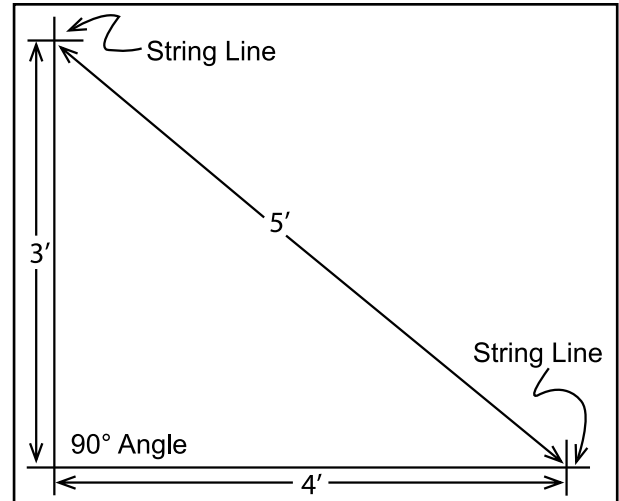

5. After squaring the position of the building, measure the length and drive the next corner ground post.
6. Repeat the same step for the last corner post.

NOTE: The distance measured diagonally between corner posts must be equal for the building to be square.

7. Check all dimensions (and adjust if needed) before driving the remaining posts to the required height.
8. After all corner posts are accurately installed, tie a string line between the tops of the corner ground posts on the same side of the shelter. The string is used to identify the tops of all remaining ground posts. The string must remain tight and level.
9. Use a tape measure to mark the 48" on-center locations of the remaining ground posts.
10. Drive the remaining ground posts into the ground at the required 48" on-center width and the height identified by the string.

NOTE: Verify that the holes in the ground posts are in the proper position and that each post is plumb and driven to the correct depth.

After the rafters have been assembled, the rafter ends are secured to the ground post using the upper hole.

The bottom two (2) holes on the ground post are used for the optional baseboards.

11. Continue with the **Rafter Assembly** steps that follow.

CLEARSPAN™ ECONOMY MOO-TEL™

ASSEMBLING THE FRAME COMPONENTS

NOTE: Assistance is required to assemble the shelter frame.

RAFTER ASSEMBLY

Gather the parts:

- Rafter pipe #20R1601
- Rafter pipe #20R1602
- Rafter pipe #166S027D
- End clamps
- Tek screws
- Nut setter (3/8" x 2-9/16 magnetic)

Rafter Assembly Procedure

Each rafter assembly consists of six (6) rafter sections: three (3) swaged sections, one (1) plain section, and a pair of swaged extensions.

1. Select the six (6) pipes needed to assemble a rafter and arrange these on a flat surface as shown below for assembly.

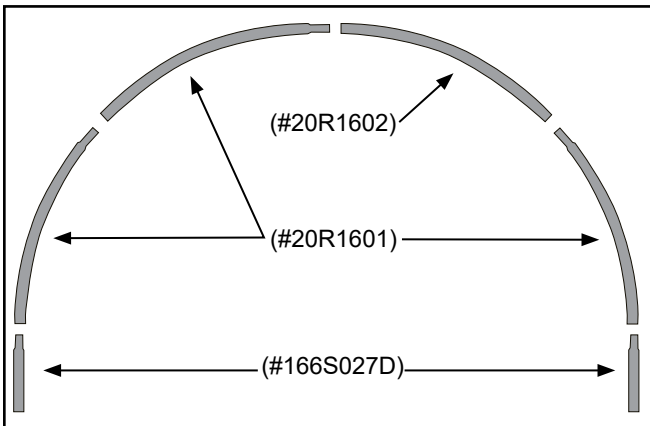

2. Slide the swaged portion of each rafter pipe into the plain end of the pipe as shown.

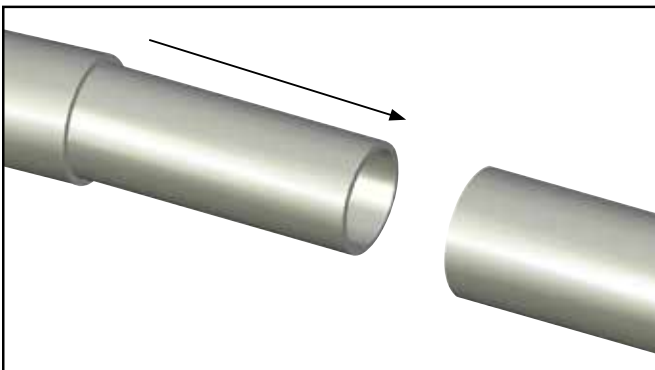

3. With the main rafter pipes seated at each joint and the rafter positioned on a flat surface, secure each joint with a single self-tapping Tek screw.

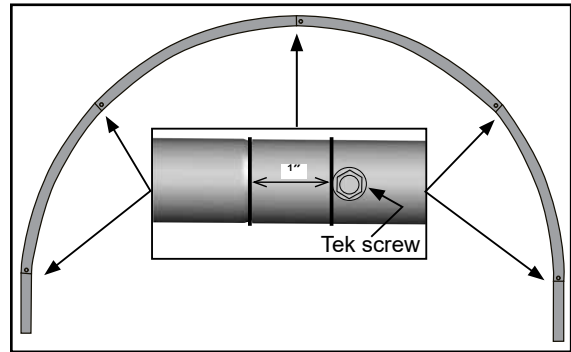

ATTENTION: Do not secure the drilled leg pipes until rafter is secured to the ground posts. This allows holes in rafter legs to be aligned with those in ground post. Install the screws so they will not touch the cover once it is installed. This is typically on the backside of the rafter, which will be the surface visible from the *inside* of the shelter once the frame is assembled.

4. Assemble rafters as described and continue with the additional steps to complete the assembly of the two (2) end rafters.

END RAFTER ASSEMBLY

In addition to the steps in the previous procedure, complete the following steps *for the two (2) end rafters only*.

1. Take one of the assembled rafters and place it on a flat surface.
2. Slide three (3) end clamps onto the rafter in the locations noted below. (Do not secure the clamps to the rafter at this time. These clamps are repositioned during the frame assembly to add the purlins.)

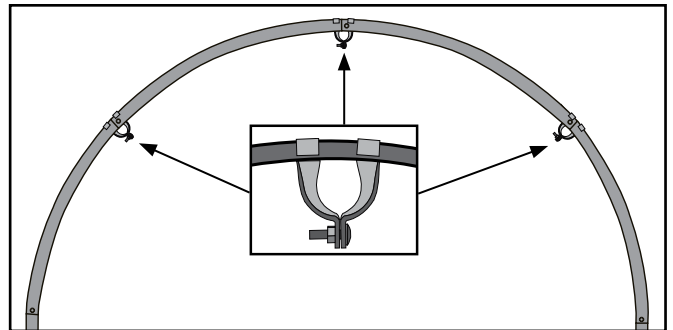

NOTE: Position all clamps as shown. Use a piece of duct tape (if desired) to keep each clamp from sliding when the rafter is lifted into position.

View of the end rafter and clamps as shown from the *outside* when the frame is assembled.

3. Repeat the same procedure for the final end rafter.
4. Continue with the **Frame Assembly** instructions that follow.

FRAME ASSEMBLY

Gather the parts:

- All rafter assemblies
- Pipe 1.315" x 75" swaged (#131S075)
- Pipe 1.315" x 73.5" plain (#131P0735)
- 5/16" x 2-1/2" machine bolts and 5/16" nuts
- Lifts, ladders, and assistants

Frame Assembly Procedure

1. Using the proper lifts and with assistance, carefully stand the *first end rafter assembly* and place the leg pipes into the first set of ground posts.

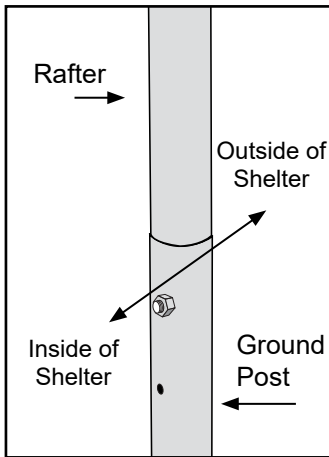

IMPORTANT: Brace the first rafter in position as needed to keep it from moving. Bracing is removed *after* additional rafters are installed and secured to the other rafters.

2. Secure the leg pipes to the ground posts using the 5/16" x 2-1/2" machine bolts and nuts.
3. Place an *interior rafter assembly* into a second set of ground posts. Secure the leg pipes to the ground posts as previously described.
4. Position two (2) cross connectors near the top of the interior rafter assembly as shown below.

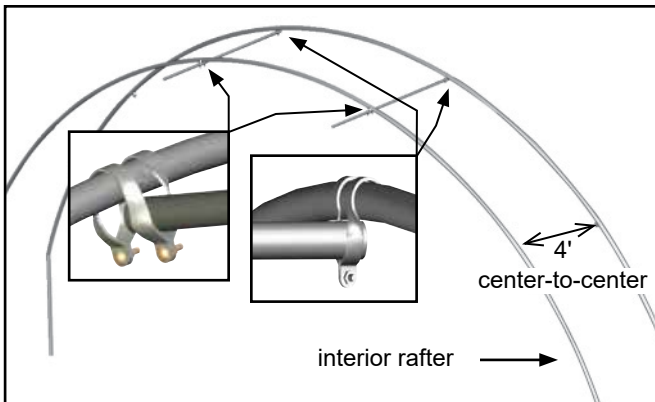

5. Take two (2) swaged 75" purlin sections and insert each through an upper clamp on the end rafter and through the cross connectors near the top of the interior (or second) rafter as shown above.

6. Verify that both rafters are plumb and properly spaced (4' on center).
7. Tighten the upper cross connectors on the interior rafter and tighten the end clamps near the top of the end rafter to secure the first purlin pipes.

NOTE: Do not allow the purlin to extend beyond the end of the end rafter. See diagram below.

8. Continue adding rafters and purlin pipe until the frame is assembled. Secure all purlin splices using Tek screws. See Step 10.

NOTE: Each purlin assembly consists of 1.315" x 75" (#131S075) swaged pipes (number is determined by shelter length) and one (1) 1.315" x 73.5" (#131P0735) plain pipe.

9. Finish each purlin run using the plain, shorter pipe (#131P0735) and use the final end rafter to complete the assembly.

NOTE: If the last end rafter is plumb and the purlin run extends beyond the end of the rafter, cut the last section of purlin pipe to the required length. Typically purlin pipes *do not* require cutting. *Verify that you have the correct plain pipes before you decide to cut any pipe to complete the purlin runs.*

CAUTION: To prevent cover damage, the ends of the purlins should extend no more than 1/2" past the end clamp. Position the bolt side of the end clamps toward the "inside" of the shelter (the same side as the purlin).

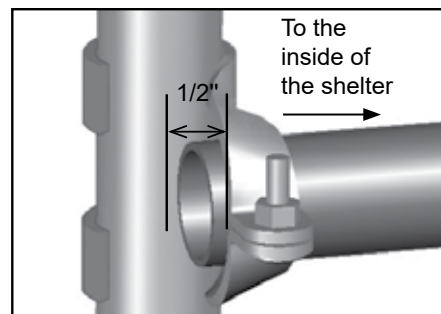

10. Once all rafters are set and all purlins are in place and secured, return to each pipe splice of each purlin run and install a Tek screw through the pipes to secure the joints if this was not completed during assembly.

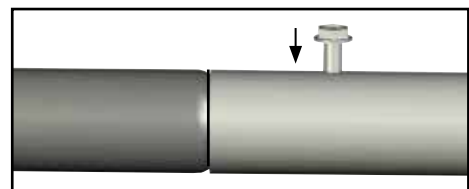

11. Return to each rafter and, using Tek screws, secure the joint between the lower rafter legs (drilled pipe) and the upper rafter pipes and continue with the following procedure. *Secure all rafter joints using a Tek screw.*

CLEARSPAN™ ECONOMY MOO-TEL™

BASEBOARD INSTALLATION (RECOMMENDED)

Gather the parts:

- Treated or recycled plastic lumber (supplied by customer).
- 1/4" x 4" carriage bolts and 1/4" nuts

NOTE: The following procedure describes one way to install the recommended baseboards. The size and type of the baseboard you choose may require the use of alternative steps. When properly installed, baseboards run the length of the frame.

On the outside of the frame, attach the first baseboard to the ground posts using the 1/4" x 4" carriage bolts and nuts. Continue adding baseboards to complete the first run. Splices are made between posts as shown. Use a short section of baseboard to secure separate baseboards at a splice.

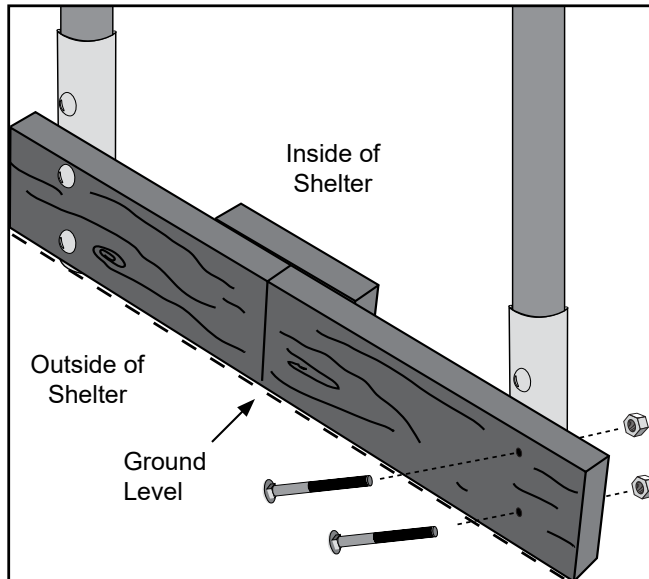

NOTE: The boards should be at ground level or slightly into grade to prevent the shelter from sinking and to create a seal along the bottom. After installing the baseboards, continue with these instructions.

This baseboard is *not included* with the shipment and must be supplied by the customer. Treated or recycled plastic lumber works well for a baseboard.

The baseboard, when installed properly, helps prevent the ground posts from sinking into the ground when anchored. Depending on the building, it also provides a surface to attach struts or other building components.

SIDE STRUT INSTALLATION

Side struts are positioned *between the end rafters and the first interior rafter on each side of the shelter*. The lower end of the strut is attached to the customer-supplied baseboard (if used) or to the first interior rafter at the top of the ground post using a band clamp.

Gather the Parts

- Struts and band clamps
 - Lag screws or nut and bolt (supplied by customer)
1. Place a band clamp around the end rafter leg. Use a channel lock pliers to squeeze the band clamp back into shape after installation if needed.
 2. Locate one strut and position it between one end rafter leg and the leg of the first interior rafter as shown below.

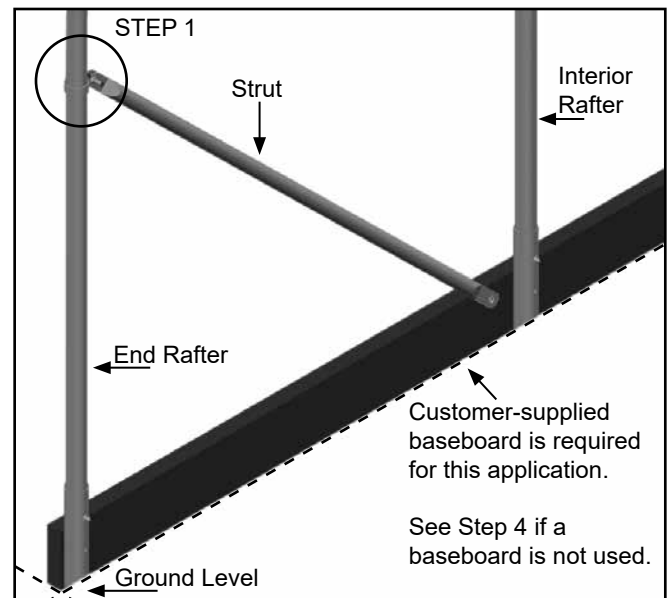

3. Attach the upper end of the strut to the band clamp as shown in the diagram below.

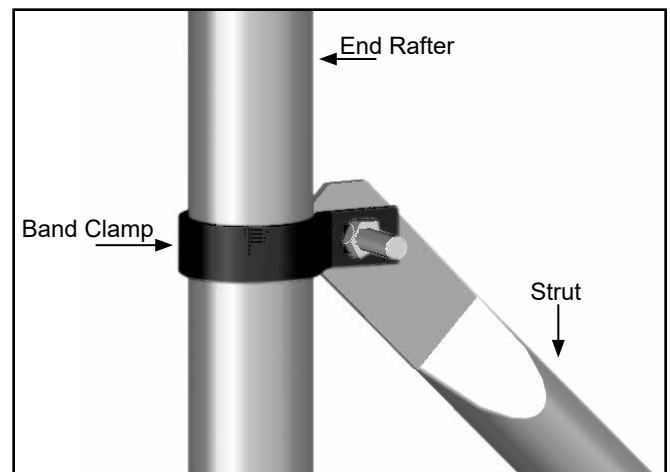

NOTE: Position the head of bolt to the outside of the frame to prevent cover damage.

- Attach the remaining end of the strut to the baseboard using a lag screw or nut and bolt (not included). See the diagram that follows for location.

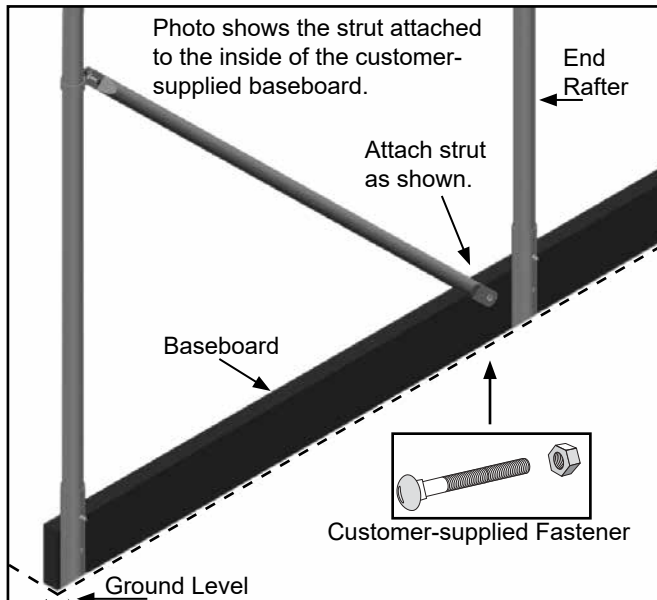

NOTE: A baseboard helps keep the ground posts at the required depth. The customer supplies the fasteners to attach the strut to a customer-supplied baseboard.

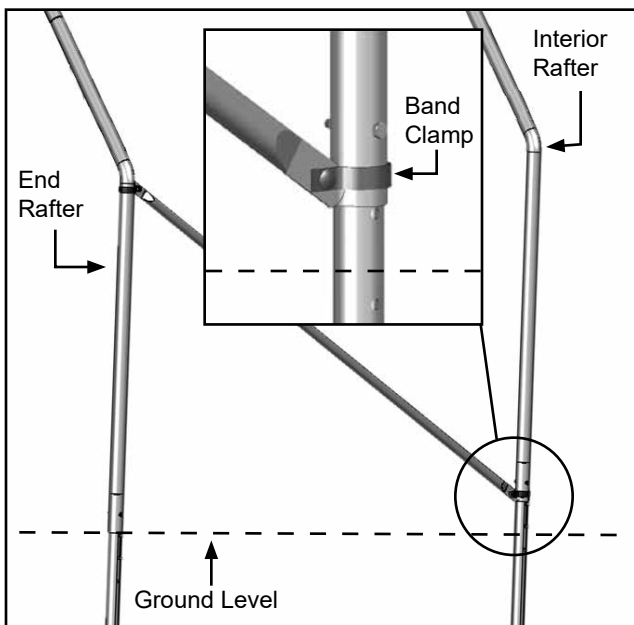

If a baseboard is not present, install another band clamp around the interior rafter leg (see insert above) and attach the lower end of the strut to that band clamp. *Rafter design shown above may differ from actual rafter and frame of your building.*

- Repeat the above steps to attach the remaining side struts to the frame.
- After installing the struts, verify that all band clamps are secured to the rafters using a Tek screw.
- Continue by checking the frame for sharp edges.

FINISH ROUGH EDGES

Gather the parts:

- Duct tape (supplied by customer)
- Metal file

- Check for any sharp edges on the frame and file them smooth so they will not cut the cover.

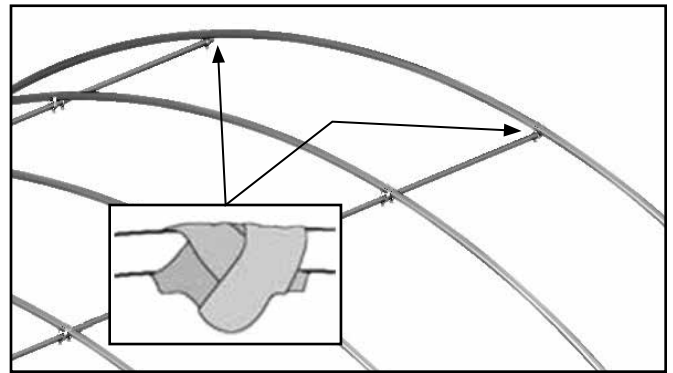

- Apply two layers of heavy duct tape on all pipe connections and clamps that may contact the cover.
- Continue by anchoring the assembled frame.

ANCHOR THE ASSEMBLED FRAME

At this point, anchor the frame. Consult the MUST READ document for anchoring information and suggestions. Please call customer service at 1-800-245-9881 for additional anchoring information.

CAUTION: The anchor assembly is an integral part of the construction. Improper anchoring may cause instability and failure of the structure to perform as designed. Failing to anchor the shelter properly will void the manufacturer's warranty and may cause serious injury and damage.

CLEARSPAN™ ECONOMY MOO-TEL™

END PANEL INSTALLATION (if purchased)

These instructions describe installing the optional end panels if equipped. If you want to purchase end panels for your Economy Moo-Tel™ building, contact your knowledgeable sales representative. *For a building without end panels, skip to and continue with the main cover installation.*

⚠ CAUTION: To prevent damage, do not install end panels on a windy day.

Gather the parts:

- End panels
- Fabric clips #CC6213 (Divide the quantity in half.)
- Measuring tape and scissors or similar cutting tool

Assembly Procedure

1. Spread an end panel out on the ground at the desired end of the frame and center the end panel as needed.
2. With the proper lift (or ladders) positioned inside the frame, pull the end panel up and over the top of the end rafter.
3. Secure the end panel to the backside of the end rafter at the top, center position using a fabric clip and Tek screw.
4. Moving outward in both directions, continue attaching fabric clips to secure the end panel to the rafter. Evenly space the fabric clips and work toward the ground.

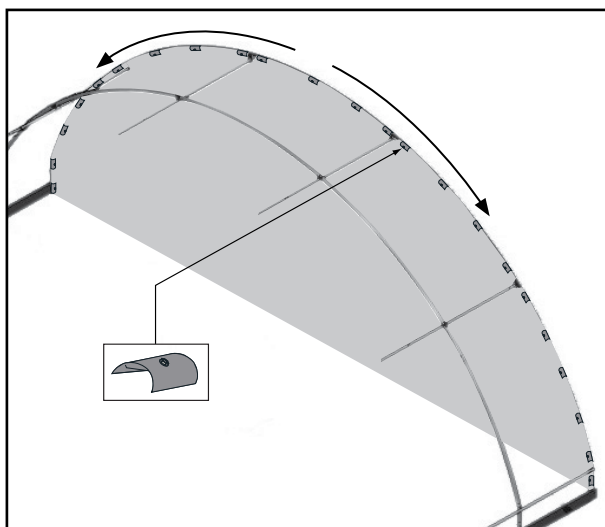

5. Verify that the end panel is in the desired position and repeat the steps to secure the other end panel to the frame using the remaining half of the fabric clips.

NOTE: The end panels may be shipped as untrimmed rectangular pieces. If so, use scissors to trim the excess end panel material from inside the frame after attaching the panels to the end rafters.

MAIN COVER INSTALLATION

After installing the end panels (if equipped), install the main cover. The steps to install the main cover include:

1. Attach poly latch U-Channel along the shelter sides and tops of the shelter end rafters.
2. Pull main cover over the frame.
3. Attach the main cover to the end rafters using the poly latch springs.
4. Stretch and attach main cover to the sides of the frame.
5. Install roll-up side kits and test the operation of the twist-of-the-wrist assembly.

INSTALL POLY LATCH U-CHANNEL

1. Measure the desired height (4'-5') to identify the top of the roll-up sides.

NOTE: Attach the poly latch channel at approximately 4'-5' above the ground on both sides of the frame.

Attaching a ribbon board to the rafters and then attaching the poly-latch U-Channel to the ribbon board is recommended for the best results. Consult the diagram below for clarification.

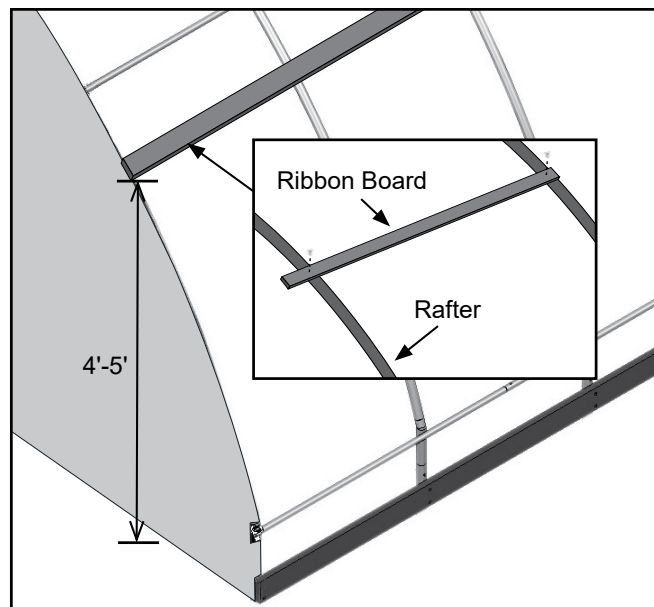

NOTE: Ribbon board and baseboard (recommended) shown in the diagram above *are not included* and are supplied by the customer. If used, the ribbon board and baseboard are supplied by the customer.

INSTALL POLY LATCH U-CHANNEL (Continued)

- Attach one section of the poly latch U-Channel to the side of the frame using Tek screws. Attach U-Channel flush with the outside edge of the end rafter at each end of the assembled frame.

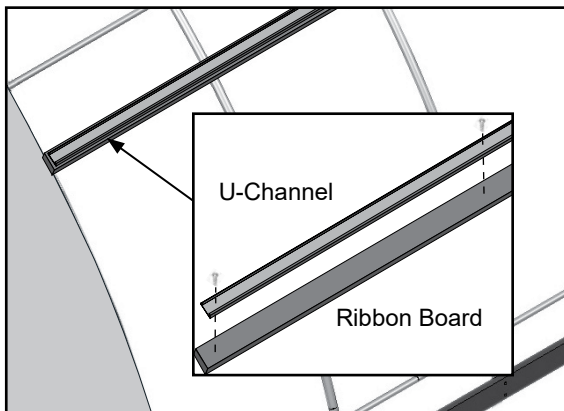

- Continue to attach the U-Channel sections to the rafters (or ribbon board if used) and work toward the other end of the frame. Cut the last section of U-Channel to the required length so that it is flush with the outside edge of the end rafter.
- Repeat these steps for the remaining side.
- After attaching the poly latch U-Channel to the sides of the frame, use Tek screws to attach the U-Channel to the top of one end rafter.

ATTENTION: The poly latch U-Channel will bend with the curve of the rafter as it is attached. The U-Channel runs from the poly latch U-Channel attached to one side of the frame to the U-Channel attached to the other side of the frame.

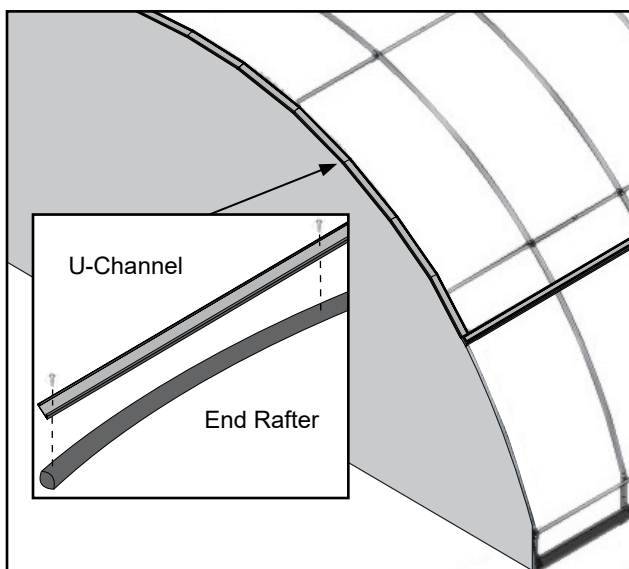

- Repeat the steps to attach the U-Channel to the top of the remaining end rafter and continue with the main cover installation.

INSTALL MAIN COVER

Gather the parts:

- Main cover
- Ropes long enough to reach over the frame (provided by customer)
- U-Channel spring (**Wear eye protection!**)
- Box cutter or utility knife

Assembly Procedure

After the poly latch U-Channel is attached to the frame, unpack the main cover and pull into place. Ropes or straps are typically used to pull the main cover onto and over the frame.

WARNING: To prevent damage to the cover and to prevent serious personal injury, DO NOT attempt to install the main cover on windy or stormy days.

- Unpack the main cover and position it at the base along one side of the frame.
- Make small holes along the edge of the cover at evenly spaced intervals and tie rope to the cover. (The length of the cover determines the number of holes that are needed to attach the ropes.)

NOTE: The ropes must be long enough to reach over the top of the building to the other side. Long buildings will require additional ropes to prevent tearing the main cover when it is pulled into place.

- After tying the ropes to the main cover, throw the ropes over the top of the frame and pull the cover into place. Cover must be centered side-to-side and end-to-end.

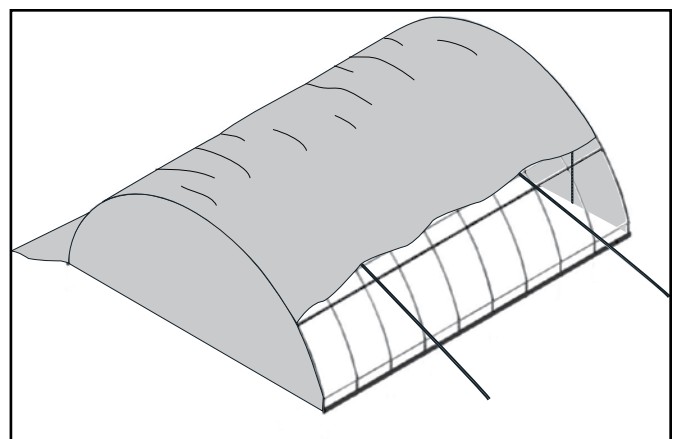

Shelter shown above may be a different length than actual shelter.

IMPORTANT: To prevent damage to the main cover during installation, additional personnel and lifts may be needed.

CLEARSPAN™ ECONOMY MOO-TEL™

- Once the main cover is in place and centered on the frame, begin at the peak of one end rafter and install the wire spring into the U-Channel to secure the cover.

ATTENTION: Center the main cover front to back and side-to-side to ensure that enough cover material is present to lock into the U-Channel. *The excess cover along each side is rolled up when the roll-up side assemblies are installed.*

The rope can remain in place to temporarily secure the cover if needed. Remove the ropes as the cover is secured to the frame.

Photos show installing the spring into the U-Channel on the outside of a frame. The process is the same for the U-Channel attached to the top of the end rafters.



- Continue adding the spring into the U-Channel at the top of the first end rafter. Ensure that an even amount of the cover is exposed and maintained along the edge of the frame as it is attached.

NOTE: The cover material is cut longer/wider than is required to cover the frame. For easier anchoring, allow approximately 10" to extend past the edge of the end rafter as the cover is anchored in place.

- Continue down both edges of the first end rafter until the entire length of the end of the main cover is secured in place.
- Stretch the cover to the other end of the building and repeat the steps to secure the main cover in the U-Channel, which is attached to the top of the end rafter.

NOTE: Pull the cover tight as the spring is inserted into the U-Channel.

- After the cover is stretched end-to-end and secured using the spring and U-Channel, move to one side of the frame and repeat the steps to anchor the main cover to the first side.

Begin at one end of the U-Channel and work toward the other. It is also possible to begin at the middle of each side and work toward each end.

NOTE: Maintain an even length along the side. The final stretching of the cover takes place when the last side is secured.

- After securing the first side, move to the remaining side and secure it in place.

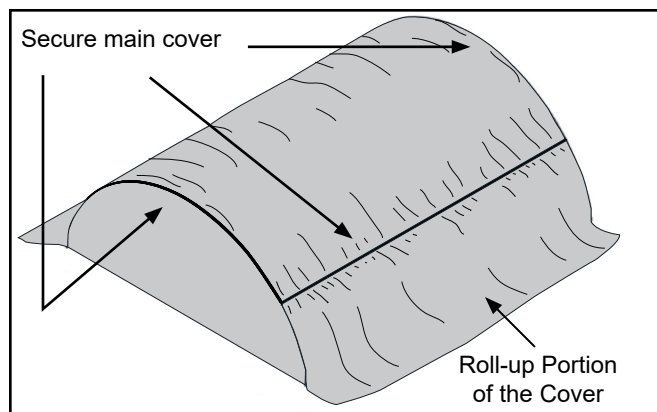

IMPORTANT: DO NOT REMOVE TOO MUCH OF THE EXCESS COVER MATERIAL AT EACH END. Some excess main cover material—the material that extends beyond the end rafters—should remain in place. If the main cover needs stretched in the future, remove the spring from the U-Channel, grasp the excess material, pull the cover tight, and reinstall the spring.

The excess material along the sides is rolled up in the roll-up side assembly.

- Once the main cover is installed and secured in the U-Channel, continue with the **Install the Roll-up Side Assemblies** procedure.

INSTALL THE ROLL-UP SIDE ASSEMBLIES

The instructions below describe how to install a single roll-up sidewall assembly for one side of the frame. The procedure is repeated for the remaining side.

The procedures to install the roll-up side include the following:

1. Assemble the roll-up side conduit.
2. Attach the roll-up conduit to the bottom of the main cover.
3. Assemble the Twist-of-the-Wrist assembly and attach it to the frame and the roll-up side.
4. Install the Anti-Billow Rope system.
5. Test the operation of the roll-up side.

INSTALL THE ROLL-UP SIDE CONDUIT

Gather the parts:

- Pipe 1.315" x 75" swaged (#131S075)
- Pipe 1.315" x 73.5" plain (#131P0735)
- Tek screws

The roll-up side conduit assembly is attached to the bottom of the roll-up side cover material. This assembly runs the length of the frame and serves as the center pipe that the roll-up cover wraps around when it is opened to ventilate the shelter. *This conduit is identical to the purlins that were assembled and attached to the frame.*

Complete these steps to assemble the roll-up side conduit.

1. Locate all sections of pipe needed to assemble the cover conduit.
2. Insert the swaged end of each pipe into the plain end of another pipe until the conduit is assembled.
3. Secure each pipe joint with a Tek screw.

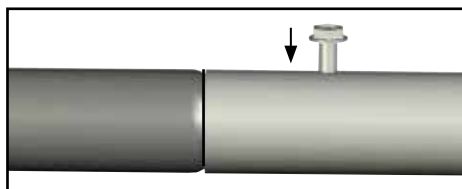

4. Place the assembled conduit at the base of the side where the end of the main cover is located.

NOTE: Duct tape Tek screws to prevent damage to main cover.

5. Continue with the procedure that follows to attach the conduit to the main cover.

ATTACH CONDUIT TO MAIN COVER ROLL-UP SIDE

Gather the parts:

- Assembled conduits
- Fabric clips #CC6212 (Divide quantity in half.)
- Tek screws

To this point, the main cover should be secured to the frame and the excess cover along both sides should be hanging down along the side of the frame.

1. Unfold the remaining portion of the main cover (if needed) and evenly stretch it out on the ground along the frame.
2. Working from *the inside the frame*, roll the assembled cover conduit onto the edge of the main cover.
3. Verify that the cover and conduit are evenly positioned and tuck the cover edge under the conduit and roll the conduit to wrap the cover around it one to two turns.

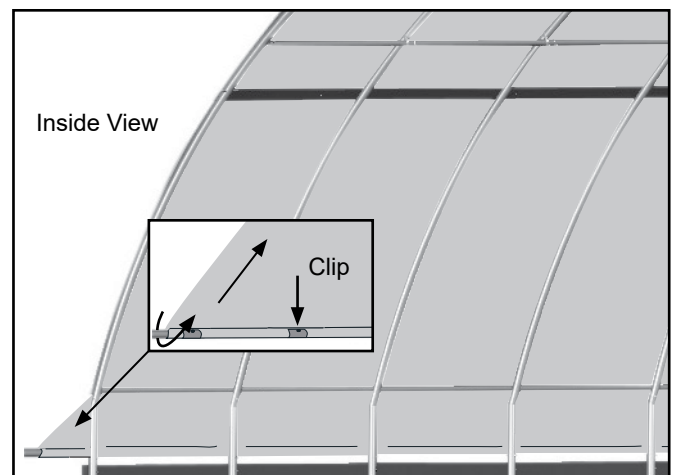

Shelter shown above may be a different model. Drawing used for illustration only.

4. Using one-half of the fabric clips (CC6212) and Tek screws, secure the cover film to the cover conduit. Evenly space the clips along the conduit for best results. See insert above.
5. Continue to roll the conduit until the excess cover material is wound around the conduit and the conduit is positioned on the ground at the base of the assembled frame.
6. With the excess cover material rolled onto the conduit assembly, continue with the **Twist-of-the-Wrist Assembly** procedure.

TWIST-OF-THE-WRIST ASSEMBLY

Gather the parts:

- Aluminum channel
- Drive handle
- Gearbox and gearbox drive
- Mounting plate
- Bearing and threaded rod
- 3/8" nuts and washers

The Twist-of-the-Wrist Assembly is designed to roll up a portion of the sides of the structure. The following steps describe the assembly and its installation.

1. Drill a 5/16" hole through the cover conduit 1/2" from the end of the conduit.
2. Insert a tubing adapter into the conduit and align the holes of the adapter with the drilled holes in the conduit.



3. Select the aluminum channel and drill a 3/8" hole through the channel approximately 2" from the end and attach a threaded rod using a 3/8" nut on each side of the channel.

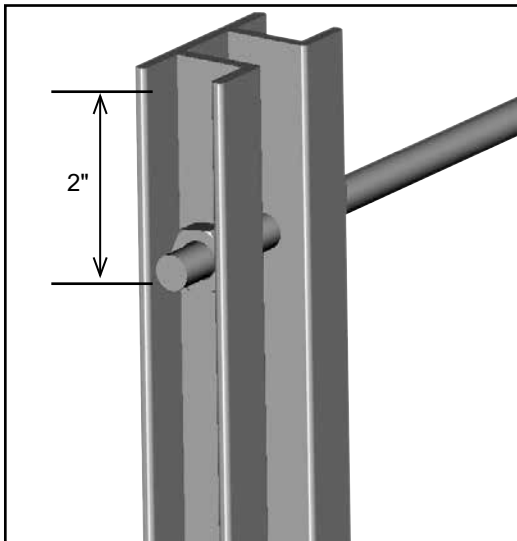

4. Position the channel along the end rafter at the end of the building where the Twist-of-the-Wrist assembly will be located.

NOTE: Verify that the lower end of the channel is slightly off the ground to allow it to move freely when the panel is rolled up and down.

5. Secure the upper end of the channel by drilling a 3/8" hole through the end rafter and attach as shown. The lower end of the channel will "float" and is not attached.

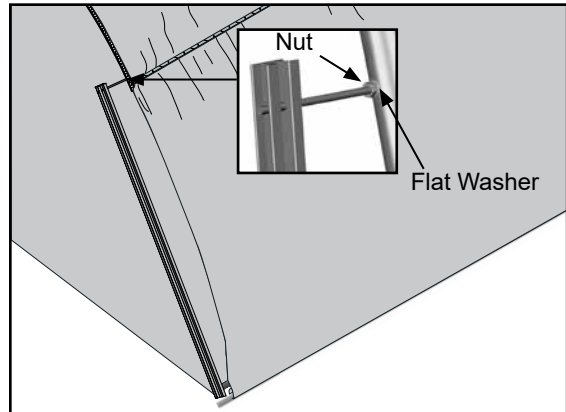

NOTE: Install a flat washer between the nut and the end panel (if equipped). Panel is not shown in the insert.

6. Select the bearing bracket and attach the bearings as needed. (In some instances, the bearings may come already attached.) Assemble as follows (if needed):

Single bearings are attached to the sides of the bracket and double bearings to the middle portion of the bracket. Use 1/4" hex bolts and locknuts as needed. Install a flat washer on both sides of each bearing to insure proper operation of bearings and the assembly.

Install the longer bolts with bearings on the side of the bracket that has the two holes. Install these *before* installing the double bearing assemblies. See the figures below.

7. For the spacers on the long bolts, insert a 5/16" nut over each bolt. *These nuts are used as spacers only.*

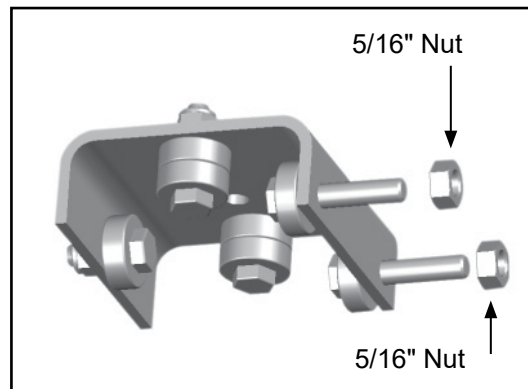

TWIST-OF-THE-WRIST ASSEMBLY (Continued)

- Slide the Twist-of-the-Wrist mounting plate over the long bolts and secure the plate with two lock nuts

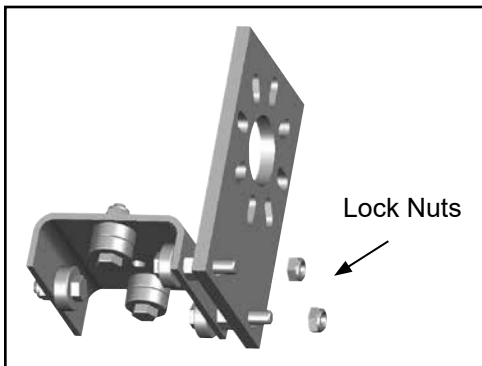

- Attach the Twist-of-the-Wrist gearbox to the mounting plate using hex head bolts.

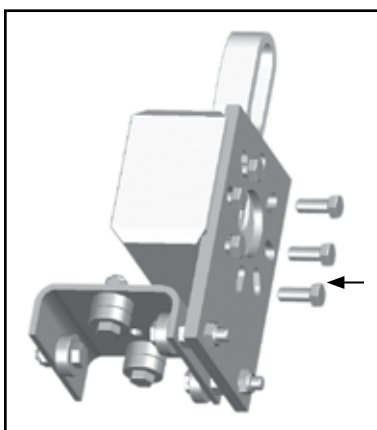

- Using a carriage bolt, attach the square shaft to a tubing adapter.



- Slide the square shaft through the Twist-of-the-Wrist gearbox.

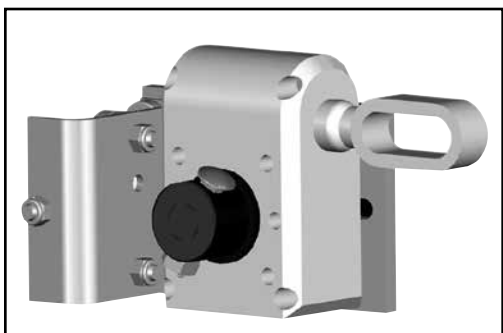

- Slide the Twist-of-the-Wrist assembly onto the aluminum channel from the ground end. (This is the free end of the channel.)

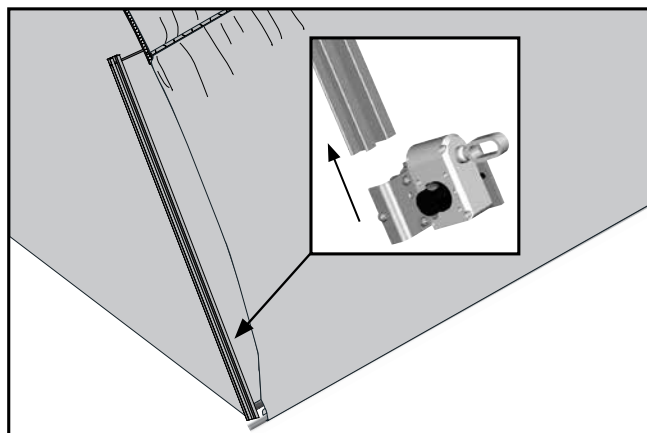

- Roll the cover conduit up to the Twist-of-the-Wrist assembly.

- Attach the rolled conduit to the square shaft of the assembly by inserting a carriage bolt through the hole in the conduit and tubing adapter. Tighten the nut.

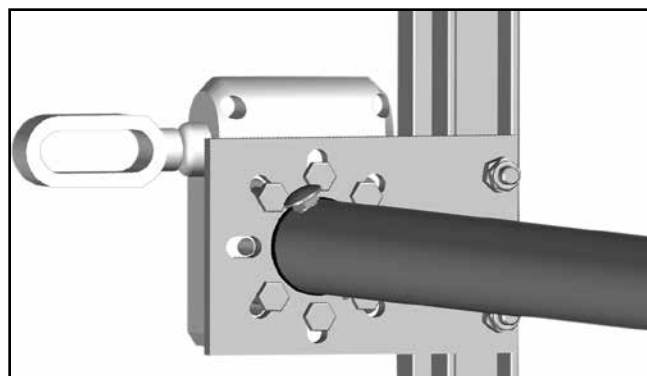

- Attach the crank handle to the Twist-of-the-Wrist assembly. (Cover is not shown in the above diagram.)

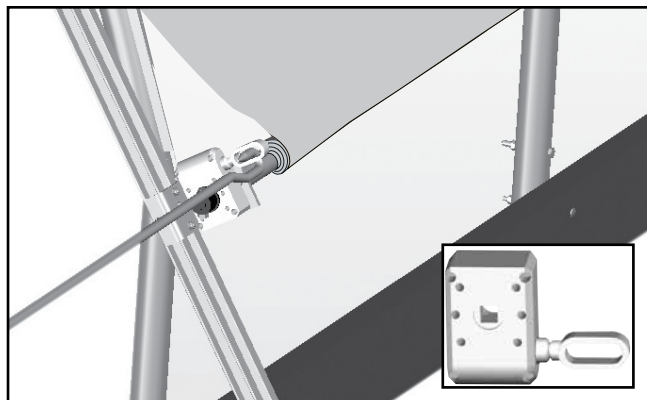

- Test the operation of the Twist-of-the-Wrist assembly.

NOTE: If the cover rolls in the desired direction, but you want to turn the crank in the opposite direction for the same result, unbolt, reposition the gearbox, and remount it *on the same side of the mounting bracket.*

CLEARSPAN™ ECONOMY MOO-TEL™

INSTALL ANTI-BILLOW ROPES

Gather the parts:

- 1/4" eyebolts and eye screws
- Anti-billow rope
- 1/4" nuts and washers

Install anti-billow rope in short sections along each side. **Do not install as a single length tied at each end.** Complete the following steps to install the ropes.

ATTENTION: The procedure that follows is applicable when the frame was constructed using wood boards under each rafter foot, or if baseboards were installed. If the shelter was constructed on concrete footings, a concrete slab, or on bare ground, alternative steps must be taken by the owner during the following procedure to anchor the lower ends of the anti-billow ropes. *Additional parts may be required and must be supplied by the customer.*

1. Using the Twist-of-the-Wrist assembly, roll up the sidewall so that it is a few inches above the ground.
2. Drill a 5/16" hole through the wood baseboard at the base of the end rafter where the Twist-of-the-Wrist assembly is located and install the first 1/4" eyebolt and 1/4" washer. *Do not drill through the rafter.*

ATTENTION: If no wood baseboard is present, drill the hole through the ground post at ground level and install the eye bolt and washer. Customer-supplied eye screws can also be used in the baseboard if desired.

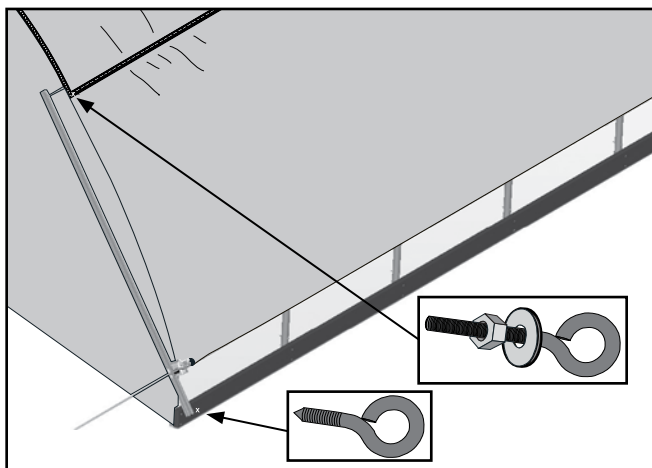

3. Move up the same end rafter and drill a 5/16" hole through the poly latch U-Channel and rafter leg, insert an eyebolt and washer through the hole, and secure the eyebolt with a nut.

NOTE: If the poly latch U-Channel was attached to a ribbon board (as suggested), the eyebolt can be mounted through the poly latch channel and ribbon board to the inside of the rafter.

ANTI-BILLOW ROPE INSTALLATION

TO PREVENT DAMAGE AND POSSIBLE INJURY, INSTALL THE ANTI-BILLOW ROPES IN SHORT LENGTHS ALONG EACH SIDE OF THE FRAME.

DO NOT INSTALL AS A SINGLE LENGTH TIED AT EACH END OF THE BUILDING. DOING SO WILL RESULT IN A LOOSE SIDE PANEL IF THE SINGLE ROPE BREAKS DURING STRONG WINDS.

4. Attach the remaining eyebolts and eye screws using the diagram below as a pattern guide.

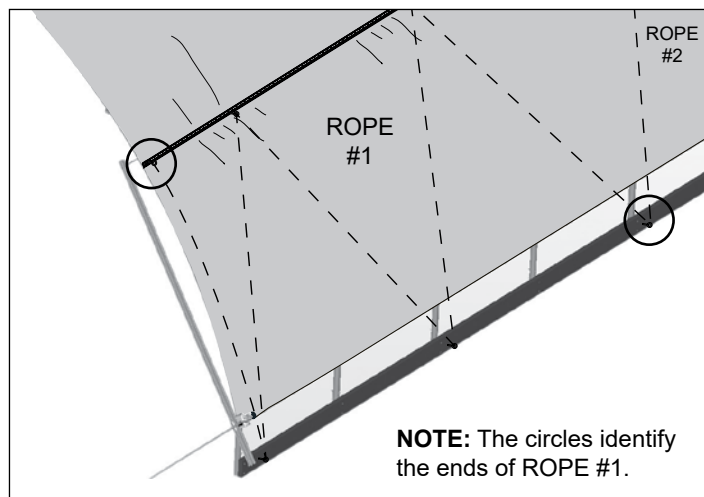

5. Once all eyebolts/eye screws are installed in the proper locations, install the anti-billow rope **in short lengths along each side**. Thread the free end of the rope through the end rafter eyebolts/eye screws and the eyebolts/eye screws at two to three interior rafters.
 6. Cut the rope and tie one end to the eyebolt/eye screw.
 7. Pull the rope tight and tie the remaining end to secure.
 8. Repeat the steps to install another section of anti-billow rope. Continue this pattern until all ropes are tied along one side and repeat the steps to install the anti-billow ropes for the remaining side.
- NOTE:** The number of individual ropes along any one side depends on the length of the building, rafter spacing, and the length of the rope sections.
9. Check the roll-up side operation.
 10. Read the shelter care and maintenance information that follows.

Space below is reserved for customer notes.

SHELTER CARE AND MAINTENANCE

Proper care and maintenance of the shelter is important. Check the following items periodically to properly maintain the shelter:

- Regularly check the main cover and panels (if equipped) to see that these remain tight and in proper repair.
- Check connections and all fasteners to verify that they remain tight.
- Do not climb or stand on the frame at anytime.
- Remove debris and objects that may accumulate on the cover. Use tools that will not damage the cover when removing debris.
- Remove snow to prevent excess accumulation. Use tools that will not damage the cover when removing snow.
- Check the contents of the shelter to verify that nothing is touching the cover or the side panels that could cause damage.
- Check the anchoring system to ensure that all components are tight and in good repair.
- If the shelter is moved, inspect all parts and connections before reassembling.
- For replacement or missing parts, call 1-800-245-9881 for assistance.

NOTE: With the exception of Truss Arch buildings, ClearSpan™ shelters and greenhouses *do not* have any tested loading criteria.

ClearSpan

QUICK START GUIDE

Economy Moo-Tel™

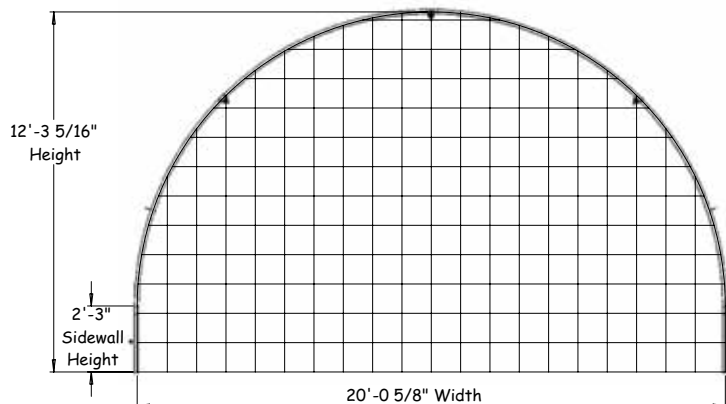

FRONT

Grid Represents 12" Squares

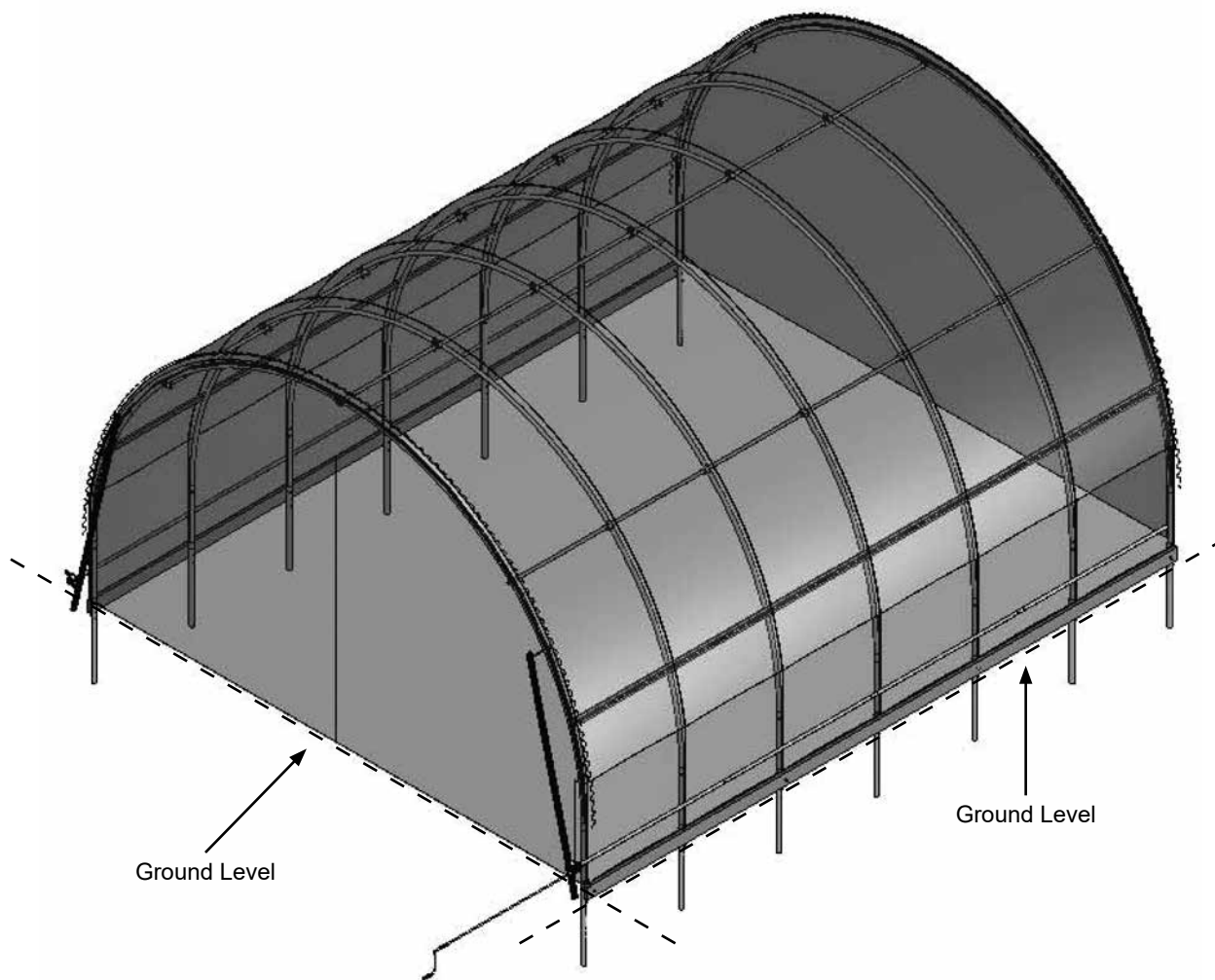
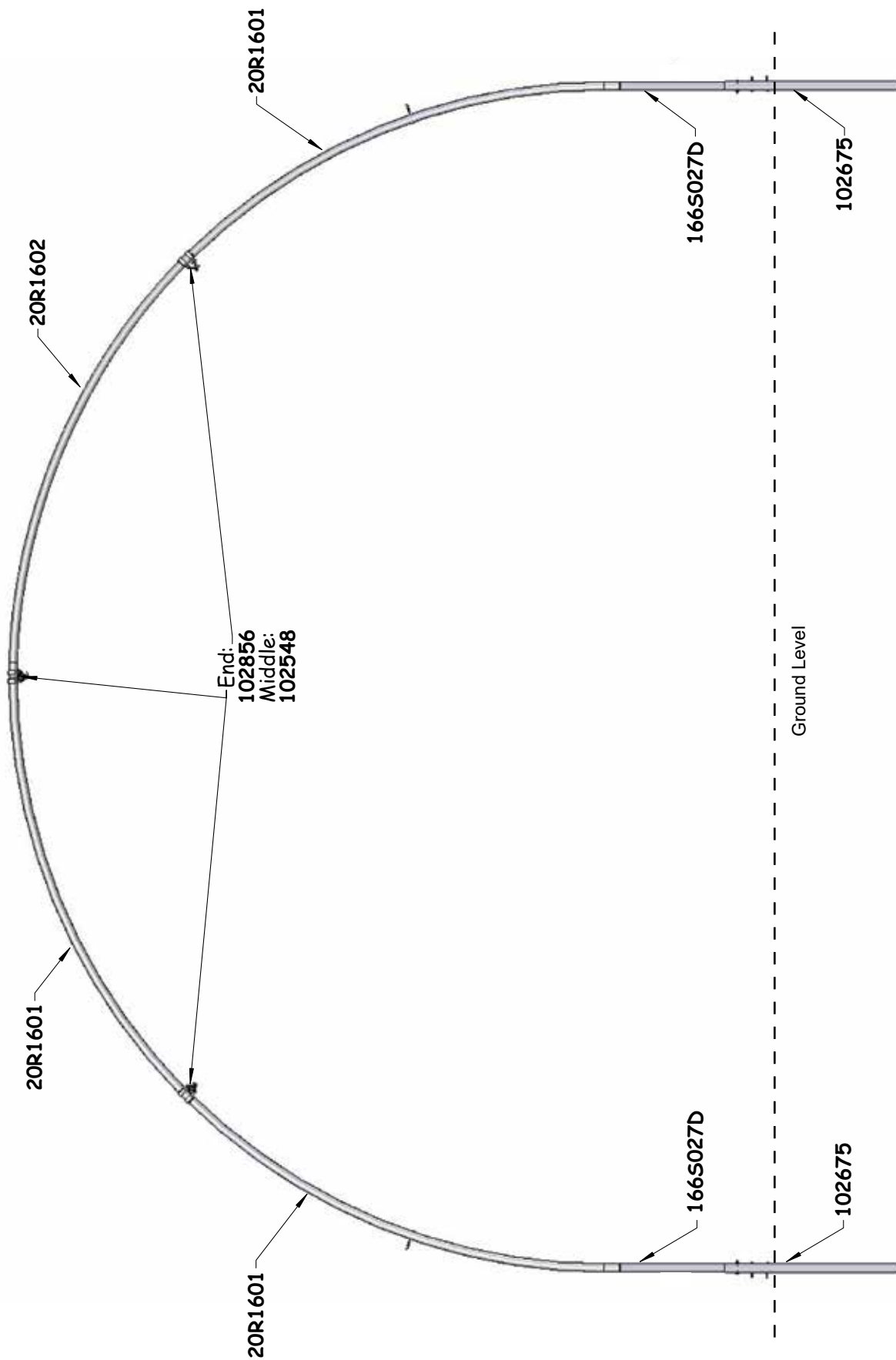

Photo may show a different but similar model. The optional end panels (additional purchase required) are shown. Actual building may differ. Side struts are not shown in the above diagram.

FRONT PROFILE



SIDE PROFILE - 107404

ATTENTION: Dashed lines show the location of the diagonal struts installed along each side of the frame at each end.

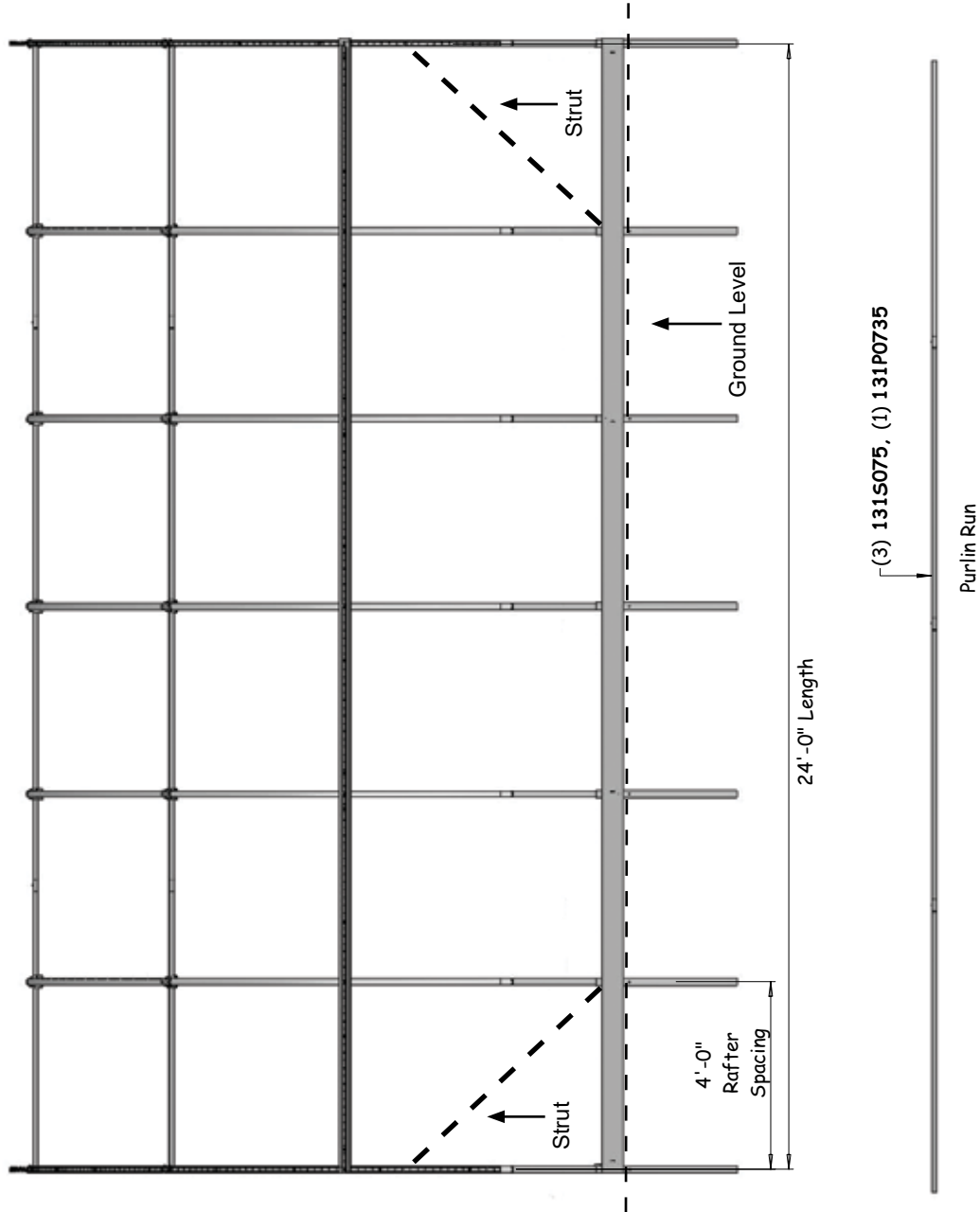

SIDE PROFILE - 107405

ATTENTION: Dashed lines show the location of the diagonal struts installed along each side of the frame at each end.

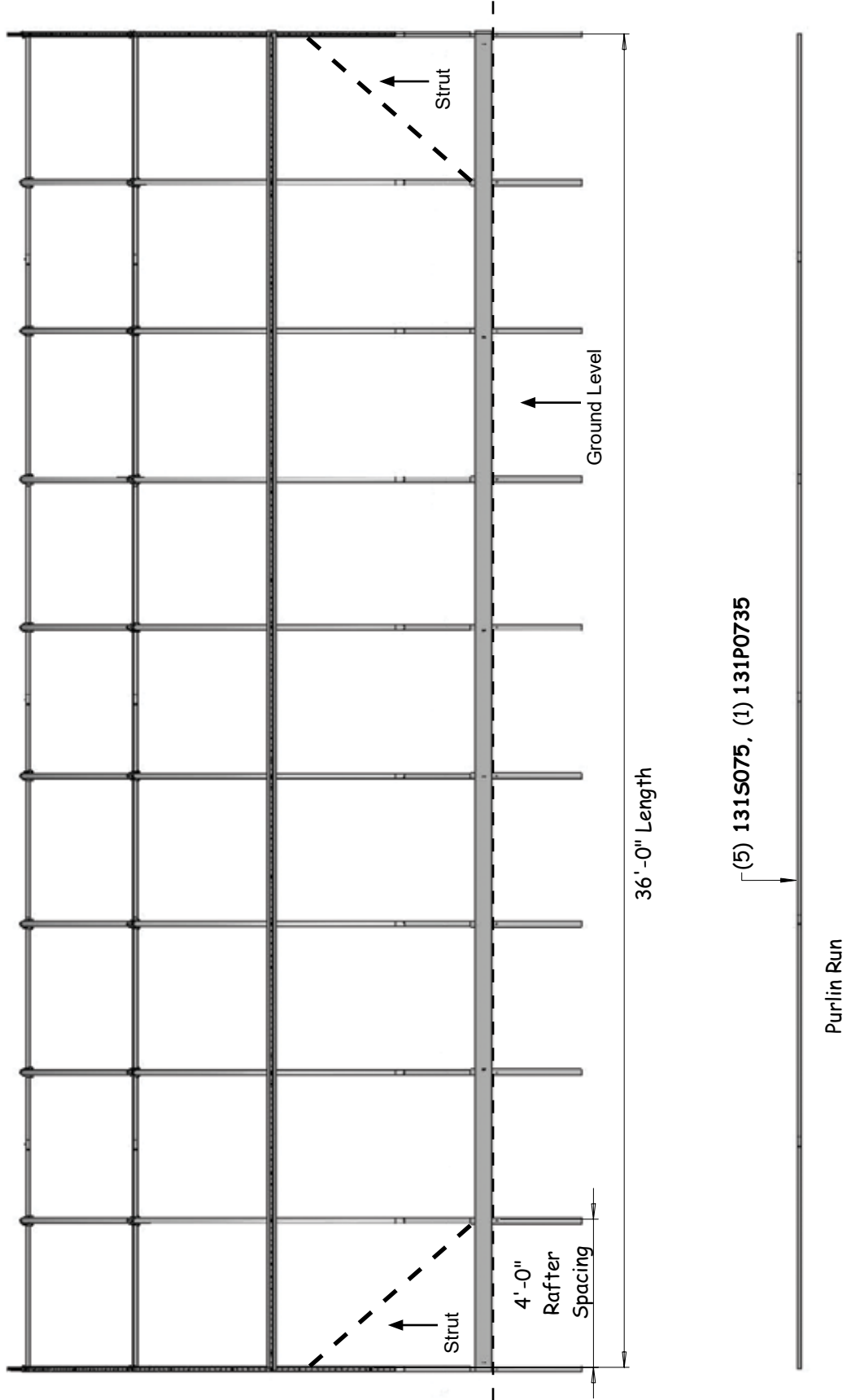

SIDE PROFILE - 107406

ATTENTION: Dashed lines show the location of the diagonal struts installed along each side of the frame at each end.

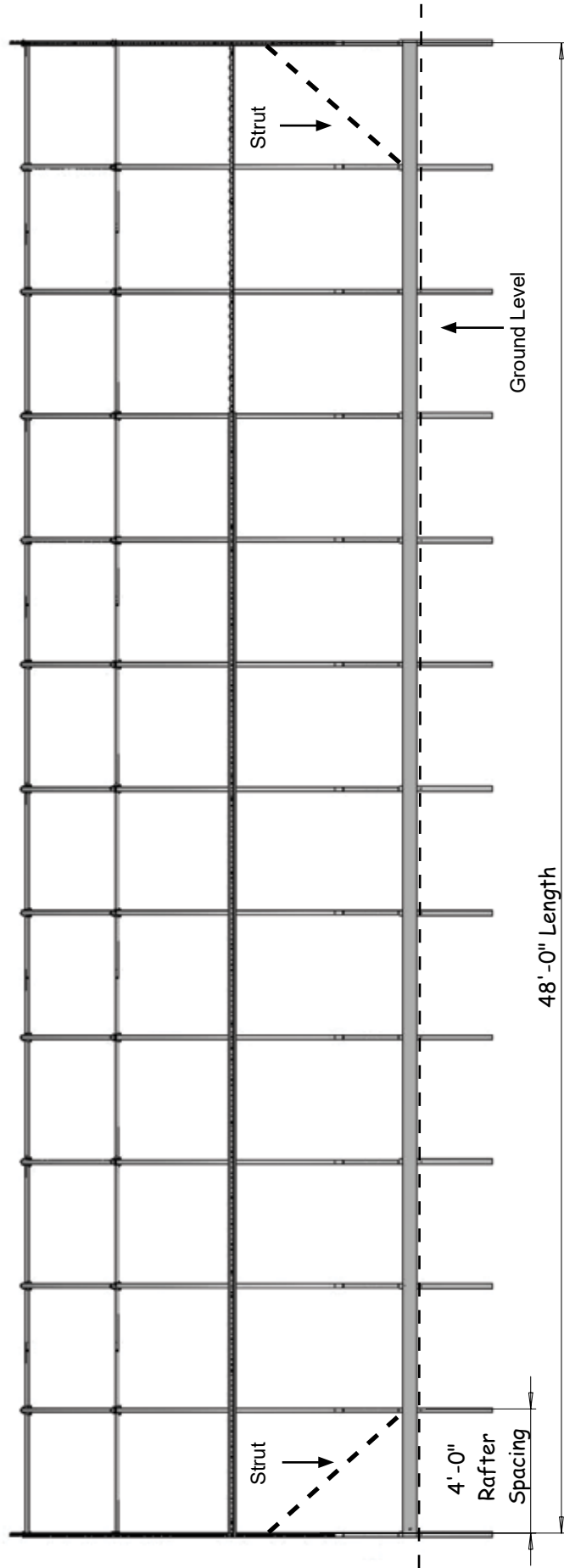

(7) 131S075, (1) 131P0735

Purlin Run

CONNECTIONS

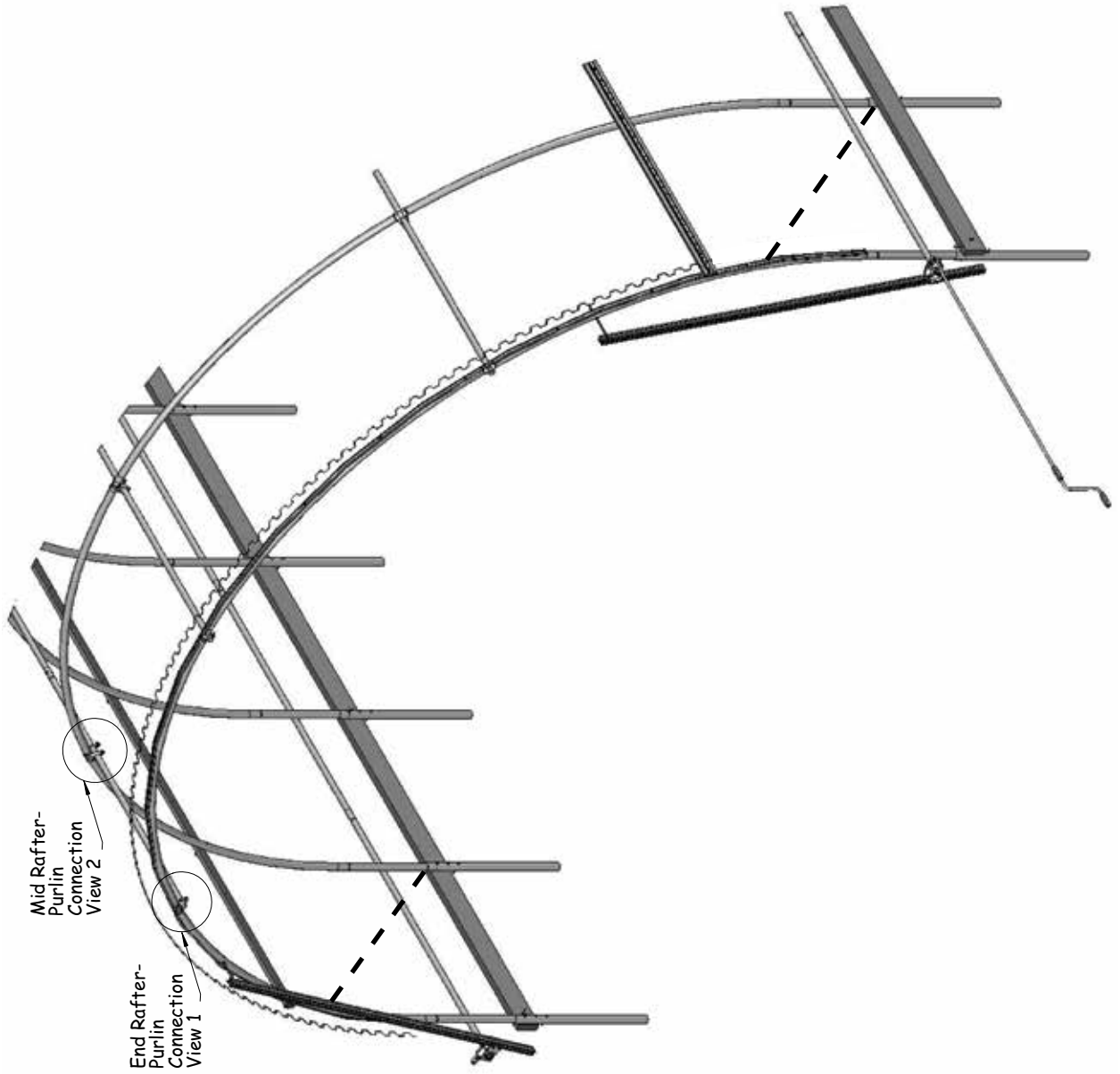

CONNECTION - DETAILS

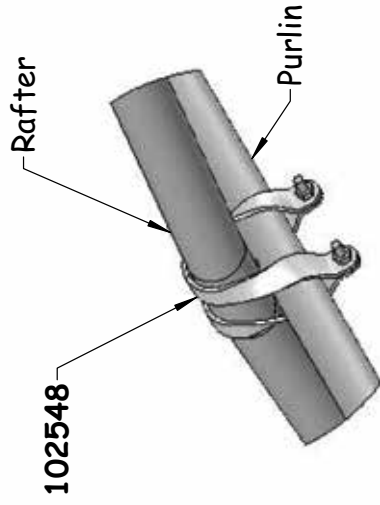

**View 2
Mid Rafter -
Purlin
Connection**

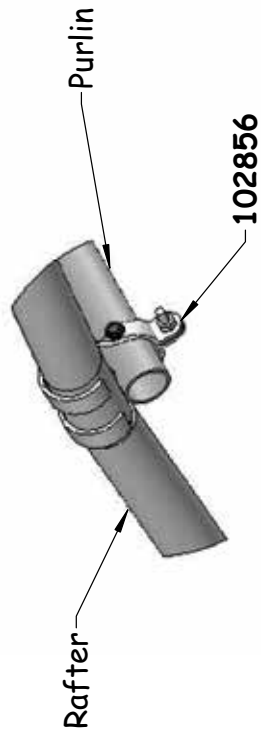

**View 1
End Rafter -
Purlin
Connection**



This page is reserved for customer notes.