



INSTALLATION AND OPERATION INSTRUCTIONS

OWNER / INSTALLER: For your safety this manual must be carefully and thoroughly read and understood before installing, operating or servicing this heater.

INFRARED RADIANT TUBE HEATER Single Stage Pull Through System (Negative Pressure)

Models:

SIS SERIES: (50, 75, 100, 125, 150, 175) – N5/L5

SIU SERIES: (50, 75, 100, 125, 150, 175) – N5/L5

!INSTALLER: This manual is the property of the owner. Please present this manual to the owner when you leave the job site.

▲WARNING: Improper installation, adjustment, alteration, service, or maintenance can cause property damage, injury or death. Read the installation, operation and maintenance instructions thoroughly before installing or servicing this equipment.

IF YOU SMELL GAS:

- ! **DO NOT** try to light any appliance.
- ! **DO NOT** touch any electrical switch; **DO NOT** use any telephone in your building.
- ! **IMMEDIATELY** call your gas supplier from a neighbor's telephone. Follow the gas supplier's instructions. If you cannot reach your gas supplier, call the fire department.

FOR YOUR SAFETY

DO NOT store or use gasoline or other flammable vapors and liquids in the vicinity of this or any other appliance.

!IMPORTANT: SAVE THIS MANUAL FOR FUTURE REFERENCE.

SUNSTAR HEATING PRODUCTS, INC.

Post Office Box 36271 (28236) • 306 West Tremont Avenue (28203) • Charlotte, North Carolina
Phone (704) 372-3486 • Fax (704) 332-5843 • www.sunstarheaters.com • email: info@sunstarheaters.com

TABLE OF CONTENTS

<u>SECTION</u>	<u>DESCRIPTION</u>	<u>PAGE</u>
1.0)	Safety	2
2.0)	Installer Responsibility	2
3.0)	General Information.....	2
4.0)	Minimum Clearances to Combustibles.....	4
5.0)	Specifications.....	5
6.0)	Packing List.....	5
6.1)	Accessory Packages	8
7.0)	Typical Layouts	10
8.0)	Dimensions – SIS Series.....	11
8.1)	Dimensions – SIU Series.....	12
8.2)	Heater Assembly / Joining of Tube Sections	13
9.0)	Typical Suspension Methods	15
10.0)	Assembly of Tube Sections.....	16
10.1)	Assembly of Extension Sections	17
10.2)	Adding Reflectors.....	18
10.3)	Adding Optional 90° Elbow (SIS Only).....	19
10.4)	Adding Optional Corner Reflector (SIS Only).....	20
10.5)	Adding 180° U-Bend (SIU Only)	20
10.6)	Adding Optional U-Bend Reflector (SIU Only).....	21
11.0)	Attaching Control Box Assembly.....	22
12.0)	Attaching Draft Inducer Assembly.....	23
13.0)	Multiple Hanging & Draft Inducer Positions	24
14.0)	Gas Connections and Regulations.....	25
15.0)	Instructions for Pressure Test Gauge Connection.....	27
16.0)	Electrical Connections	28
17.0)	Venting.....	32
18.0)	Air for Combustion	36
18.1)	Direct Outside Air for Combustion	36
19.0)	Lighting and Shutdown Instructions.....	38
20.0)	Sequence of Operation.....	38
21.0)	Control Component Location.....	39
22.0)	Cleaning and Annual Maintenance	40
23.0)	Troubleshooting Guide.....	41
24.0)	Replacing Parts	44
24.1)	Removing Spark Electrode	44
24.2)	Removing Main Burner and Gas Valve	45
24.3)	Air Switch Pressure Check.....	46
24.4)	Ignition System Checks.....	46
24.5)	Motor and Blower Wheel Check.....	47
25.0)	Installation Data	47
26.0)	Replacement Parts Guide.....	48
27.0)	Warnings Card	53

This heater complies with ANSI Z83.20 (current standard) and CSA 2.34. Copies of the National Fuel Gas Code (ANSI Z223.1-latest edition) are available from the CSA at 8501 East Pleasant Valley Road, Cleveland, Ohio 44131 or 55 Scarsdale Road, Don Mills, Ontario M3B 2R3. All NFPA codes are available from the National Fire Protection Association, Batterymarch Park, Quincy, Massachusetts 02269.

1.0) SAFETY

This heater is a self-contained infrared radiant tube heater. Safety information required during installation and operation of this heater is provided in this manual and the labels on the product. The installation, service and maintenance of this heater must be performed by a contractor qualified in the installation and service of gas fired heating equipment.

All personnel in contact with the heater must read and understand all safety information, instructions and labels before operation. The following symbols will be used in this manual to indicate important safety information.

WARNING

Warning instructions must be followed to prevent or avoid hazards which may cause serious injury, property damage or death.

CAUTION

Caution instructions must be followed to prevent incorrect operation or installation of the heater which may cause minor injury or property damage.

2.0) INSTALLER RESPONSIBILITY

The installer is responsible for the following:

- The heater and venting, as well as electrical and gas supplies must be installed in accordance with these installation instructions and any applicable codes and regulations.
- Every heater shall be located with respect to building construction and other equipment so as to permit access to the heater.
- Each installer must follow the clearances to combustible materials for the heaters.
- Install the heater so that the supports and hangers are correctly spaced in accordance with these instructions. The heater must be supported by materials having a working load limit of at least 115lbs.
- Supply the owner with a copy of these Installation and Operation Instructions.
- Where unvented heaters are used, gravity or mechanical means shall be provided to supply and exhaust at least 4 CFM per 1,000 Btu/hr input of installed heaters.
- Never use the heater as a support for a ladder or other access equipment. Do not hang anything from the heater.
- Supply all installation materials necessary that are not included with the heater.
- Check the nameplate to make sure that the burner is correct for the gas type in the building and the installation altitude.

3.0) GENERAL INFORMATION

This heater is a self-contained infrared radiant tube heater for use in locations where flammable gases or vapors are not generally present (as defined by OSHA acceptable limits) and is intended for the heating of **nonresidential** spaces.

INSTALLATION REQUIREMENTS

The installation must conform to local building codes or in the absence of local codes, with the National Fuel Gas Code ANSI Z223.1/NFPA54 or the Natural Gas and Propane Installation Code CSA B149.1. Heaters shall be installed by a licensed contractor or licensed installer. Clearances to combustibles as outlined in this manual should always be observed. In areas used for storage of combustible materials where they may be stacked below the heater, NFPA54 requires that the installer must post signs that will "specify the maximum permissible stacking height to maintain the required clearances from the heater to combustibles."

Every heater shall be located with respect to building construction and other equipment so as to permit access to the heater. Each installer shall use quality installation practices when locating the heater and must give consideration to clearances to combustible materials, vehicles parked below, lights, overhead doors, storage areas with stacked materials, sprinkler heads, gas and electrical lines and any other possible obstructions or hazards. Consideration also must be given to service accessibility.

The heater, when installed in aircraft hangars and public garages, must be installed in accordance with ANSI/NFPA 409-latest edition (Standard for Aircraft Hangars), ANSI/NFPA 88a-latest edition (Standard for Parking Structures), and ANSI/NFPA 88b-latest edition (Standard for Repair Garages) with the following clearances:

- a. At least 10 feet above the upper surfaces of wings or engine enclosures of the highest aircraft that may be housed in the hangar and at least 8 feet above the floor in shops, offices, and other sections of hangars communicating with aircraft storage or service areas.
- b. At least 8 feet above the floor in public garages. **▲WARNING:** Minimum clearances marked on the heater must be maintained from vehicles parked below the heater.

(FOR CANADA ONLY)

- a. Installation of this appliance is to be in accordance with latest edition of CSA B149.1 (Natural Gas and Propane Installation Code).
- b. For installation in public garages or aircraft hangars, the minimum clearances from the bottom of the infrared heater to the upper surface of the highest aircraft or vehicle shall be 50 percent greater than the certified minimum clearance, but the clearance shall not be less than 8 feet.

Although these heaters may be used in many applications other than space heating (e.g., process heating), SunStar will not recognize the warranty for any use other than space heating.

For indoor installation only. Not for use in residential dwellings.

This heater is for Indoor Installation and Covered Patio Installation only and can be used in either Vented or Unvented mode. The term Unvented actually means Indirect Vented. While the products of combustion are expelled into the building, national codes require ventilation in the building to dilute these products of combustion. This ventilation may be provided by gravity or mechanical means.

This heater is not an explosion proof heater. Where the possibility of exposure to volatile and low flash point materials exists, it could result in property damage or death. This heater must not be installed in a spray booth where the heater can operate during the spraying process. Consult your local fire marshal or insurance company.

SIS Series Only: Since straight tube heaters are always hotter at the control end than at the flue terminal end, always observe the minimum recommended mounting heights shown on the specification sheets in Section 5.0 of this manual. Use U-tube configuration instead of straight tubes for spot or area heating (e.g., where a single heater is utilized for space heating).

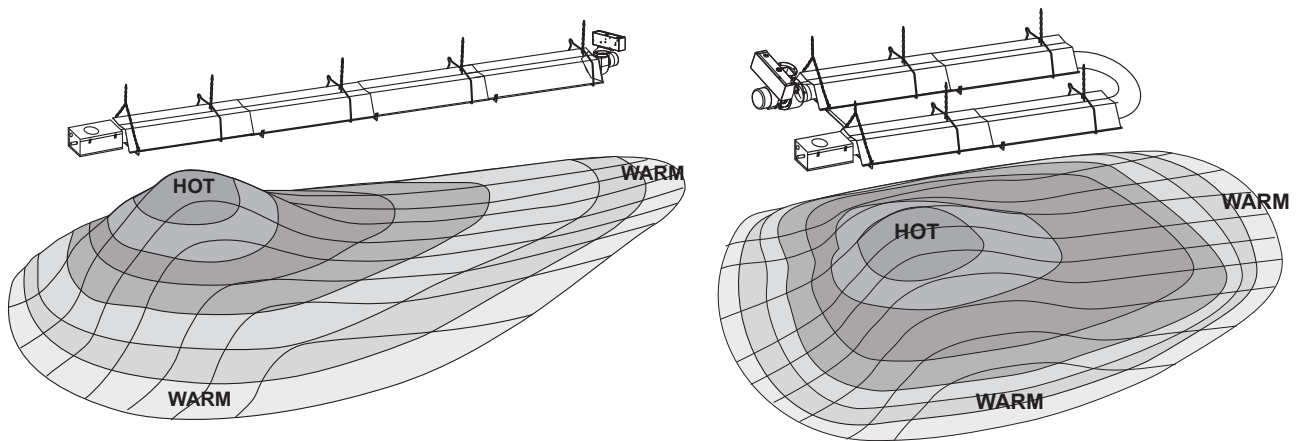

High Altitude:

Appliances are supplied as standard for altitudes of 0 to 2,000 feet (0-610 m). High-altitude ratings are obtained by a change in the orifice size. When ordered for high altitude installations, burners are supplied by the factory ready for high altitude installation. Check the nameplate for altitude before proceeding with the installation. In Canada the adjustment for altitude is made in accordance with Standard CGA 2.17, Gas-Fired Appliances for Use at High Altitudes.

4.0) MINIMUM CLEARANCES TO COMBUSTIBLES

⚠ WARNING		
		FIRE AND EXPLOSION HAZARD Combustible material must be located outside the clearance dimensions listed. Failure to do so may result in death, serious injury or property damage.

Install the warnings card (ordered separately) and complete the blank spaces using the clearances from combustibles table below. See Section 27 for a printed copy of the warnings card.

Minimum clearances to combustibles shall be measured from the outer surfaces as shown in the following diagram:

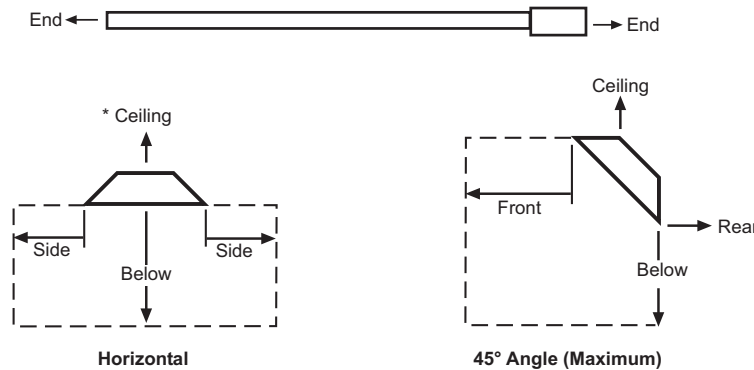

MINIMUM CLEARANCES TO COMBUSTIBLES						
Model No.	Mounted Horizontally				Angle Mounted at 45°	
	Sides	Ceiling*	Below	Ends	45° Front	45° Rear
SIS/SIU 50	24"	6"	40"	15"	40"	12"
SIS/SIU 75	24"	6"	60"	52"	52"	12"
SIS/SIU 100	28"	6"	76" **	15"	60"	12"
SIS/SIU 125	32"	6"	82" **	20"	66"	12"
SIS/SIU 150	36"	6"	87" **	20"	70"	12"
SIS/SIU 175	42"	6"	93" **	20"	77"	12"

* When used indirect vented, minimum clearance for CEILING must be: 12" for SIS/SIU 50-75 and 18" for SIS/SIU 100-175. If optional corner and U-bend reflectors are not used, the clearance must be 18".

** Maximum clearance below reduces by 50% once you are 25 ft. downstream from the burner box.

⚠ WARNING: Certain materials or objects, when stored under the heater, will be subjected to radiant heat and could be seriously damaged. Observe the Minimum Clearances to Combustibles listed in the manual and on the heater at all times.

NOTE:

1. The clearances specified above must be maintained to combustibles and other materials that may be damaged by temperatures 90°F above ambient temperature. Clearances to combustibles are posted on the control box. In areas used for storage of combustible materials where they may be stacked below the heater, NFPA54 requires that the installer must post signs that will "specify the maximum permissible stacking height to maintain the required clearances from the heater to combustibles." SunStar recommends posting these signs adjacent to the heater thermostat or other suitable location that will provide enhanced visibility.

2. The stated clearance to combustibles represents a surface temperature of 90 °F (32 °C) above room temperature. Building materials with a low heat tolerance (such as plastics, vinyl siding, canvas, tri-ply, etc.) may be subject to degradation at lower temperatures. It is the installer's responsibility to assure that adjacent materials are protected from degradation.

5.0) SPECIFICATIONS

Model No.	Btu/hr Input	Flue Restrictor Plate I.D. & Part #		Orifice Size				Minimum * Mounting Height	
				Natural Gas		Propane Gas		@ Horizontal	@ 45° Angle
SIS/SIU 50	50,000	1-1/8"	#42741030	3.3mm	(0.130)	#46	(0.081)	11 ft.	10 ft.
SIS/SIU 75	75,000	1-7/16"	#42741010	#20	(0.161)	#39	(0.099)	13 ft.	12 ft.
SIS/SIU 100	100,000	1-5/8"	#42741060	#14	(0.182)	#33	(0.113)	13 ft.	12 ft.
SIS/SIU 125	125,000	1-7/8"	#42741080	#5	(0.206)	#30	(0.129)	14 ft.	13 ft.
SIS/SIU 150	150,000	2-1/32"	#42741090	5.7mm	(0.224)	#28	(0.140)	15 ft.	14 ft.
SIS/SIU 175	175,000	2-1/4"	#42741100	"C"	(0.242)	3.8mm	(0.150)	15 ft.	14 ft.

* MOUNT HEATERS AS HIGH AS POSSIBLE. Minimums are shown as a guideline for human comfort and uniform energy distribution for complete building heating applications. Consult your SunStar representative for the particulars of your installation requirements.

Type Gas	Gas Pipe Connection ¹	Tube Diameter	Flue Connection ²	Fresh Air Connection	Electrical Supply	Current Rating
Natural or Propane	1/2" MPT (Male)	4"	4" Round	6" Round	120 Volt, 60Hz, 1 Phase	2.6 Amp

Fuse Rating:	Ignition System (direct spark):
In-line: 2 Amp 250V (for 24V Circuit)	30 second pre-purge period

6.0) PACKING LIST

A. SIS/SIU Control/Draft Inducer Package

Part Description	QTY
Control Box Assembly	1
Draft Inducer & Junction Box Assembly	1
Flue Restrictor Plate (See Section 5.0) for plate I.D. and part no.)	1
4" Starting Collar (#40504020)	1
Control Fastener Kit (#42907110)	1
Containing: #8-32 Screws & Nuts (#02166010 & #02127030)	2
1/4 - 20 Locknuts (#02167010)	6
Tube Flange Gasket (#42921000)	2
Draft Inducer Flange (#44015251)	1
Installation & Operation Instructions (#43343310)	1
Gas connector, 5/8" OD x 36" (#30302360)	1

CONTROL/DRAFT INDUCER PACKAGE NUMBERS

NATURAL GAS		PROPANE GAS	
MODEL NO.	PART NO.	MODEL NO.	PART NO.
SIS/U 50-N5	#43502030	SIS/U 50-L5	#43502040
SIS/U 75-N5	#43502070	SIS/U 75-L5	#43502080
SIS/U 100-N5	#43503050	SIS/U 100-L5	#43502060
SIS/U 125-N5	#43503110	SIS/U 125-L5	#43503120
SIS/U 150-N5	#43503170	SIS/U 150-L5	#43503180
SIS/U 175-N5	#43503210	SIS/U 175-L5	#43503220

B. SIS Body Package Descriptions

(Package Part Number is indicated on the outside of each corresponding carton.)

System Lengths		15 Ft. System	20 Ft. System	30 Ft. System	40 Ft. System	50 Ft. System
SIS 50-175 Body Packages – Aluminized/Hot Rolled		15 Ft. Pkg. 44134000	20 Ft. Pkg. 44135000	30 Ft. Pkg. 44136000	40 Ft. Pkg. 44137000	50 Ft. Pkg. 44138000
Part #	Each Body Package Includes:	Qty.	Qty.	Qty.	Qty.	Qty.
42912180	10 Ft. Tube with 12 Hole Flange (Aluminized)	1	1	1	1	1
41932101	10 Ft. Tube less Flanges (Hot Rolled)	-	1	2	3	4
41932051	5 Ft. Tube less Flanges (Hot Rolled)	1	-	-	-	-
43319100	Reflector, 9' 11½"	1	2	3	4	5
43319050	Reflector, 4' 11½"	1	-	-	-	-
30462980	Tube Coupling	1	1	2	3	4
43318000	Tube Hanger/Support Bracket, 13"	2	2	3	4	5
43980010	Wire Hanger	2	2	3	4	5

Body Fastener Kit (included in body packages)		42907190	42907190	42907200	42907210	42907220
42873000	U-Bolt	2	2	3	4	5
02127110	Hex Nut, 5/16-18	5	5	6	8	10
02189020	HWHSM Screw, #10-16 x ½" TEKS	8	8	10	14	18

C. SIU Body Package Descriptions

(Package Part Number is indicated on the outside of each corresponding carton.)

System Lengths		20 Ft. System	30 Ft. System	40 Ft. System	50 Ft. System
SIU 50-175 Body Packages – Aluminized/Hot Rolled		20 Ft. Pkg. 44135000	30 Ft. Pkg. 44136010	40 Ft. Pkg. 44137000	50 Ft. Pkg. 44138010
Part #	Each Body Package Includes:	Qty.	Qty.	Qty.	Qty.
42912180	10 Ft. Tube with 12 Hole Flange (Aluminized)	1	1	1	1
41932101	10 Ft. Tube less Flanges (Hot Rolled)	1	1	3	3
41932051	5 Ft. Tube less Flanges (Hot Rolled)	-	2	-	2
43319100	Reflector, 9' 11½"	2	2	4	4
43319050	Reflector, 4' 11½"	-	2	-	2
30462980	Tube Coupling	1	3	3	5
43318000	Tube Hanger/Support Bracket, 13"	2	4	4	6
43980010	Wire Hanger	2	4	4	6

Body Fastener Kit (included in body packages)		42907190	42907200	42907210	42907220
42873000	U-Bolt	2	4	4	5
02127110	Hex Nut, 5/16-18	5	8	8	10
02189020	HWHSM Screw, #10-16 x ½" TEKS	8	14	14	18

U-Bend package		43208020	43208020	43208020	43208020
42913020	U-Bend	1	1	1	1
43318500	31" Tube Support/Hanger Bracket	1	1	1	1
30462980	Tube Coupling	1	1	1	1
02189020	HWHSM Screw, #10-16 x ½" TEKS	2	2	2	2

D. "TOUGH GUY" SIS Body Package Descriptions

(Package Part Number is indicated on the outside of each corresponding carton.)

System Lengths		15 Ft. System	20 Ft. System	30 Ft. System	40 Ft. System	50 Ft. System
SIS 50-175 Body Packages – Aluminized		15 Ft. Pkg. 44134010	20 Ft. Pkg. 44135020	30 Ft. Pkg. 44136020	40 Ft. Pkg. 44137040	50 Ft. Pkg. 44138060
Part #	Each Body Package Includes:	Qty.	Qty.	Qty.	Qty.	Qty.
42912180	10 Ft. Tube with 12 Hole Flange (Aluminized)	1	1	1	1	1
41932100	10 Ft. Tube less Flanges (Aluminized)	-	1	2	3	4
41932050	5 Ft. Tube less Flanges (Aluminized)	1	-	-	-	-
43319100	Reflector, 9' 11½"	1	2	3	4	5
43319050	Reflector, 4' 11½"	1	-	-	-	-
30462980	Tube Coupling	1	1	2	3	4
43318000	Tube Hanger/Support Bracket, 13"	2	2	3	4	5
43980010	Wire Hanger	2	2	3	4	5

Body Fastener Kit (included in body packages)		42907190	42907190	42907200	42907210	42907220
42873000	U-Bolt	2	2	3	4	5
02127110	Hex Nut, 5/16-18	5	5	6	8	10
02189020	HWHSM Screw, #10-16 x ½" TEKS	8	8	10	14	18

E. "TOUGH GUY" SIU Body Package Descriptions

(Package Part Number is indicated on the outside of each corresponding carton.)

System Lengths		20 Ft. System	30 Ft. System	40 Ft. System	50 Ft. System
SIU 50-175 Body Packages – Aluminized		20 Ft. Pkg. 44135020	30 Ft. Pkg. 44136030	40 Ft. Pkg. 44137040	50 Ft. Pkg. 44138070
Part #	Each Body Package Includes:	Qty.	Qty.	Qty.	Qty.
42912180	10 Ft. Tube with 12 Hole Flange (Aluminized)	1	1	1	1
41932100	10 Ft. Tube less Flanges (Aluminized)	1	1	3	3
41932050	5 Ft. Tube less Flanges (Aluminized)	-	2	-	2
43319100	Reflector, 9' 11½"	2	2	4	4
43319050	Reflector, 4' 11½"	-	2	-	2
30462980	Tube Coupling	1	3	3	5
43318000	Tube Hanger/Support Bracket, 13"	2	4	4	6
43980010	Wire Hanger	2	4	4	6

Body Fastener Kit (included in body packages)		42907190	42907200	42907210	42907220
42873000	U-Bolt	2	4	4	5
02127110	Hex Nut, 5/16-18	5	8	8	10
02189020	HWHSM Screw, #10-16 x ½" TEKS	8	14	14	18

U-Bend package		43208020	43208020	43208020	43208020
42913020	U-Bend	1	1	1	1
43318500	31" Tube Support/Hanger Bracket	1	1	1	1
30462980	Tube Coupling	1	1	1	1
02189020	HWHSM Screw, #10-16 x ½" TEKS	2	2	2	2

6.1) ACCESSORY PACKAGES

A. End Reflector Accessory Package, Part #43341010

(1 pkg. per SIS Series or 2 pkgs. per SIU Series)

Contains:

End Reflector, #43320000.....QTY-2
Speed Clips, #02266010.....QTY-4

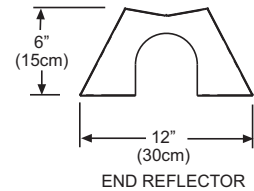

B. Elbow Accessory Package, Part #43208010

(Option for SIS Series Only)

Contains:

Elbow, #43175000.....QTY-1
#10-16 x 1/2 Self-Drilling Screws, #02189020.....QTY-2
Tube Coupling, #30462980.....QTY-1

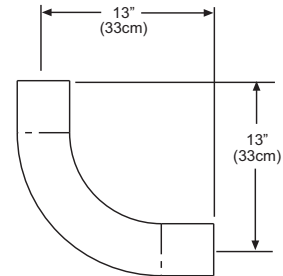

C. Corner Reflector Accessory Package, Part #43342000

(Option for SIS Series Only)

Contains:

Corner Reflector Assembly, #43345000.....QTY-1
Speed Clips, #02266010.....QTY-4

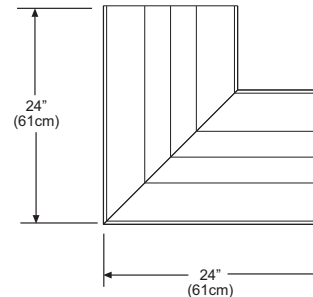

D. U-Bend Package, Part #43208020

(Option for SIU Series Only)

Contains:

U-Bend, #42913020.....QTY-1
#10-16 x 1/2 Self-Drilling Screws, #02189020.....QTY-2
Tube Coupling, #30462980.....QTY-1
31" Tube Support/Hanger Bracket, #43318500.....QTY-1

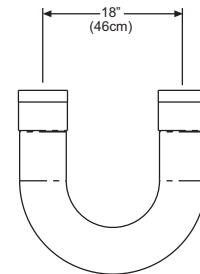

E. U-Bend Reflector Package, Part #43488000

(Option for SIU Series Only)

Contains:

U-Bend Reflector, #43490000.....QTY-1
U-Bend End Reflector, #43490050.....QTY-1
Speed Clips, #02266010.....QTY-11
#10-16 x 1/2 Self-Drilling Screws, #02189020.....QTY-4
Installation Form, #43489000.....QTY-1

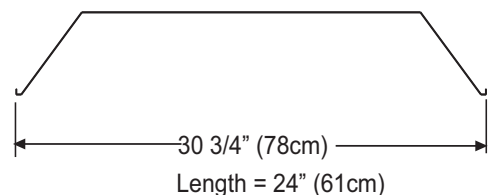

F. 31" Hanger/Tube Support, Part #43318500
(Option for Angle Mounting of SIU Series)

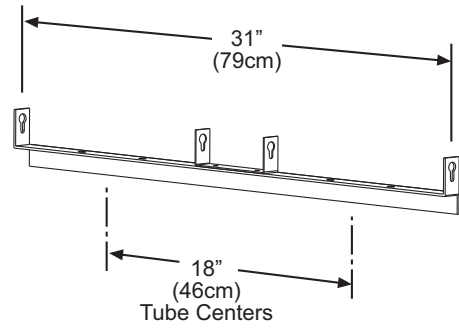

G. Exhaust Hood Package, Part #42924000

Contains:
Exhaust Hood Assembly, #42925540.....QTY-1
#8-18 x 1/2 Self-Drilling Screws, #02189030.....QTY-2

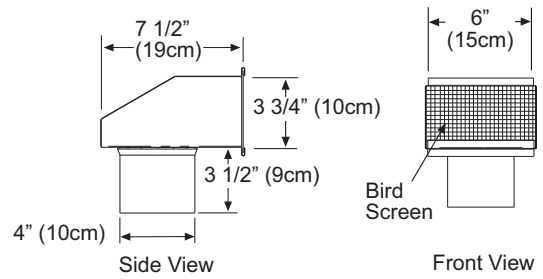

7.0) TYPICAL LAYOUTS

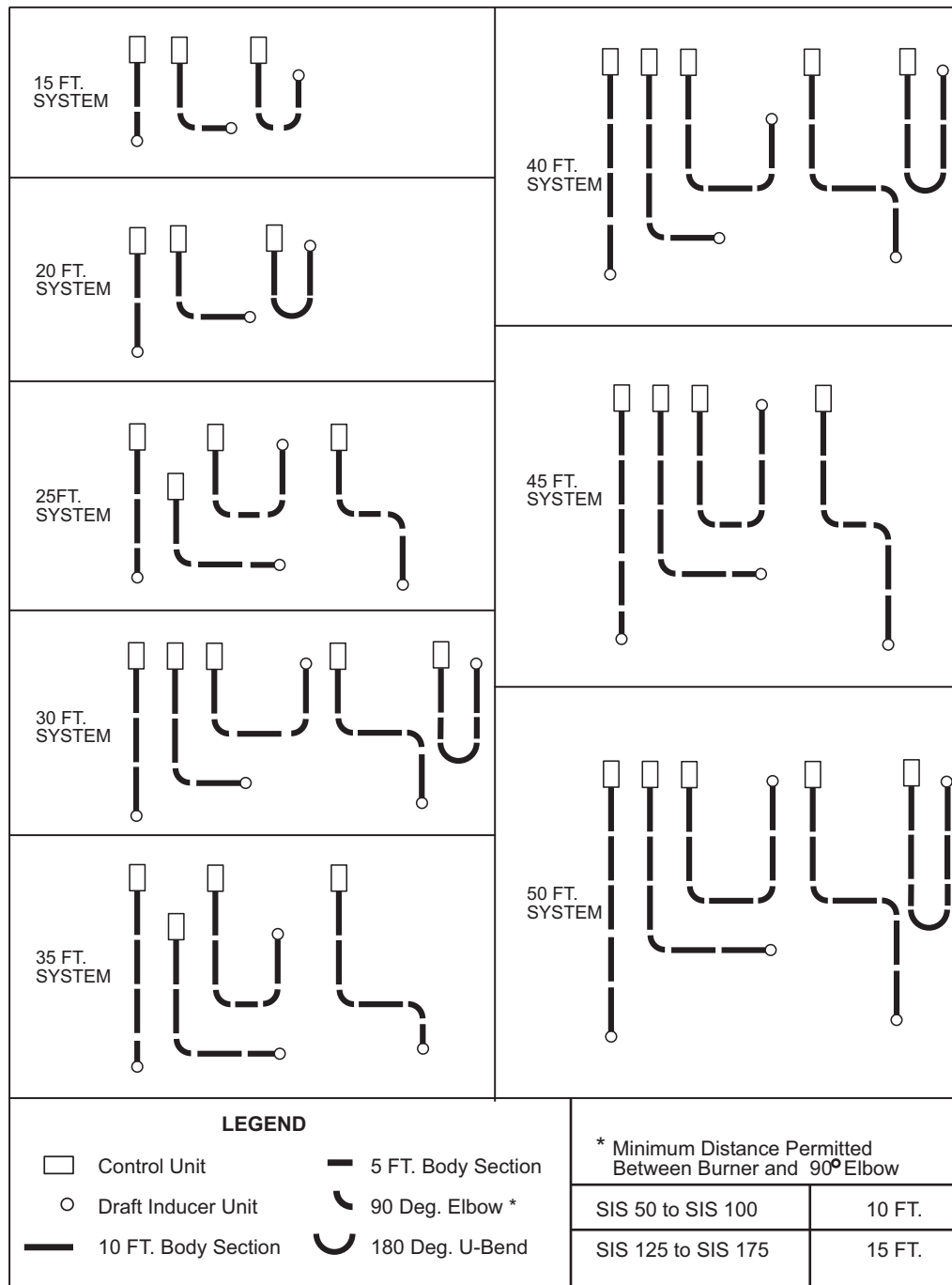

NOTES:

1. In all configurations, the control unit must be connected directly to the 24-hole flange of the 10 ft. aluminized steel start/end body section.
2. Joining of two 90° elbows directly together to form a "Z" shape **IS NOT** permitted.
3. Any configuration of components not shown in the illustrations may be used except as noted in 1 and 2 above.

MODEL	EMITTER LENGTH		MODEL	EMITTER LENGTH	
	Min.	Max.		Min.	Max.
SIS 50	15 Ft.	30 Ft.	SIU 50	20 Ft.	30 Ft.
SIS 75	20 Ft.	30 Ft.	SIU 75	20 Ft.	30 Ft.
SIS 100	30 Ft.	40 Ft.	SIU 100	30 Ft.	40 Ft.
SIS 125	30 Ft.	50 Ft.	SIU 125	30 Ft.	50 Ft.
SIS 150	40 Ft.	50 Ft.	SIU 150	40 Ft.	50 Ft.
SIS 175	40 Ft.	50 Ft.	SIU 175	40 Ft.	50 Ft.

8.0) DIMENSIONS - SIS SERIES

Typical Dimensions Up to 50 Ft. Shown.

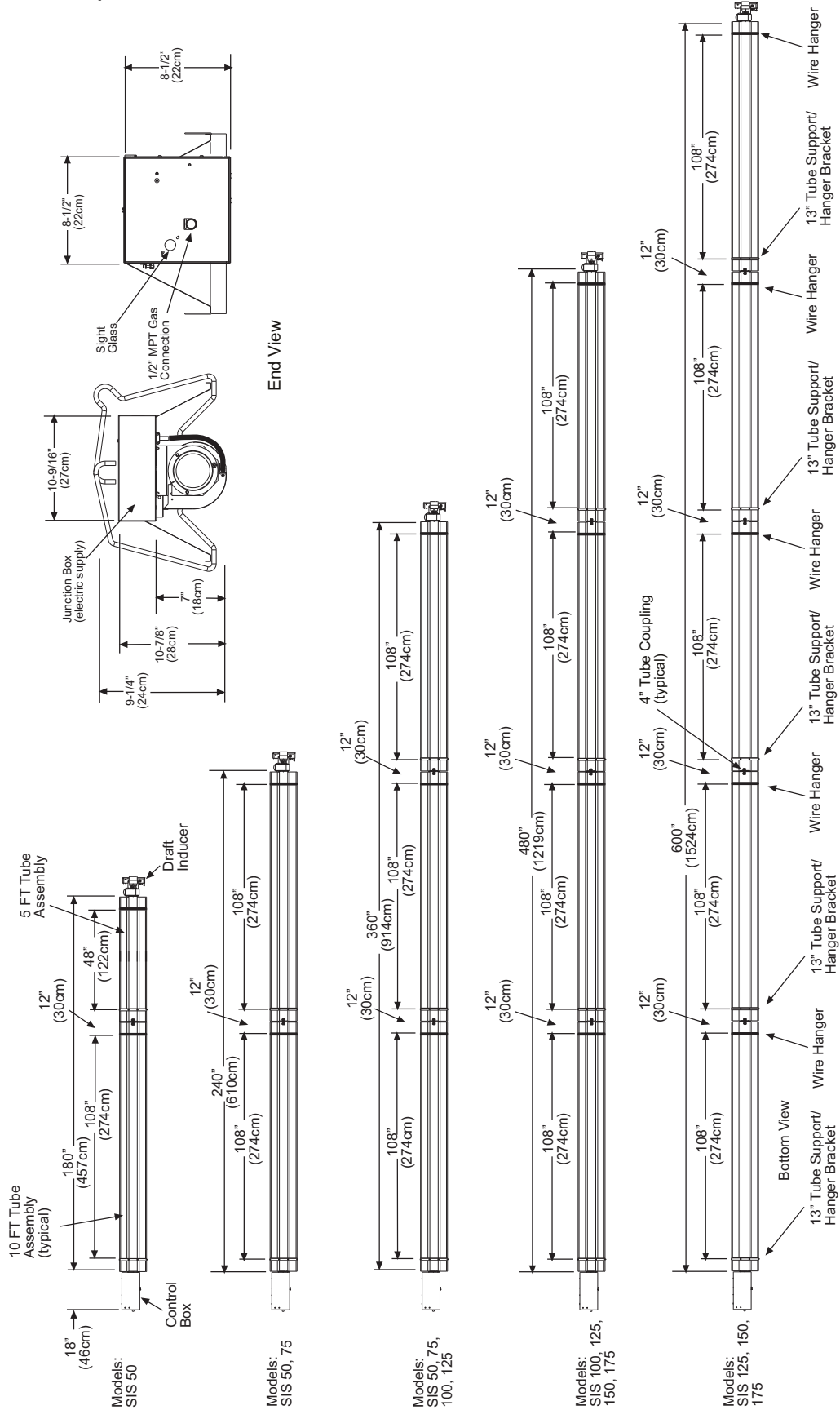

8.1) DIMENSIONS - SIU SERIES

Typical Dimensions Up to 50 Ft. Shown.

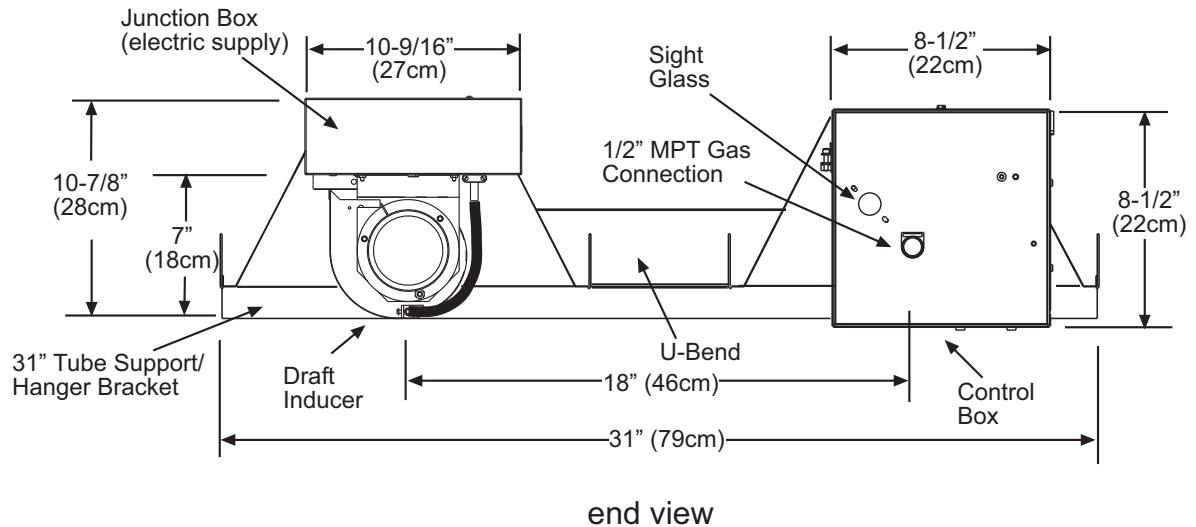
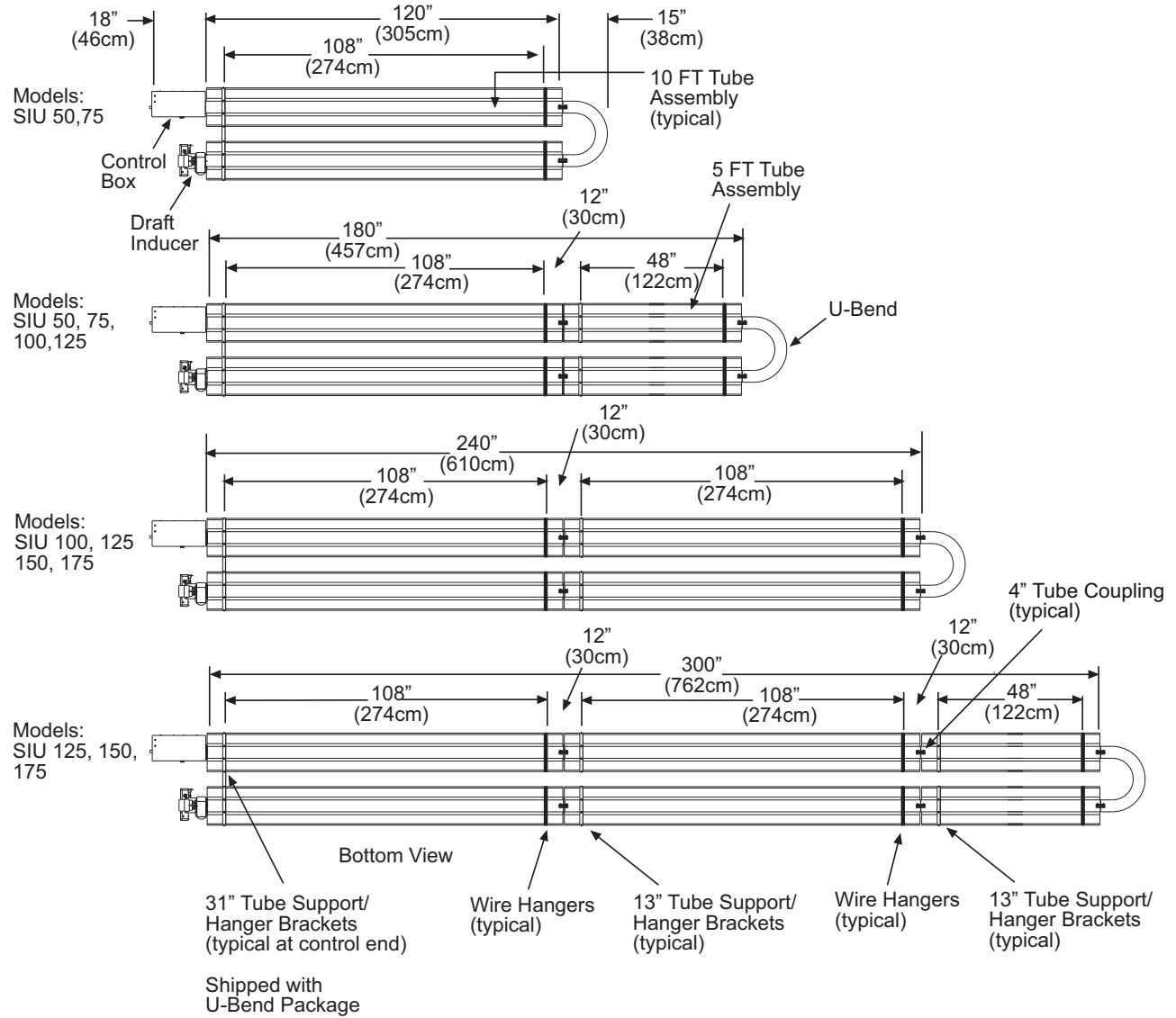

8.2) HEATER ASSEMBLY / JOINING OF TUBE SECTIONS

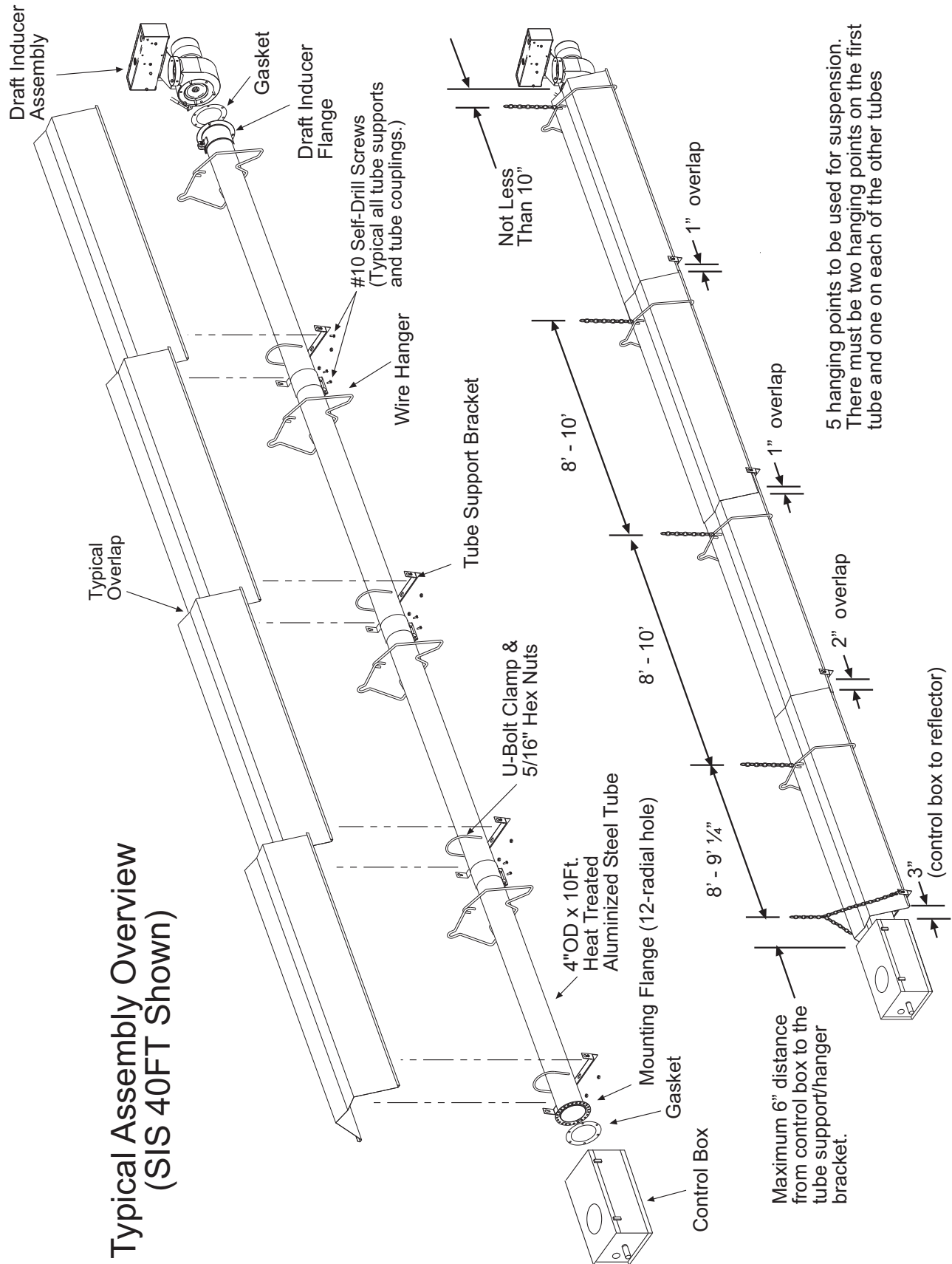

Typical Assembly Overview (SIU 40FT Shown)

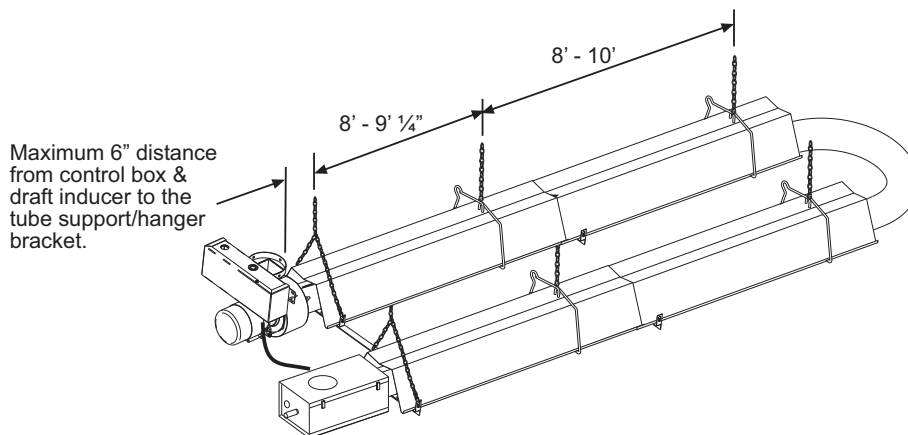
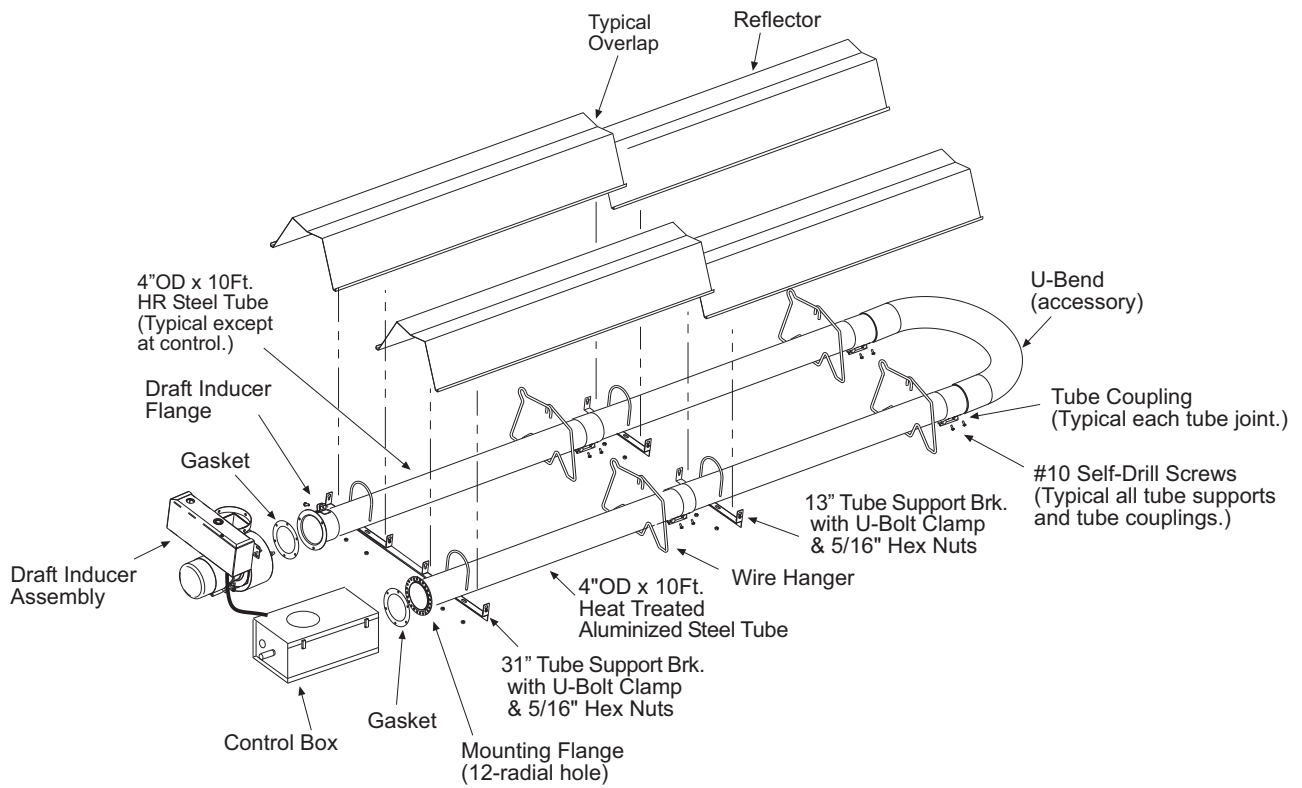

6 hanging points to be used for suspension. There must be two hanging points on the first tube and one on each of the other tubes

9.0) TYPICAL SUSPENSION METHODS

⚠ WARNING	
	<p>SUSPENSION HAZARD</p> <p>Burner must be secured to the mounting flange with nuts.</p> <p>All materials used to suspend the heater must have a minimum working load of 115 lbs.</p> <p>All "S" Hooks must be crimped closed.</p> <p>Never use the heater to support a ladder or other access equipment.</p> <p>Failure to do so may result in death, serious injury or property damage.</p>

Various means of suspending the heater can be used. See the following drawings for typical examples.

1. Use only noncombustible materials for suspending hangers and brackets.
2. A minimum No. 2 chain with a working load limit of 115 lbs. is required.
3. Turnbuckles can be used with chains to allow leveling of the heater. All "S" hooks and eye bolts must be manually crimped closed by the installer.
4. When using rigid means for heater suspension (rod, flat bar, etc.) provide sufficient lengths or swing joints to compensate for expansion. See Figures b and c.
5. Heaters subject to vibration must be provided with vibration isolating hangers.
6. Heaters must not be supported by gas or electric supply lines and must be suspended from a permanent structure with adequate load capacity.

SunStar recommends that the body sections be suspended using chains with turnbuckles. This will allow slight adjustments after assembly and heater expansion/ contraction during operation.

If a "trapeze" method is used for tube support/hanger brackets (shown below), the minimum chain length for the two connecting chains is 36" to minimize any vibration that might be generated by the draft inducer assembly. If these chains must be less than 36", then do not use the trapeze method and, instead, use individual chains on each tube support/hanger bracket.

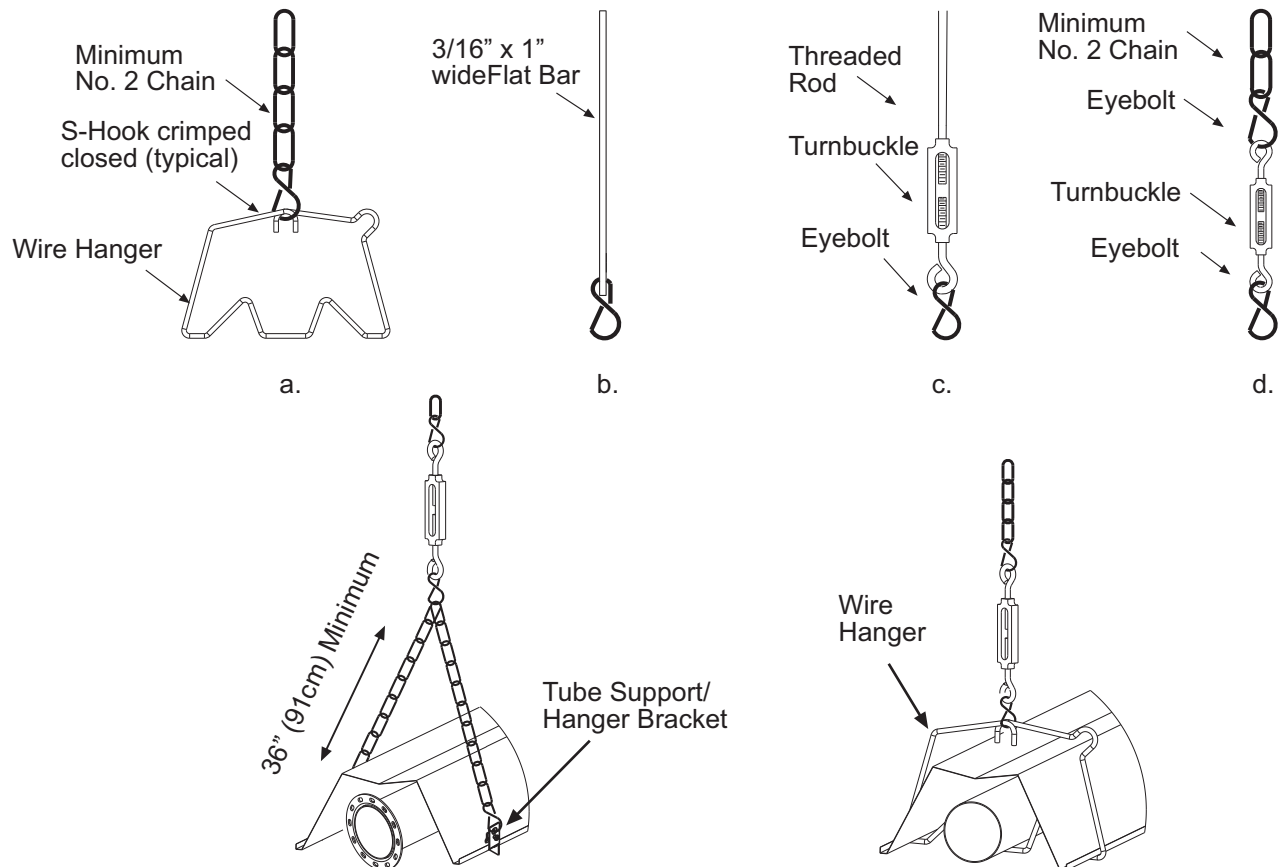

10.0) ASSEMBLY OF TUBE SECTIONS

! CAUTION



CUT HAZARD

Sheet metal parts, particularly reflectors and vent have sharp edges. Always use gloves when handling.

Failure to do so may result in death, serious injury or property damage.

During field assembly of the heater body sections, the recommended procedure is as follows:

1. Before hanging heater sections, first determine the actual layout of the system (see Sections 7.0) & 8.0) for details). Consideration must also be taken for flue pipe, fresh air ducting, gas piping, clearances to combustibles, etc. before hanging heater. Typical suspension methods are shown in Section 9.0).
2. Hang each tube section individually. **DO NOT** attach the heater tube sections together on the ground and attempt to hang the entire system.
3. The first 10' tube section must be aluminized steel (with 12-radial hole flange) as the primary heat exchanger and the control box connected directly to these tube sections. **Failure to attach the control box to the flange end as indicated above will void the manufacturer's warranty.**
4. Place a tube support/hanger bracket on the end of the heat exchanger tube having the mounting flange. Align the tube such that the welded seam is facing down toward the ground. **Failure to assemble the tube with the seam facing down will VOID the manufacturer's warranty.**
5. Space the tube support/hanger bracket 6 inches from center of its slotted holes to the front face of the mounting flange. Secure the tube to the support/hanger bracket using a "U" Bolt clamp and two (2) 5/16-18 nuts provided. For U-tube configuration, see typical assembly overview illustration in Section 8.2)
6. Suspend the chain to attach the wire hanger and the tube support bracket. Insert the tube into the wire hanger and then raise the tube support bracket end up to the suspension chain, use "S" hooks to attach the wire hanger and tube support bracket to the chain.

! CAUTION

Failure to assemble the tube with the seam facing down will VOID the manufacturer's warranty.

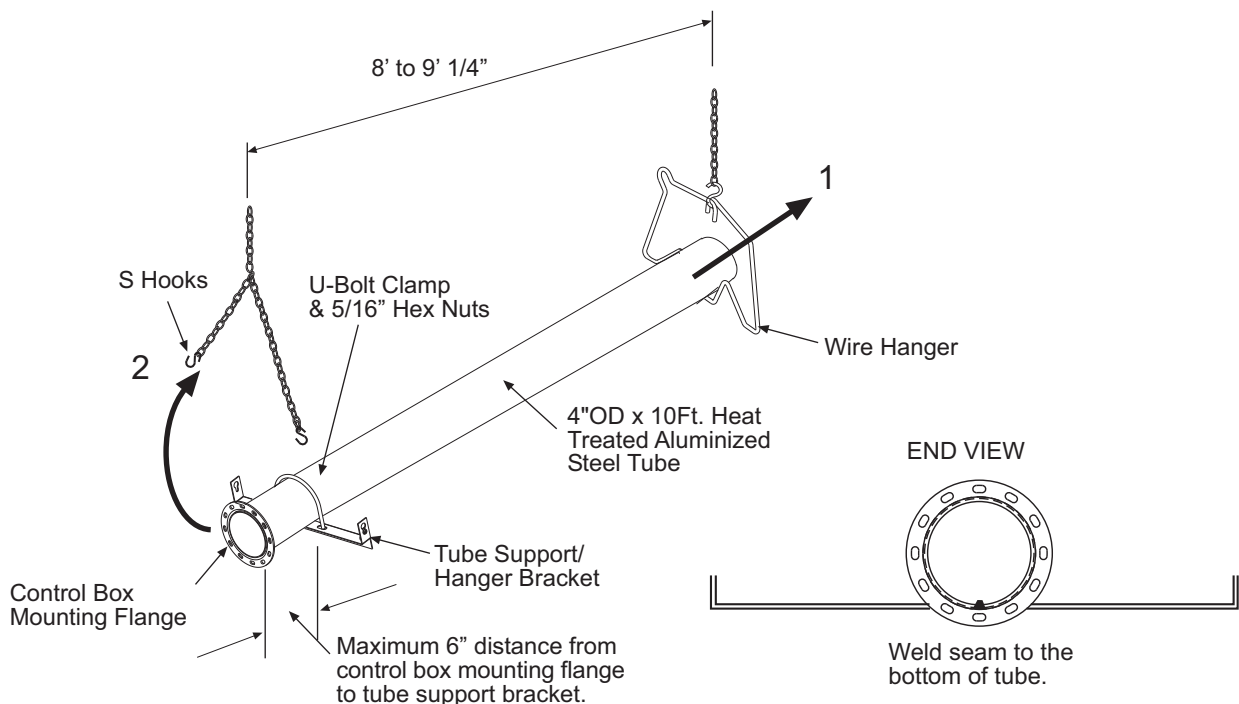

10.1) ASSEMBLY OF EXTENSION SECTIONS

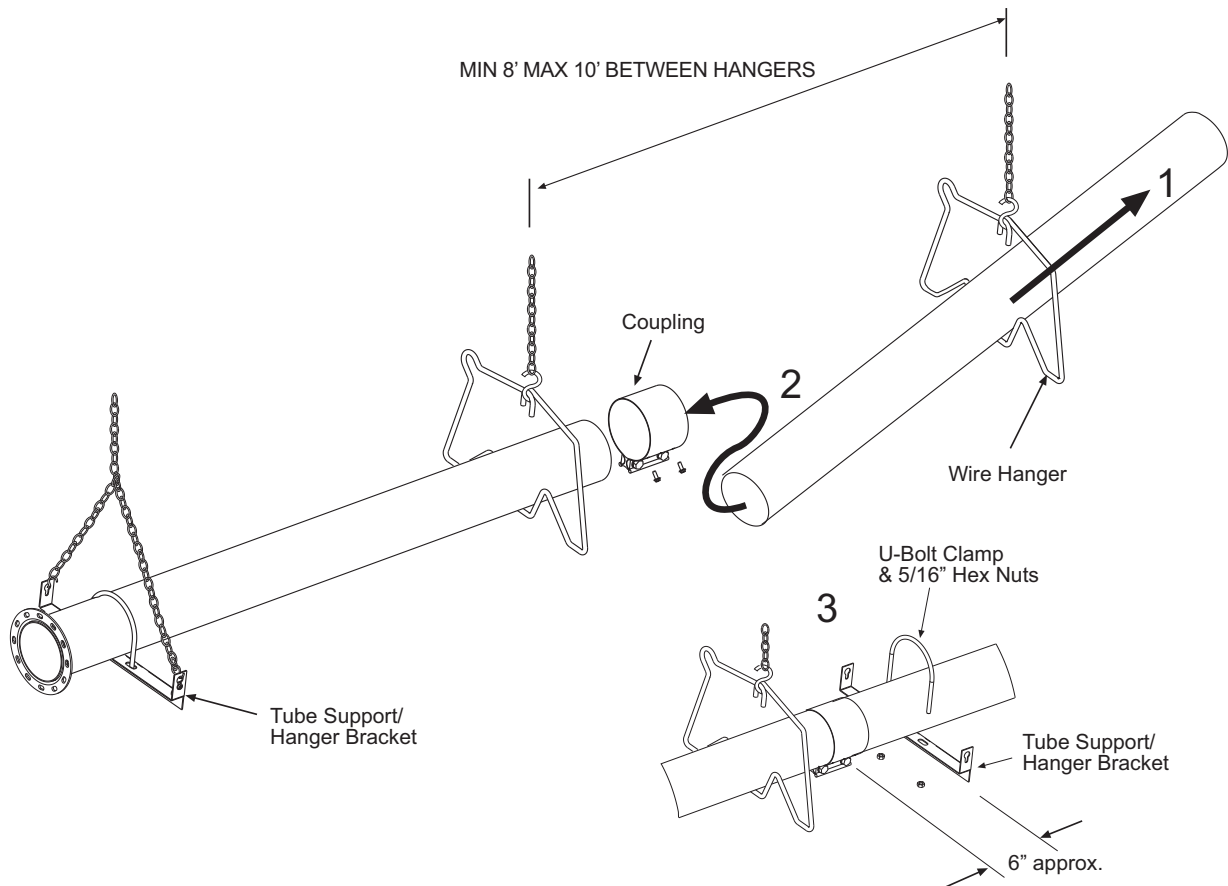

See typical assembly overview (Section 8.0) for typical complete assembly. Assemble additional extension sections as required for all systems. (See Sections 7.0) and 8.0) for typical layout details.)

Join the tube sections together and secure with tube couplings as described below:

! WARNING

The following coupling tightening instructions **MUST** be followed properly to ensure the integrity of the tube connections. **Two #10 self-drilling screws MUST** be installed at every coupling as shown in the instructions below. Failure to do so may result in serious injury or property damage.

1. Place the compression coupling over the end of the tube.
2. Use the small hole at the centerline of the coupling to check that the coupling is inserted correctly.
3. Partially tighten the bolt nearest the end of the tube (approximately half closed).

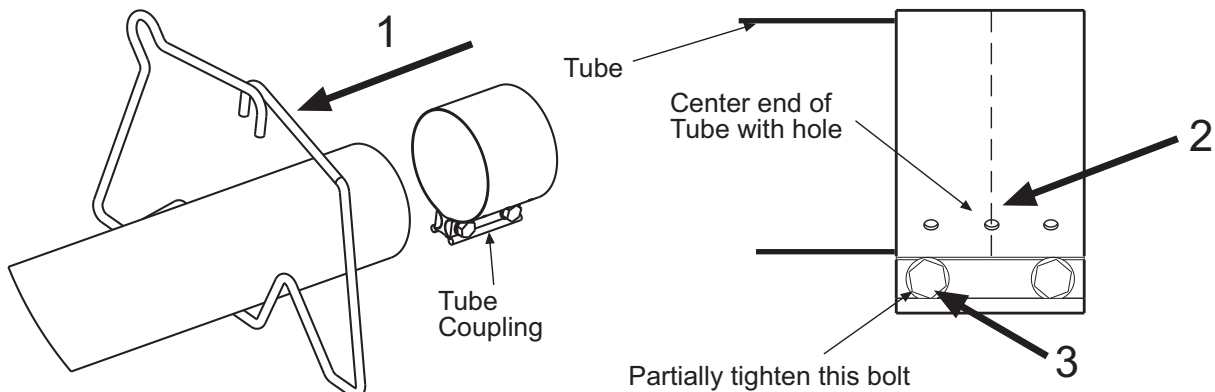

4. Slide the next tube into the coupling.

5. Make sure both tube ends are butted together.
6. Finish tightening both bolts to 40-60 ft.lbs. torque to ensure a complete seal.
7. Use the two Self-drilling screws through the pre-punched holes to secure the tubes in the coupling.

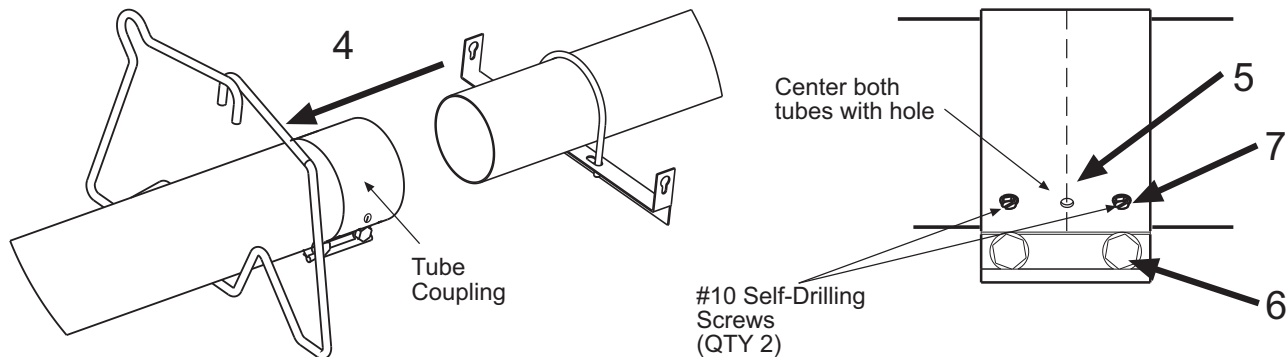

8. Check to ensure that the hardware is completely closed and the band is seated on the reaction block and interference pins as illustrated above.
9. Once all the heater body sections are attached, make sure that the heater system is level. If it is not, slight adjustments can be made using the turnbuckles. (See Section 9.0)

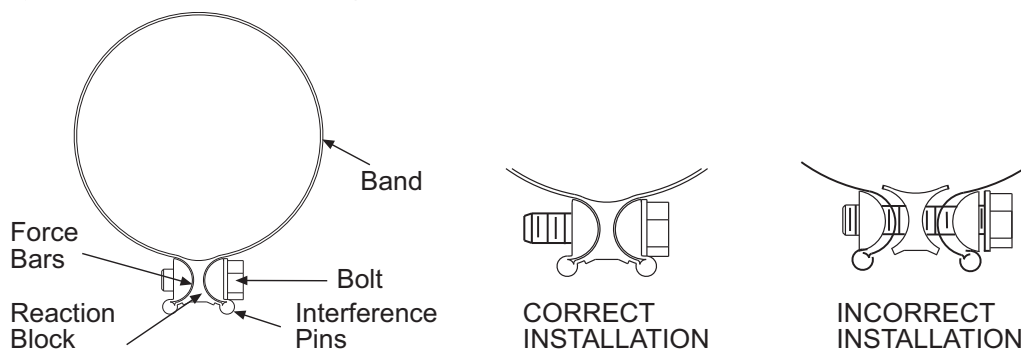

CAUTION

Important: NEVER reuse a coupling. Always install a new coupling only and torque as per instructions above and the diagrams above.

10.2) ADDING REFLECTORS

1. Slide the reflectors on the tube support/hanger brackets and through the wire hangers.
2. The tube at the coupling joints must be covered. Slide the reflectors together and provide an overlap of two (2") inches for the first reflector overlap after the control unit. All remaining reflector overlaps will be approximately one (1") inch. This will allow for the natural expansion and contraction of the heater when in operation. **Note: The heaters can expand and contract up to 1-3/4 inch.** See Detail "B" for the correct installation of reflector overlaps.

- Secure the reflectors as shown in Detail "A" using #10 x 1/2" self-drilling sheet metal screws at each tube support/hanger bracket.

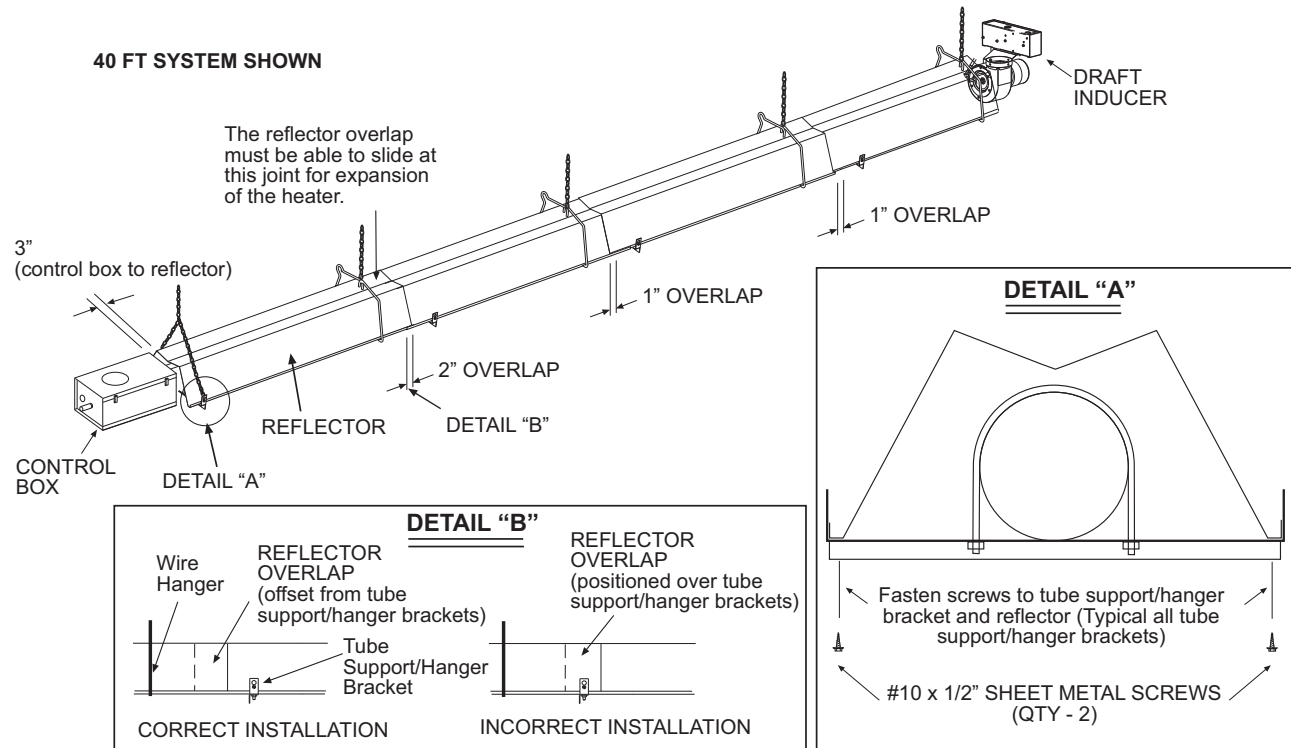

10.3) ADDING OPTIONAL 90° ELBOW (SIS ONLY)

- The optional 90° elbow must be located a minimum of 10 ft. after the control box.
- Hang the body sections in a 90° ("L") shaped pattern. Allow spacing for the elbow. The distance from one end of the elbow to the centerline of the opposite leg is 13" as shown.
- Join the tube ends of the body sections and the elbow together and secure with tube couplings as described in Section 10.1).

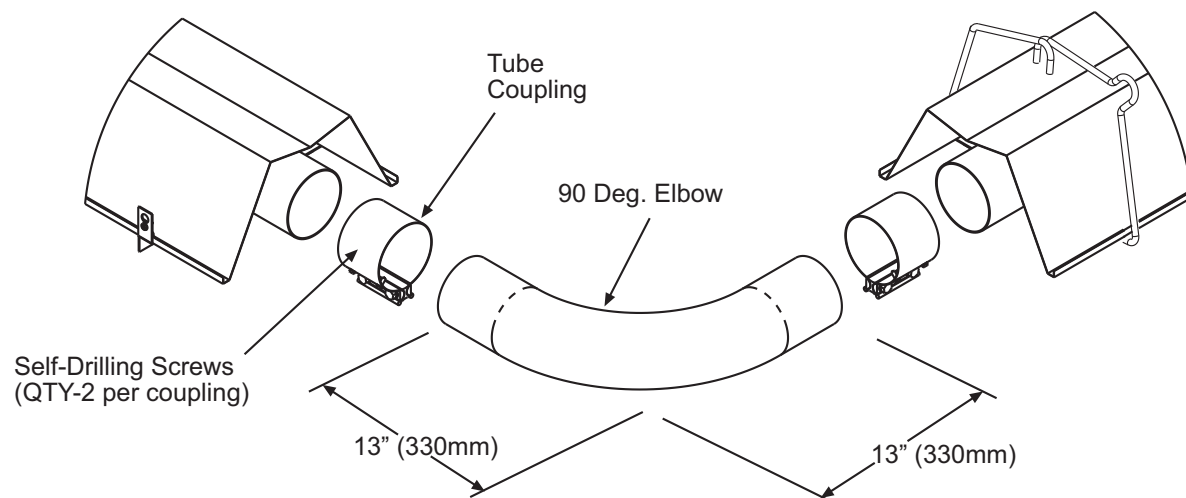

10.4) ADDING OPTIONAL CORNER REFLECTOR (SIS ONLY)

1. Place the corner reflector over the reflectors of both body sections.
2. Secure by sliding speed clips on the reflector edges. One speed clip is required for each side of reflector.
3. The corner reflector can be used only when the long axis of the heater is level and mounted in a horizontal position.

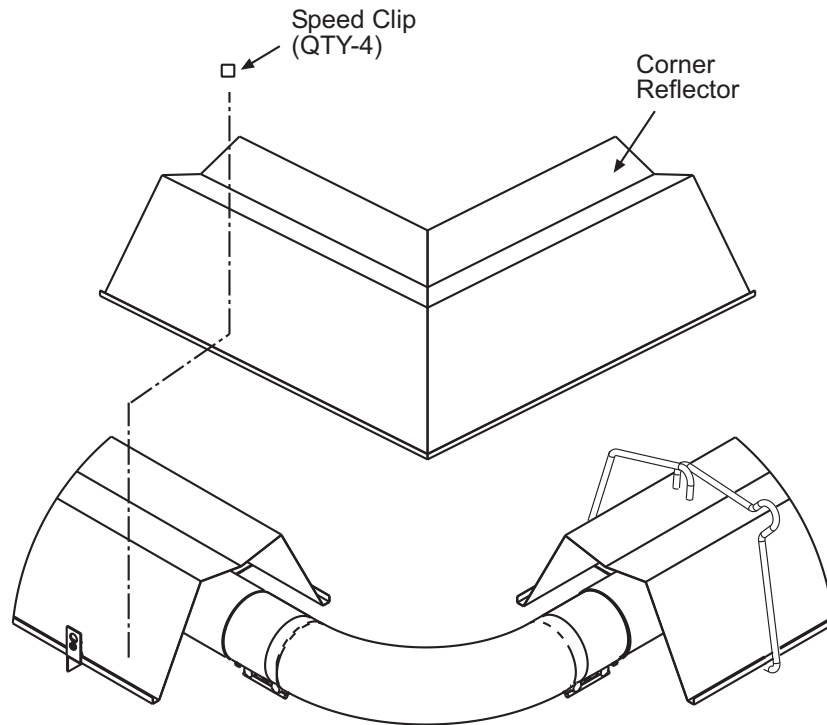

10.5) ADDING 180° U-BEND (SIU ONLY)

1. Hang body sections parallel with each other. The centerline distance from tube at each body section should be 18" as shown.
2. Join tube ends of body sections and the U-Bend together and secure with tube couplings as described in Section 10.1).

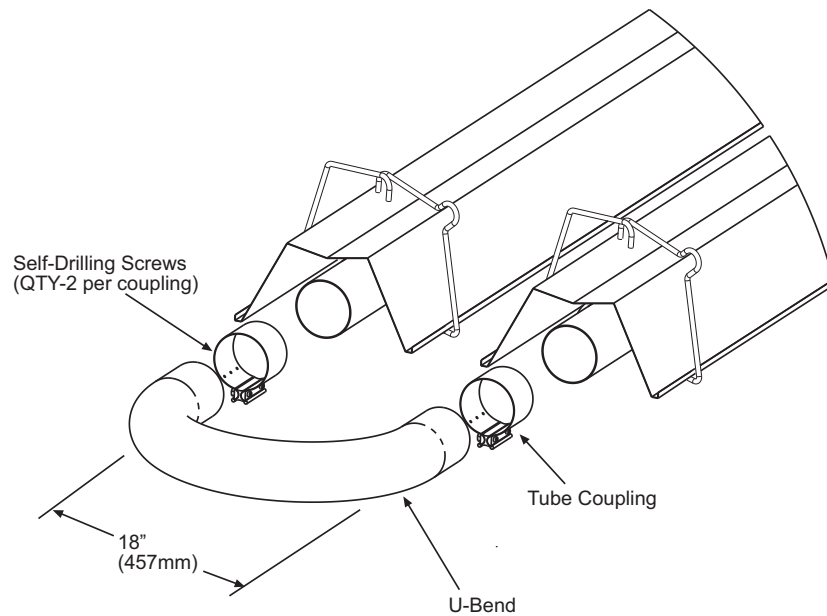

10.6) ADDING OPTIONAL U-BEND REFLECTOR (SIU ONLY)

1. Place the **U-Bend Reflector** over the reflectors of each body section with the end resting next to the tube wire hangers as shown.
2. Slide the speed clips on the reflector edges towards the end of the body section reflectors. Two speed clips are required for each side of the **U-Bend Reflector**. Make sure that the speed clips fit tightly over both the **U-Bend Reflector** and the reflector on each body section. Use two self-drilling screws to permanently secure both sides to the reflectors.
3. Place the **End Reflector** flush with the **U-Bend Reflector** as shown. **Note:** Clearance between end of the **U-Bend Reflector** and the **U-Bend** must be a minimum of **1"**. Secure by sliding speed clips onto the end reflector edges. Evenly space the speed clips on the sides (two each side) and top (three each) of the reflectors to provide a snug fit.

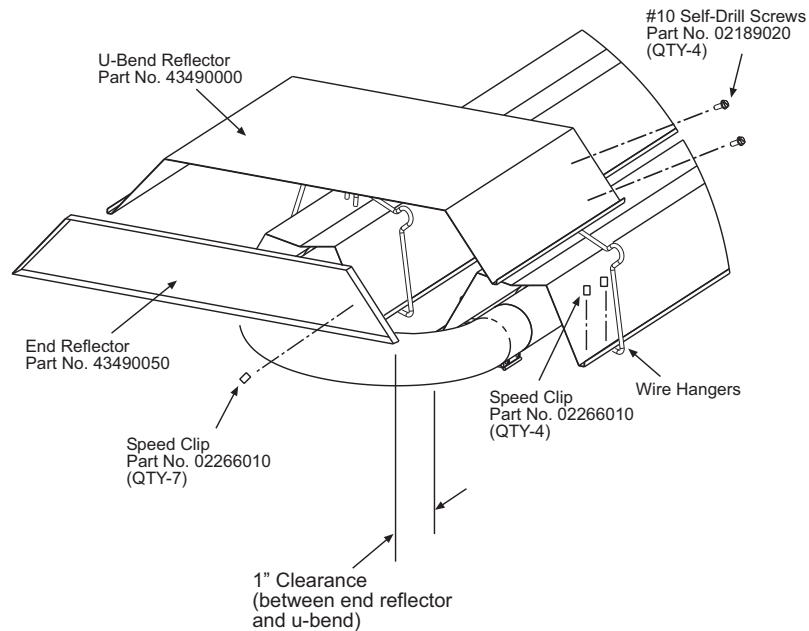

11.0) ATTACHING CONTROL BOX ASSEMBLY

1. Attach the control box and gasket to end of tube flange and secure with 1/4-20 locknuts. **NOTE: The control box must be mounted to a 10 ft. aluminized steel body section regardless of configuration used. Failure to attach the control box to the flange end as indicated above will void the manufacturer's warranty.**
2. A 3/8" connector is located on the left side of the control cabinet to provide strain relief for field wiring to the draft inducer junction box (refer to Section 16.0) on Electrical Connections and Connection Wiring Diagram for wiring between the control box and the draft inducer.)
3. Assemble the end reflector (optional on SIS/SIU series) flush with the end of the main body reflector. Secure by sliding speed clips onto the reflector edges. Evenly space the speed clips on the sides (one each side) and top (two required) of the reflectors to provide a snug fit. Leave a 3" space between the end reflector and the control box assembly.
4. The control box must be mounted with the perforated fresh air plate on top, facing the ceiling.

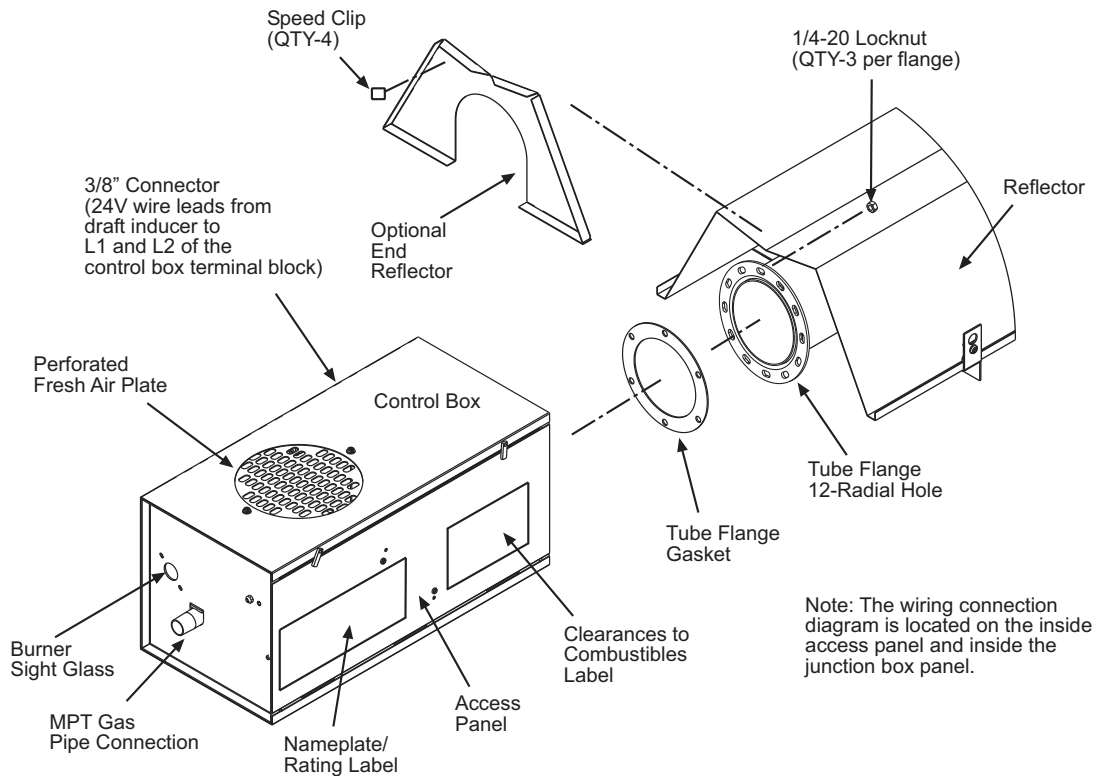

5. The heater can be mounted **horizontally** or at an angle of up to **45 degrees** maximum from horizontal.

When angle mounting, the **control box** must be positioned **upright** as shown below. **Failure to install the control box in an UPRIGHT position will VOID the manufacturer's warranty.** For additional instructions see Section 13.0) for multiple hanging and draft inducer positions.

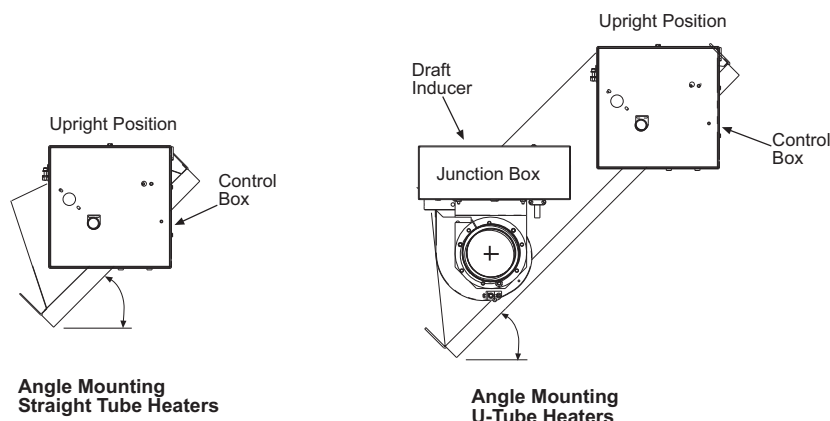

6. **Control box** can be installed in lower side when angle mounting. Please ensure that there is adequate clearance to open the **control box** access panel for servicing the heater.

12.0) ATTACHING DRAFT INDUCER ASSEMBLY

1. Slide the draft inducer flange over the end of tube. Rotate the flange until the tightening brackets are in the upright position. Secure the flange by tightening the 1/4-20 screw located on the tightening brackets.
2. Attach the draft inducer assembly and gasket to end of the draft inducer flange and secure with 1/4-20 locknuts. A flue restrictor plate is attached to the draft inducer weld studs. **DO NOT DISCARD RESTRICTOR PLATE** and make sure this remains in place while the draft inducer is being attached to the heater body. **NOTE:** The draft inducer can be mounted in a vertical, a 45°, or a horizontal position. Refer to Section 13.0).
3. The 3/8" connector used to hold the SJO cable will remain to provide strain relief for field wiring of the control box and the draft inducer (refer to the Electrical Connections and Connection Wiring Diagram for wiring between the control box and the draft inducer in Section 16.0).
4. If the heater is to be VENTED to the outside of the building, place the starting collar on the outlet of the draft inducer and secure with the #8-32 screws and nuts. Place the flue pipe directly onto the starting collar, secure with the #8 sheet metal screws, and terminate with an approved vent cap.
5. If the heater is for UNVENTED use, place the exhaust hood (supplied as an accessory) directly onto the outlet of the draft inducer (starting collar is not necessary for unvented use). Secure with the #8 sheet metal screws. **The exhaust hood must be mounted only in an upright position and directed toward the reflector body.**
6. Assemble the end reflector (optional on SIS/SIU series) flush with the end of the main body reflector. Secure by sliding speed clips onto the reflector edges. Evenly space the speed clips on the sides (one each side) and top (two required) of the reflectors to provide a snug fit. Leave a 3" space between the end reflector and the draft inducer assembly.

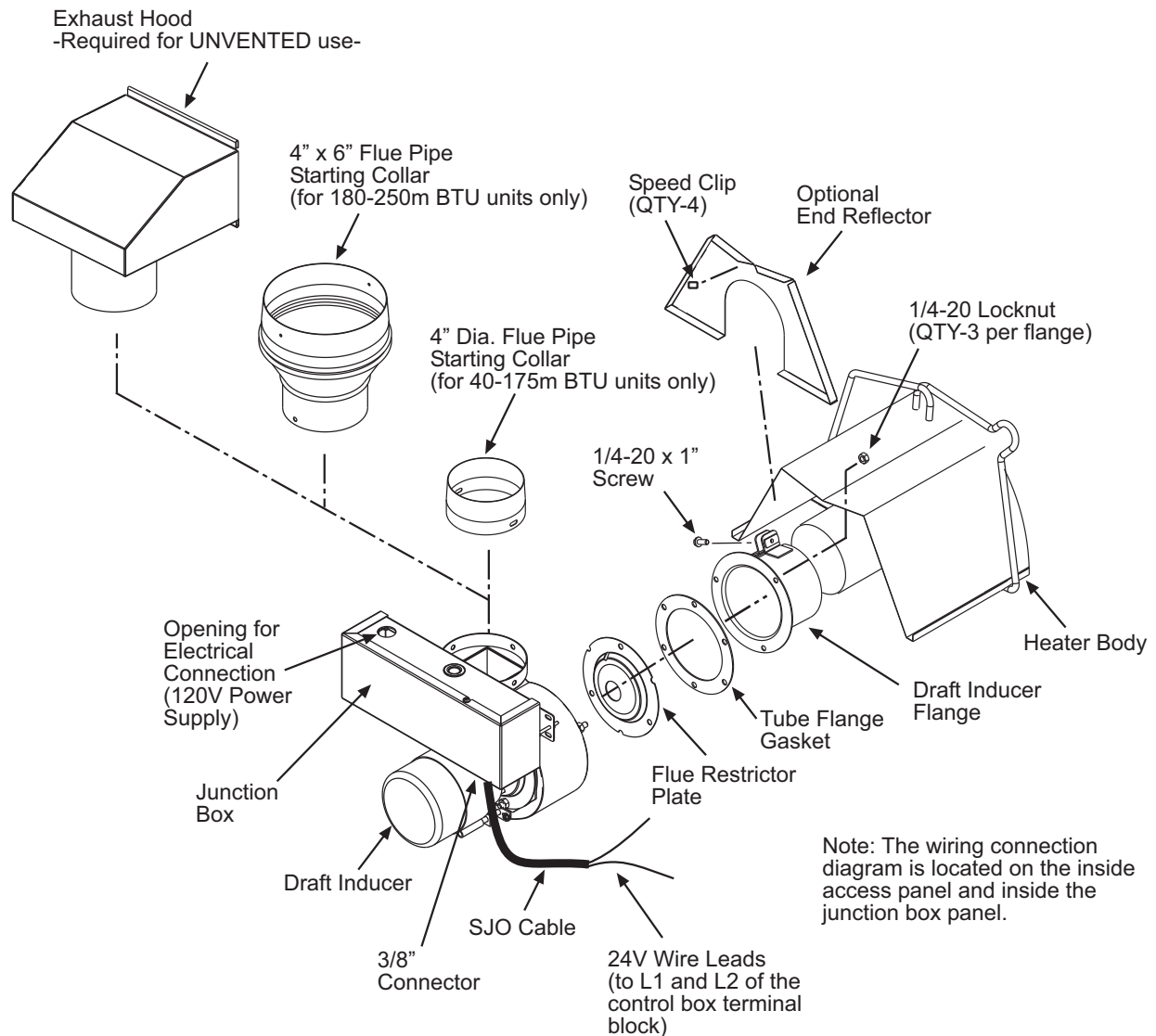

13.0) MULTIPLE HANGING & DRAFT INDUCER POSITIONS



The heater can be mounted horizontally or at an angle of 45° maximum from horizontal. Make sure the long axis of heater is level.

Multiple draft inducer positions can also be used as shown in the diagrams. This allows for the desired configuration of flue venting. Regardless of the position chosen, the junction box must remain horizontal as shown. This may be achieved as follows:

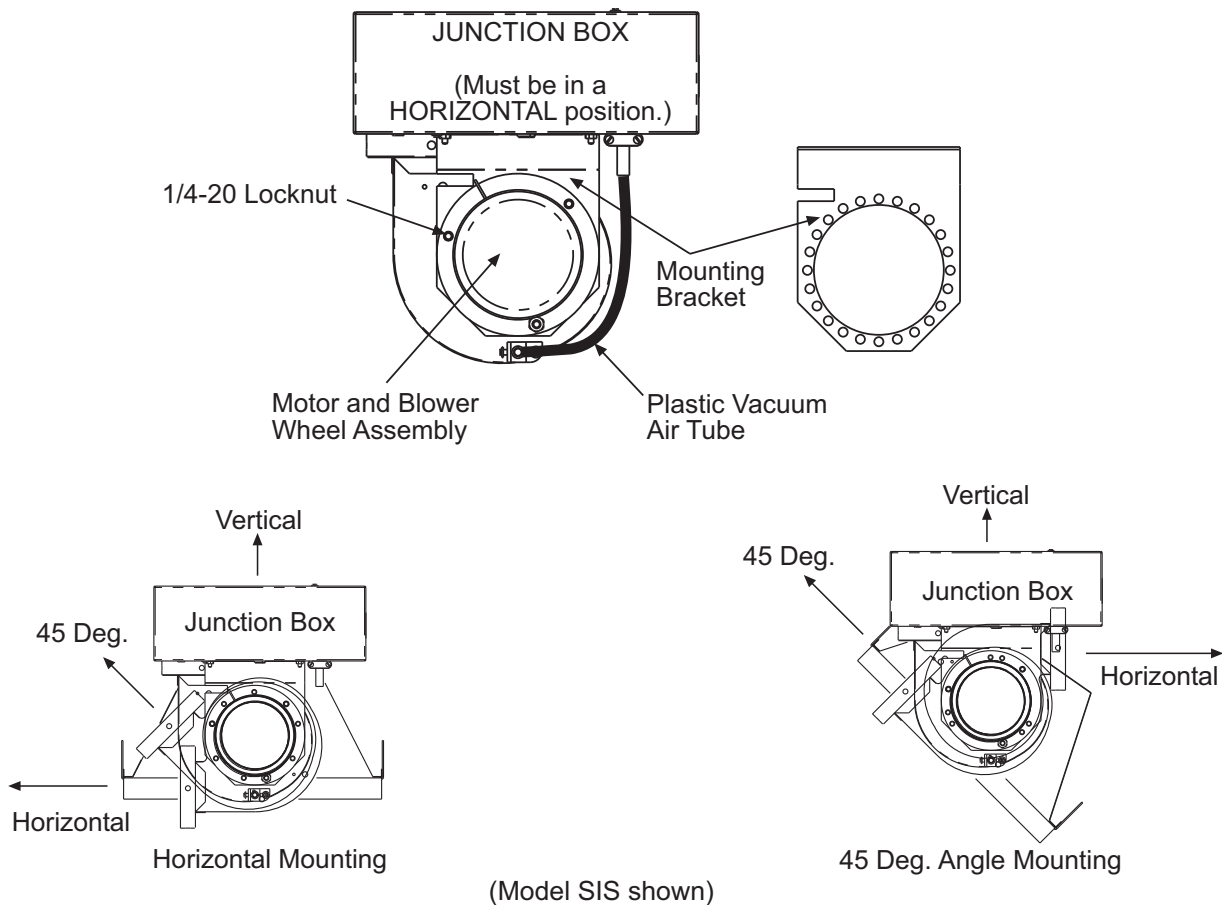
1. Remove the three (3) 1/4-20 locknuts securing the motor and blower wheel assembly.
2. Pull the motor and blower wheel assembly with the motor plate slightly from the end of the housing studs. Use care not to damage the motor leads.
3. Rotate the junction box assembly to the upright position using the multi-hole mounting bracket.
4. Replace the motor and blower assembly. Tighten the locknuts.
5. Horizontal and 45° draft inducer positions can allow the plastic vacuum air tube to sag. The air tube should be shortened to prevent a downward sag that could allow condensation build-up in the tube.

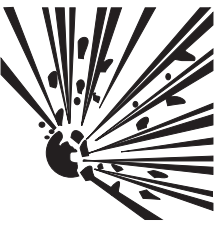

14.0) GAS CONNECTIONS AND REGULATIONS

⚠ WARNING		
		<p>FIRE AND EXPLOSION HAZARD</p> <p>Tighten flexible gas hose and components securely.</p> <p>Flexible metal gas hoses must be installed without any twists or kinks in them. The hose will move during operation of the heater and it can crack if it is twisted.</p> <p>Failure to do so may result in death, serious injury or property damage.</p>

IMPORTANT BEFORE CONNECTING THE GAS TO THE HEATER

1. Connect to the supply tank or manifold in accordance with the latest edition of National Fuel Gas Code (ANSI Z223.1), and local building codes. Authorities having jurisdiction should be consulted before the installation is made. (In Canada, refer to the latest edition of CSA B149.1, Natural Gas and Propane Installation Code.)
2. Check that the gas fuel on the burner rating plate matches the fuel for the application.
3. Check that the gas supply piping has the capacity for the total gas consumption of the heaters and any other equipment connected to the line.
4. Check that the calculated supply pressure with all gas appliances and heaters operating will not drop below the minimum supply pressure required for these heaters. Check inlet supply pressures on Section 15.0).
5. All gas supply lines must be located in accordance with the required clearances to combustibles from the heater as listed on the clearances label of the heater and Section 4.0) of this manual.
6. Pipe joint compounds must be resistant to the action of liquefied petroleum gases.
7. Tube heaters will expand/contract during operation. Where local codes do not prohibit, a CSA or U.L. approved flexible connector supplied with this heater is required for connections between the rigid piping and the heater. A union should be installed before the control box inlet. An approved shut off valve should be installed within 6 feet of the union.
8. The gas pipe, flexible hose and connections must be self supporting. The gas pipe work must not bear any of the weight of the heater or any other suspended assembly.
9. This appliance is equipped with a step-opening, combination gas valve. **The maximum supply pressure to the appliance is 14" W.C. or 1/2 P.S.I.** If the line pressure is more than the maximum supply pressure, then a second stage regulator which corresponds to the supply pressure must be used.
10. After all gas connections have been made, make sure the heater and all gas outlets are turned off before the main gas supply is turned on slowly. Turn the gas supply pressure on and check for leaks. To check for leaks, check by one of the methods listed in Appendix D of the National Fuel Gas Code.
11. If a 2nd stage regulator is used, the ball valve down stream in the supply line must be closed when purging the gas lines to prevent gas seeping through it. If initial gas pressure is higher than 14" w.c. the redundant combination gas valve is designed to lock out. Pressure build-up in the supply lines prior to the heater must be released before proper heater operation.

⚠ WARNING

DO not use an open flame of any kind to test for leaks.

KEY DIMENSIONS AND COMPONENTS OF THE GAS CONNECTIONS

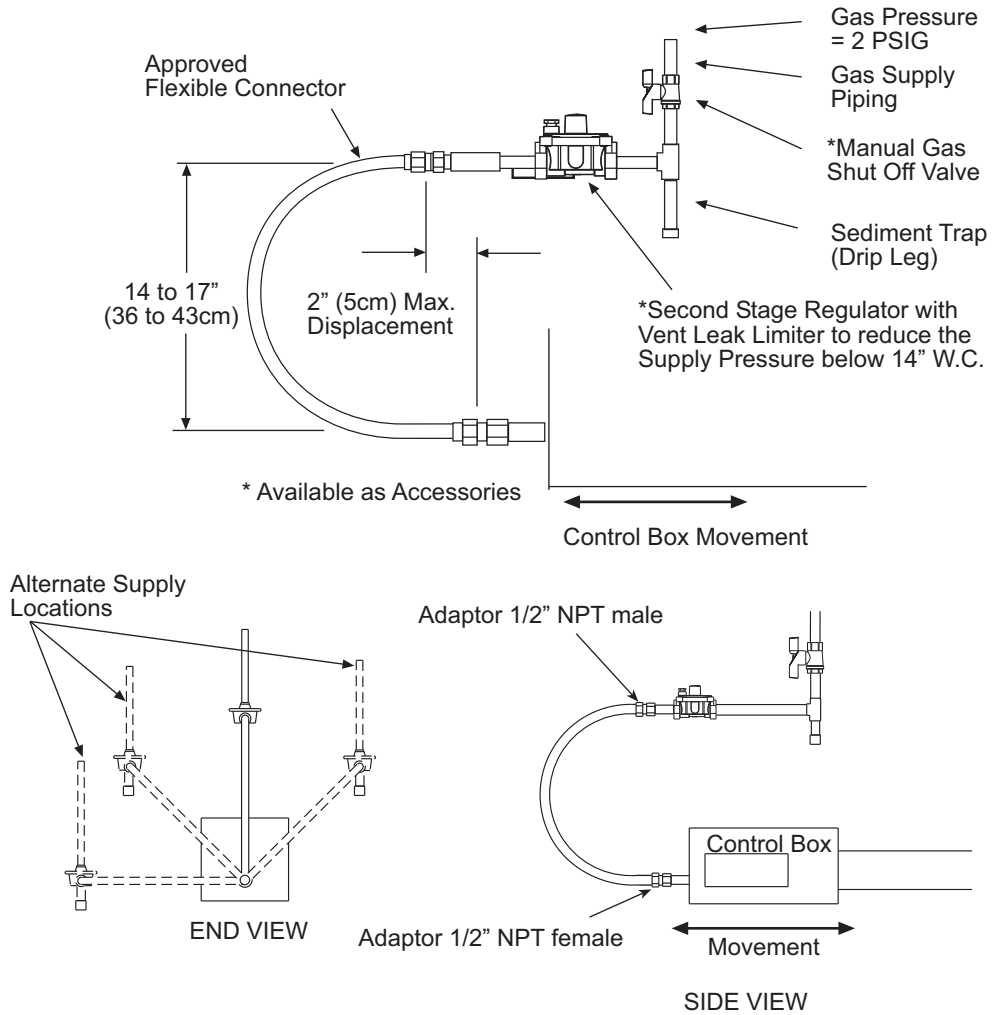

INCORRECT POSITIONS

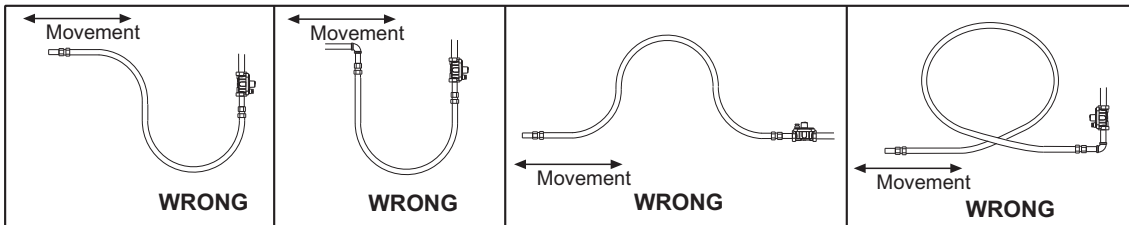

⚠ WARNING

US ONLY: Connector **MUST** be installed in “⌋” configuration. Use only the 36” long connector that was furnished with this heater.

US ONLY: A gas connector certified for use on a tubular type infrared heater per the standard for Connectors for Gas Appliances, ANSI Z21.24/CSA 6.10 is supplied for installation in US only. The gas connector is 36” long and 1/2” nominal ID, and must be installed as shown above, in one plane, and without sharp bends, kinks or twists.

CANADA ONLY: A Type I hose connector should be used that is certified as being in compliance with the Standard for Elastomeric Composite Hose and Hose Couplings for Conducting Propane and Natural Gas (CAN/CGA 8.1) and is of length of 36+/- 6 in (90+/- 15 cm). The gas connector must be installed as shown above, in one plane, and without sharp bends, kinks or twists.

15.0) INSTRUCTIONS FOR PRESSURE TEST GAUGE CONNECTION

SUPPLY PRESSURE

- The installer will provide a 1/8" N.P.T. tapped plug, accessible for test gauge connection immediately upstream of the gas supply connection to the heater.

MANIFOLD PRESSURE – COMBINATION GAS VALVE IS FACTORY SET

- Turn the gas valve to the "OFF" position. Remove the 1/8" plug from the combination gas valve at the **Outlet Pressure Tap** shown below and connect a 1/8" nipple to the tapped hole. Connect the test gauge to the nipple. Turn on the gas supply.

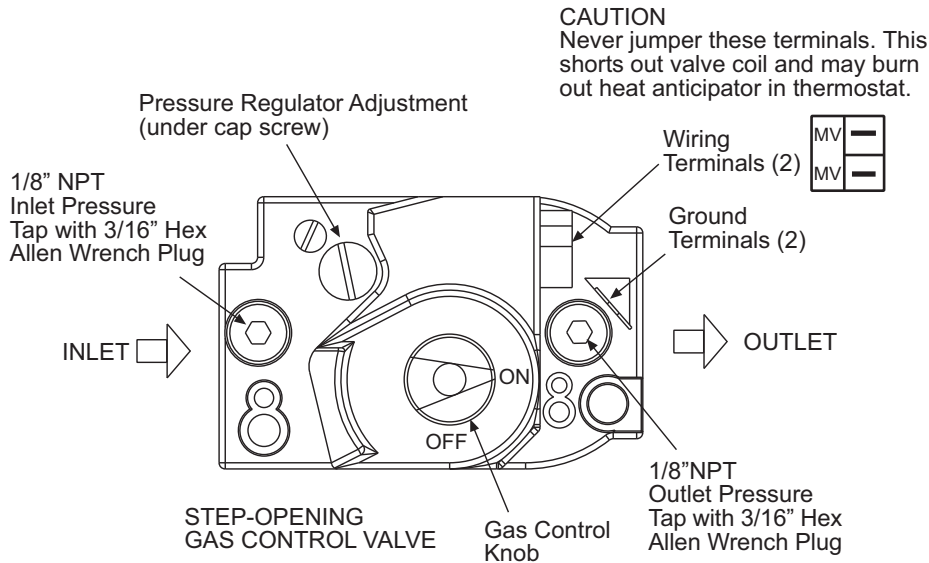

- With the main burner operating, check the burner manifold pressure using a water column manometer. Gauges that measure pressure in pounds per square inch are not accurate enough to measure or set the manifold pressure. All measurements **MUST BE** made when this heater and all other gas burning equipment that is connected to the gas supply system are operating at maximum capacity.
- The combination gas valve is factory set and should not require adjustment.** If full rate adjustment is required, remove the cover screw. Using a small screwdriver, turn the adjustment screw clockwise \curvearrowright to increase or counterclockwise \curvearrowleft to decrease the gas pressure to the burner. Replace the cover screw. **NOTE: The step opening pressure of this gas valve is not adjustable.**
- Check the burner at step pressure, observing burner ignition and flame characteristics. The burner should ignite properly and without flashback to the orifice, and should remain lit.

GAS PRESSURE TABLE			
GAS TYPE	MANIFOLD PRESSURE	SUPPLY PRESSURE	
		Minimum*	Maximum
Natural Gas	3.5" W.C.	5" W.C. ¹	14" W.C.
Propane Gas	10.0" W.C.	11" W.C.	14" W.C.

* Minimum permissible gas supply pressure for purpose of input adjustment.

¹ 7" W.C. for SIS/U 150-175

16.0) ELECTRICAL CONNECTIONS

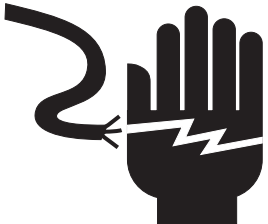
⚠ WARNING	
	ELECTRIC SHOCK HAZARD
	Disconnect electrical power and gas supply before servicing.
	This appliance must be connected to a properly grounded electrical source.
	Failure to do so may result in death or serious injury.

1. All electric wiring shall conform to the latest edition of the National Electrical Code (ANSI/NFPA No. 70), or the code legally authorized in the locality where the installation is made.
2. The unit must be electrically grounded in accordance with the National Electrical Code (ANSI/NFPA No. 70-latest edition). In Canada, refer to current standard C22.1 Canadian Electrical Code Part 1.
3. The wiring providing power to the heater shall be connected to a permanently live electrical circuit, one that is not controlled by a light switch.
4. The power supply to the unit should be protected with a fused disconnect switch or circuit breaker. A service switch, as required by local codes, shall be located in the vicinity of the heater (check local codes for allowable distances) and should be identified as Heater Service Switch. All electrical wiring must be located in accordance with the required Clearances to Combustibles from the heater as listed on the nameplate on the heater.
5. When connecting the **supply circuit** to the heater, wiring material having a minimum size of 14 AWG and a temperature rating of at least 90°C shall be used.

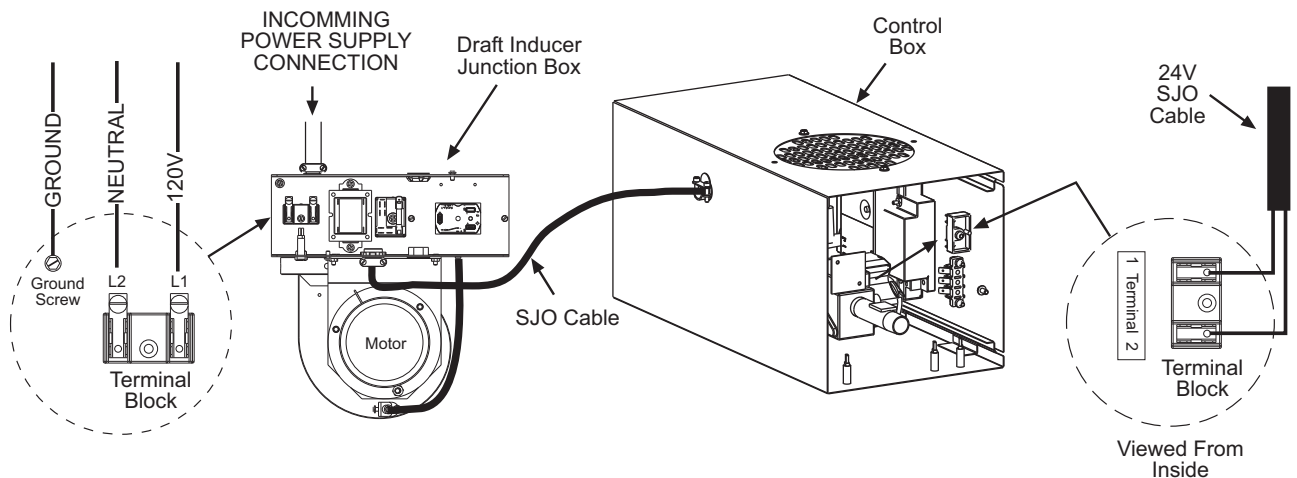

6. **SIS SERIES ONLY:** The installer will provide type SJO wire cable having minimum size of 18 AWG and connect the ends to the draft inducer junction box and the control box. Secure with 3/8" connectors as previously described in the attachment of the control box and draft inducer. Connect wire leads as shown in the Connection Wiring Diagram. The SJO cable should be located and secured to protect it from mechanical damage.

INTERNAL CONNECTION WIRING DIAGRAM — Direct Spark Ignition

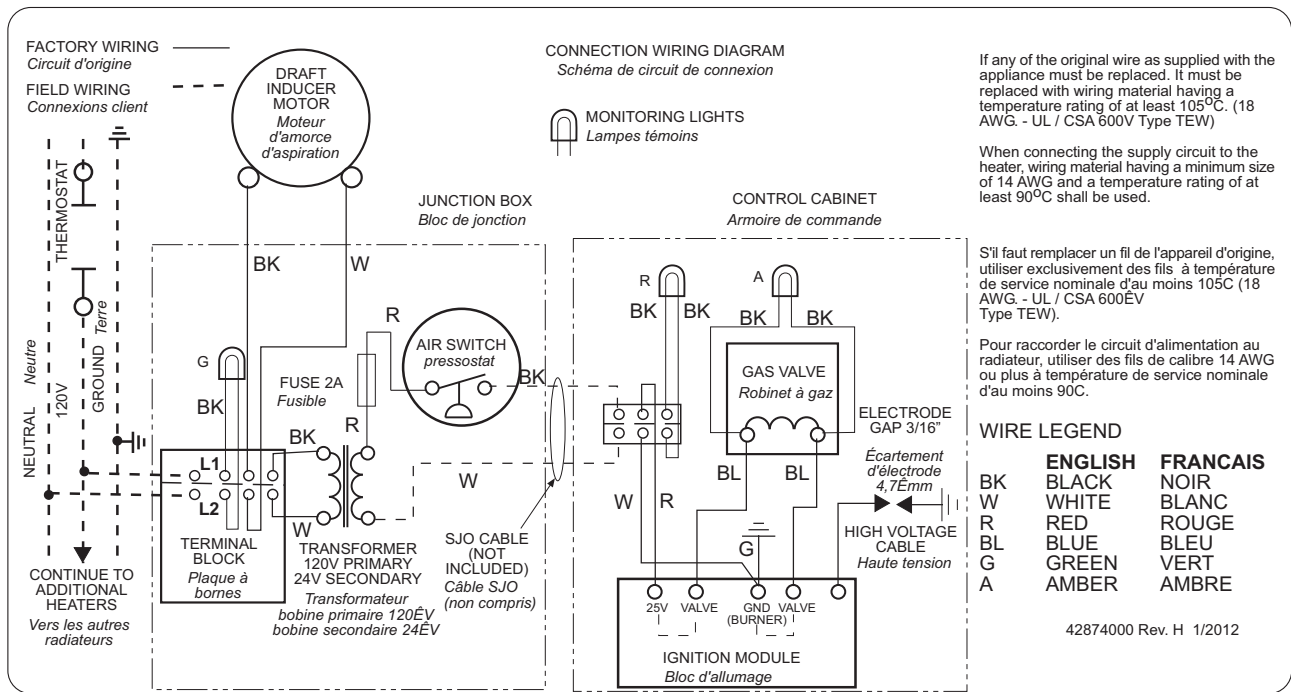

NOTES:

1. If any of the original wire as supplied with the appliance must be replaced, it must be replaced with wiring material having a temperature rating of at least 105°C. (18 Ga. CSA 600V Type TEW)
2. When connecting the supply circuit to the heater, wiring material having a minimum size of 14 AWG and a temperature rating of at least 90°C shall be used.
3. A replaceable 2-amp fuse (1-1/4" long) is fitted to the terminal block located inside the junction box assembly.

SCHEMATIC WIRING DIAGRAM — Direct Spark Ignition

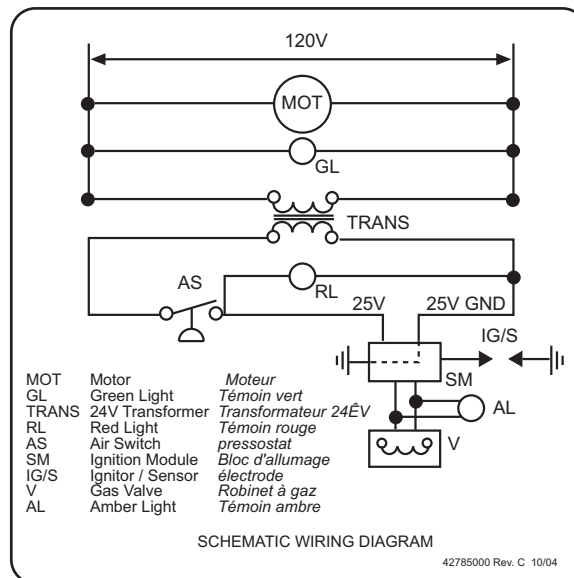

FIELD CONNECTION AND THERMOSTAT WIRING DIAGRAMS

A. LINE VOLTAGE (120V) THERMOSTAT CONNECTIONS – SINGLE HEATER PER THERMOSTAT

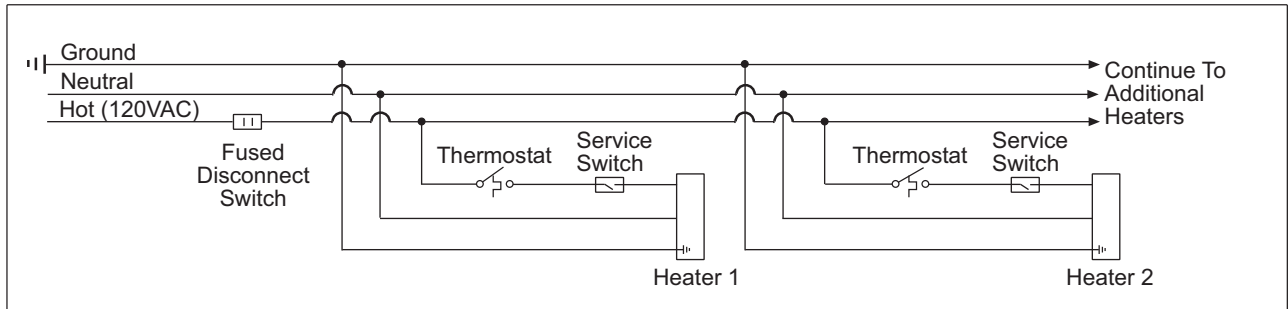

B. LINE VOLTAGE (120V) THERMOSTAT CONNECTIONS – MULTIPLE HEATERS PER THERMOSTAT

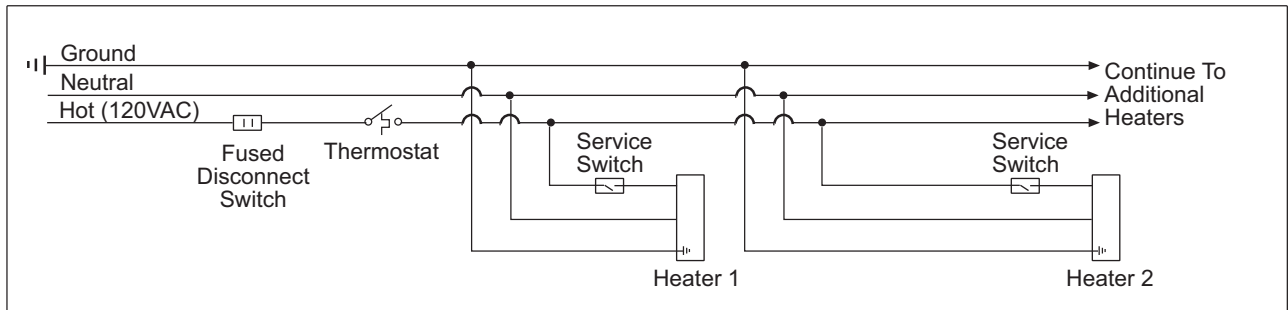

C. LOW VOLTAGE (24V) THERMOSTAT CONNECTIONS – SINGLE HEATER PER THERMOSTAT

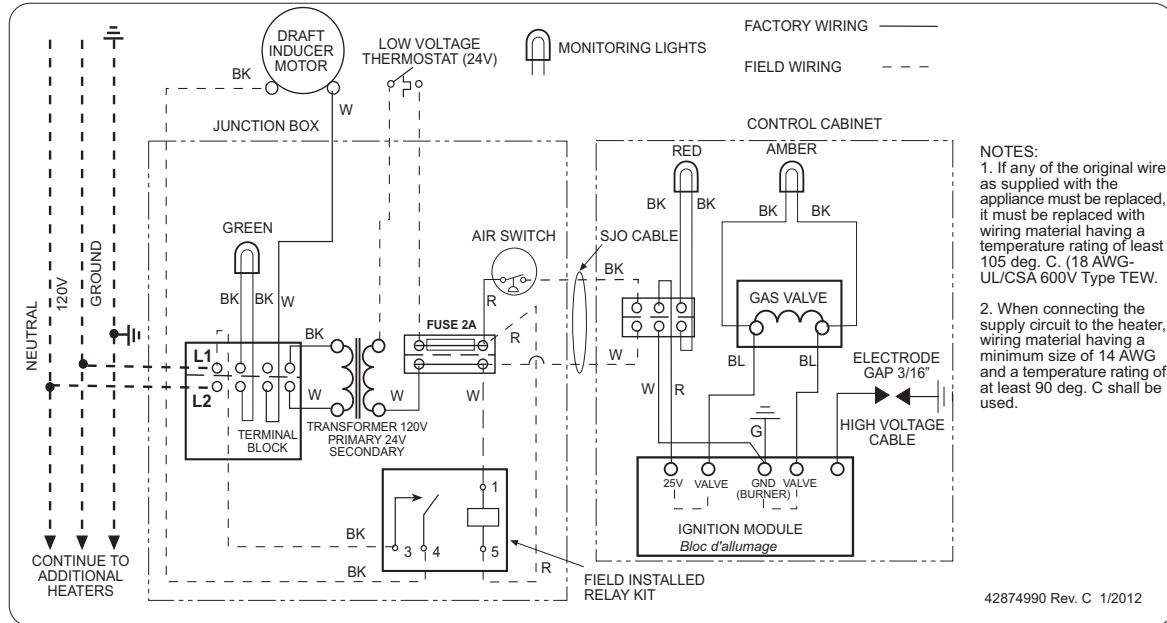

Order 24V Relay Kit (Part No. 43274030) for Low Voltage (24V) thermostat connection.

NOTES:

1. If any of the original wire as supplied with the appliance must be replaced, it must be replaced with wiring material having a temperature rating of at least 105°C. (18 Ga. CSA 600V Type TEW)
2. When connecting the supply circuit to the heater, wiring material having a minimum size of 14 AWG and a temperature rating of at least 90°C shall be used.
3. A replaceable 2-amp fuse (1-1/4" long) is fitted to the terminal block located inside the junction box assembly.

D. LOW VOLTAGE (24V) THERMOSTAT CONNECTIONS – MULTIPLE HEATERS PER THERMOSTAT

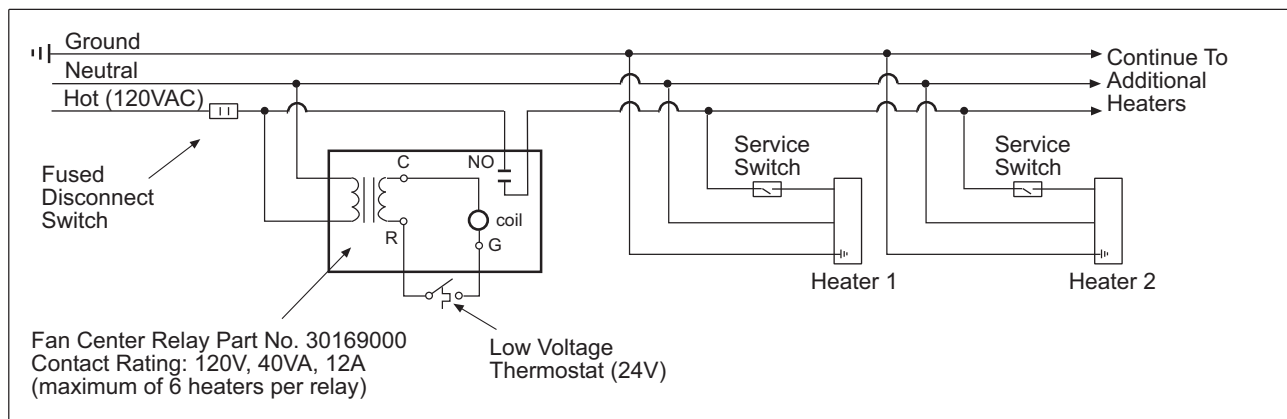

17.0) VENTING

⚠ WARNING

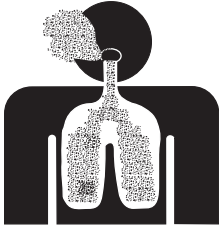

CARBON MONOXIDE HAZARD

Heaters installed in an unvented mode require a minimum ventilation flow of 4 CFM per 1,000 Btu/hr of total installed capacity.

In buildings with airborne contamination the heater must be installed with fresh air for combustion.

Failure to do so may result in death, serious injury, property damage or illness from Carbon Monoxide poisoning.

- A. BASIC FLUE VENTING** — Venting must comply with the latest edition of the National Fuel Gas Code (ANSI Z223.1-latest edition) or the authority having jurisdiction. Other venting references are in the equipment volume of the ASHRAE Handbook.

SINGLE HEATER VENTING (VERTICAL THROUGH THE ROOF)

1. When venting the heater to outside of building through a roof, use single-wall metal pipe. This is to be constructed of galvanized sheet metal or other approved noncombustible corrosion-resistant material as allowed by state or local codes.
2. A vent passing through a combustible roof shall extend through an approved clearance roof thimble. Double-wall, Type B vent must be used for the portion of the vent system which passes through the combustible roof. An approved vent cap must be attached to end of the flue.
3. The maximum equivalent length of vent pipe should be carefully observed. A safety switch in the heater is designed to shut the heater off before excessive flue restriction causes bad combustion. Refer to the Vent Sizing Table for vent pipe diameter.
 - Minimum Equivalent Length = 5 ft. of pipe
 - Maximum Equivalent Length = 100 ft. of 4" pipeUse the following correction factors to obtain the equivalent length:
 - Subtract 15 ft. if the run is horizontal. (maximum horizontal length for 4" pipe is 25 ft.)
 - Subtract 10 ft. for an approved vent cap.
 - Subtract 10 ft. for each elbow beyond 15 ft. from the heater.
 - Subtract 15 ft. for each elbow within 15 ft. of the heater.
4. Joints between sections of piping shall be fastened by sheet metal screws or other approved means and should be sealed to prevent leakage of flue gas into building. Aluminum or Teflon tape suitable for 550°F (3M Company tapes 433 or 363) or silicone sealant is recommended.
5. Avoid locating elbows in the first 5' of vent pipe whenever possible. Limit to (2) 90° elbows. When vent pipe is in a horizontal run, it must have 1/4 inch per foot rise.
6. All portions of the vent pipe shall be supported to prevent from sagging (6' spacing is recommended).
7. When the vent pipe passes through areas where the ambient temperature is likely to induce condensation of the flue gases, the vent pipe should be insulated and a condensation drain should be provided.
8. Minimum clearance for single-wall flue pipe to combustible material shall be 6 inches. This may be reduced when the combustible material is protected as specified in the National Fuel Gas Code or the authority having jurisdiction.
9. Single-wall metal pipe shall not originate in any unoccupied attic or concealed space and shall not pass through any attic, inside wall or concealed space, or through any floor. For the installation of a single-wall metal pipe through an exterior combustible wall, refer to latest edition of the National Fuel Gas Code or the authority having jurisdiction.
10. A venting system shall terminate at least 3 ft. above any forced air inlet located within 10 ft.

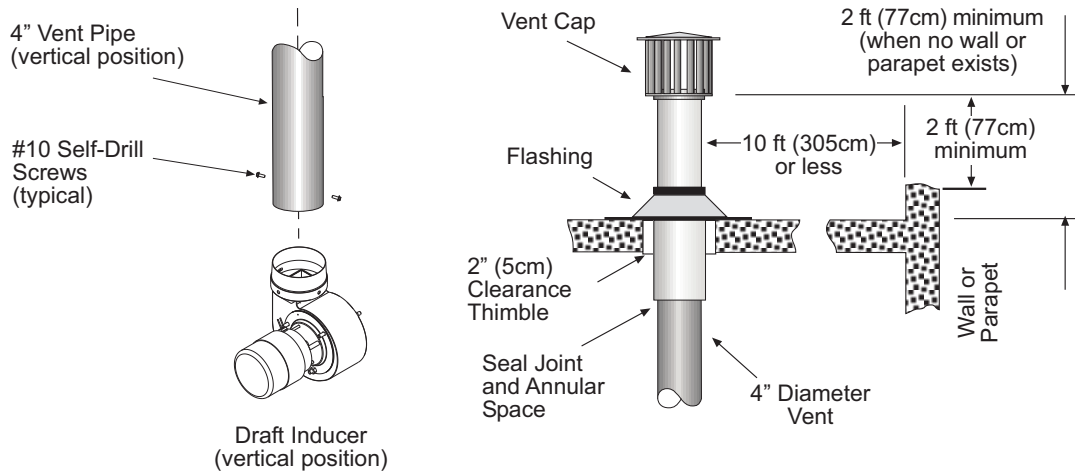

SINGLE HEATER VENTING (HORIZONTAL THROUGH SIDEWALL)

When venting the heater horizontally through a combustible outside sidewall, the same requirements listed previously for venting **Vertical Through The Roof** apply except as follows:

1. A vent passing through a combustible wall must pass through an approved clearance thimble (Air-Jet #4VT or Ameri-Vent #4EWT or other thimbles) that are listed by a nationally recognized testing agency. Double-wall Type B vent must be used for the portion of the vent system which passes through the combustible sidewall.
2. An approved vent cap (Braidert or equal) must be attached to the end of the vent pipe.
 - 4" vent – 25 ft. maximum with one 90° elbow and vent cap
 - 6" vent – 75 ft. maximum with maximum two 90° elbows and vent cap

If other horizontal vent configurations are required, consult the manufacturer.

NOTE: To minimize problems associated with condensation in long horizontal runs, vent pipe can be insulated.

3. When venting through a sidewall, the horizontal vent pipe shall rise not less than 1/4 inch per foot from the start of the vent system to the vent terminal. All portions of the vent pipe shall be supported to prevent sagging. (6' spacing is recommended)
4. A minimum clearance of 6 inches must be maintained between the outside wall and vent cap (18" clearance will provide stability under high wind conditions).
5. The horizontal venting system shall not terminate:
 - Less than 4 ft. (1.2m) below, 4 ft. (1.2m) horizontally from or 1 ft. (30cm) above any door, operable window or gravity air inlet into any building. The bottom of the vent terminal shall be located at least 7 ft. (2.1m) above grade or above snow accumulation level as determined by local codes.
 - Less than 3 ft. (0.9m) from a combustion air inlet.
 - Less than 3 ft. (0.9m) from any other building opening or any gas service regulator.
 - Less than 7 ft. (2.1m) above public walkways.
 - Directly over areas where condensate or vapor could create a nuisance or hazard or be harmful to the operation of gas utility meters, regulators, relief valves, or other equipment. Building materials should be protected from flue gases and condensate.
 - Less than 12" (0.30m) when directly below a combustible overhang.
6. In regions of the country where prevailing winds are consistently higher than 40 mph, it may be necessary to terminate the vent system above the roof level.

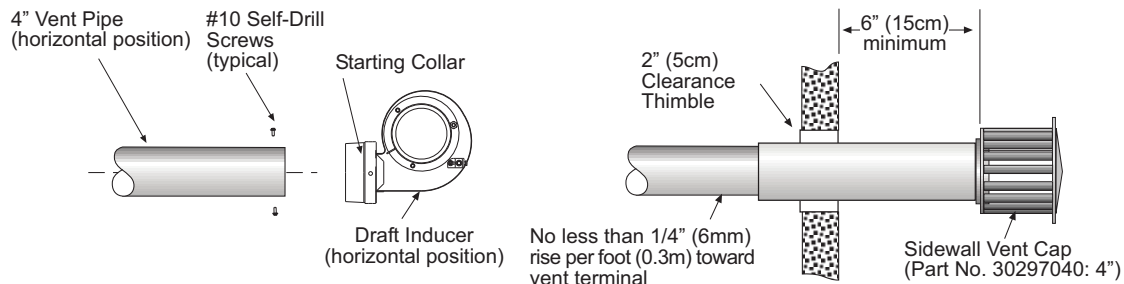

Note: Junction Box is not shown.

MULTIPLE HEATER VENTING (CONNECTIONS INTO A COMMON VENT OR MANIFOLD)

Requirements for venting of multiple heaters are the same as described for **SINGLE HEATER VENTING** except as follows:

1. The common vent size and total vent height is normally determined by the number of heaters per common vent, length of horizontal connector runs, and connector rise. Connector lengths should be as short as possible and have a minimum 1/4 inch per foot rise. Without regard to connector rise and total vent height due to many possible venting configurations, the following should be observed:
 - Common vent pipe & vent connector diameter should be no less than that shown in the following Vent Sizing Table.
 - The connector length should be no more than 75% of the vertical portion of vent above the connector.
 - Where possible, use a Y-connector to the common vent.
2. Material for connectors should be constructed of galvanized sheet metal or other approved noncombustible corrosion resistant material as allowed by state or local codes. All common vent pipe should be insulated flue pipe or double-wall, Type B vent.
3. Avoid unnecessary bends. Limit to two (2) 90° elbows.
4. The entire length of vent connector shall be readily accessible for inspection, cleaning and replacement.
5. Groups of heaters with a common vent must be controlled by a common thermostat.

⚠ WARNING

If any heater connected to a common vent system for multiple heaters is found inoperative, the heater should be disconnected from the vent system and its entrance into the vent system capped.

Multiple Heater Vertical Venting Arrangement

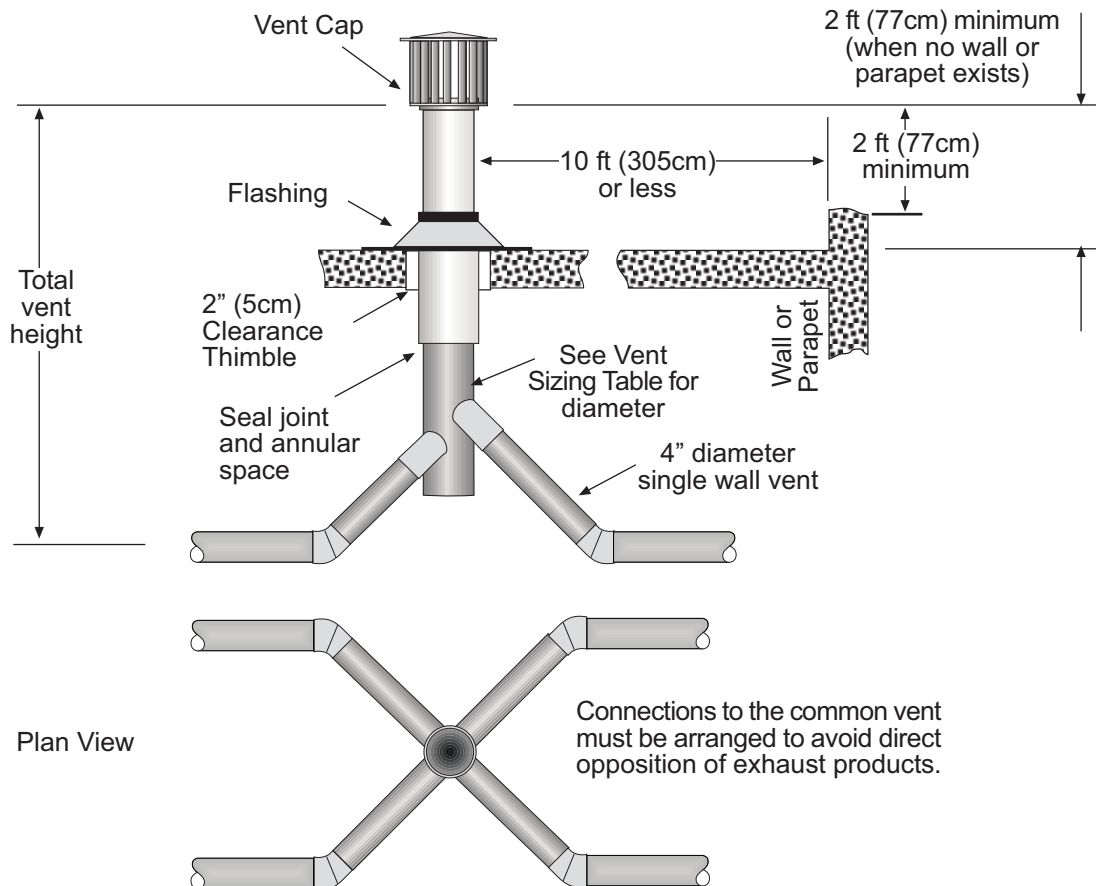

Multiple Heater Horizontal Venting Arrangement

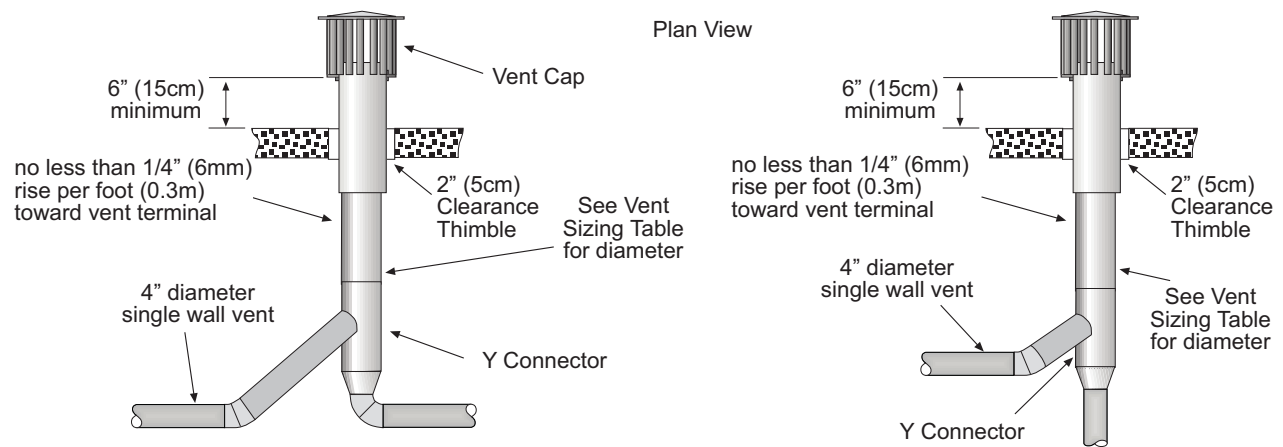

Multiple Heater Venting (Connections into a Manifold)

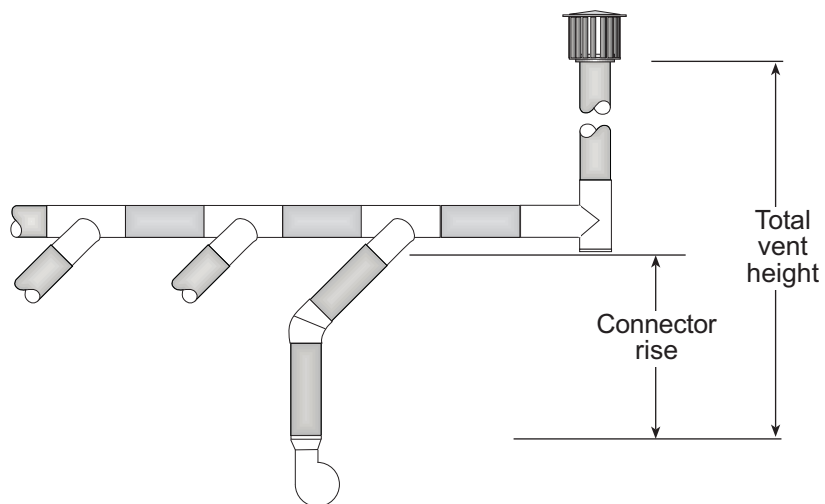

VENT SIZING TABLE — Multiple Heater Venting					
	Number of Heaters				
	1	2	3	4	5
SIS/U50	4"	4"	5"	5"	6"
SIS/U75	4"	5"	6"	6"	7"
SIS/U100	4"	6"	6"	7"	8"
SIS/U125	4"	6"	7"	8"	9"
SIS/U150-175	4"	6"	8"	9"	10"
COMMON VENT DIAMETER (If a size is not available use the next larger size.)					

THE ABOVE ILLUSTRATIONS AND TABLE OF VENT SIZES FOR COMMON VENTING OF MULTIPLE HEATERS ARE IN ACCORDANCE WITH THE NATIONAL FUEL GAS CODE ANSI Z223.1-LATEST EDITION, NFPA 54-LATEST EDITION, EQUIPMENT VOLUME OF 1988 ASHRAE HANDBOOK, CURRENT CAN/CGA-B149.1/2-M86 INSTALLATION CODE, AND AGA PUBLICATION NO. 10M5.85 2.5-2 ON FUNDAMENTALS OF GAS APPLIANCE VENTING AND VENTILATION-REVISED BUT ARE NOT A PART OF THE CSA CERTIFICATION.

- B. INDIRECT VENTING (UNVENTED HEATERS)** — This heater requires ventilation in the building to dilute the products of combustion and provide fresh air for efficient combustion. Where unvented heaters are used, gravity or mechanical means shall be provided to supply and exhaust at least 4 CFM per 1,000 Btu/hr input of installed heaters. Exhaust vents must be located at the highest point above and in the vicinity of the heaters, and the inlet vents must be located below the level of the heaters. An exhaust hood (Part #42924000) must be placed on the outlet collar of the draft inducer or on the existing 4" starting collar when used unvented and **must be mounted only in an upright position and directed towards the reflector body as shown.**

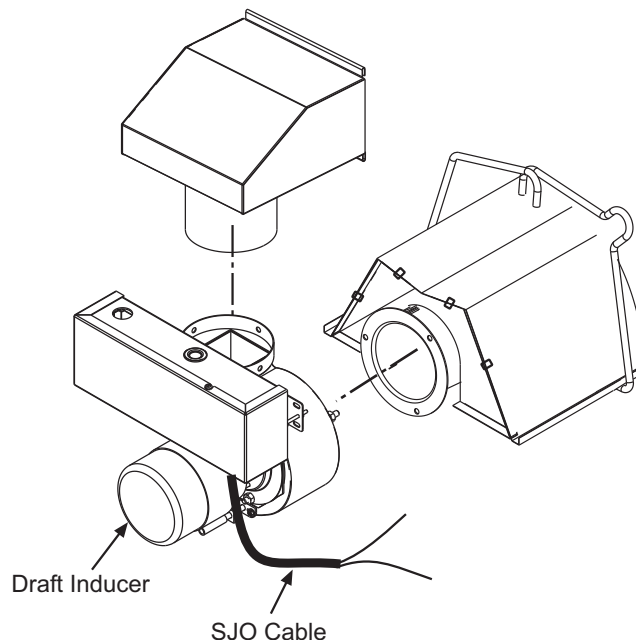

18.0) AIR FOR COMBUSTION

If indoor combustion air is to be supplied for a tightly enclosed area, one square inch of free area opening shall be provided below the heater for each 1,000 Btu/hr of heater input. When outside air is used, the opening below the heater shall be one square inch of free area for each 4,000 Btu/hr of heater input. In contaminated atmospheres or high humidity areas, optional outside air for combustion is recommended. Adequate clearances around the air inlet screen must be maintained at all times. In larger open areas of buildings, infiltration normally is adequate to provide air for combustion.

18.1) DIRECT OUTSIDE AIR FOR COMBUSTION

Outside combustion air should be supplied directly to the heater when the building is subject to negative pressure, or when contaminants or high humidity are present in the building air. These contaminants include paints, solvents, corrosive vapors or any other foreign particles that may cause damage to the heater or result in poor combustion.

Outside combustion air can be brought directly to the heater by a 6" diameter duct less than 50 ft. long or equivalent. This is attached to the 6" diameter starting collar. The starting collar is fitted to the top of the control box cabinet **after first removing and discarding the perforated cover.** An approved vent cap must be placed directly on the end of the outside combustion air inlet pipe. The combustion air inlet should be not less than 3 ft. (0.9m), either vertically or horizontally, from the flue vent termination. The air intake terminal must be located not less than 1 ft. (30cm) above grade. It is good installation practice to supply combustion air from the same pressure zone as the vent outlet. Avoid bringing combustion air to the heater from an attic space. There is no guarantee that adequate combustion air will be supplied.



If the heater is installed less than 2 ft. from the ceiling, a flexible transition section (e.g., flexible aluminum duct) must be provided to allow for expansion/contraction of straight tube heaters (SIS Series).

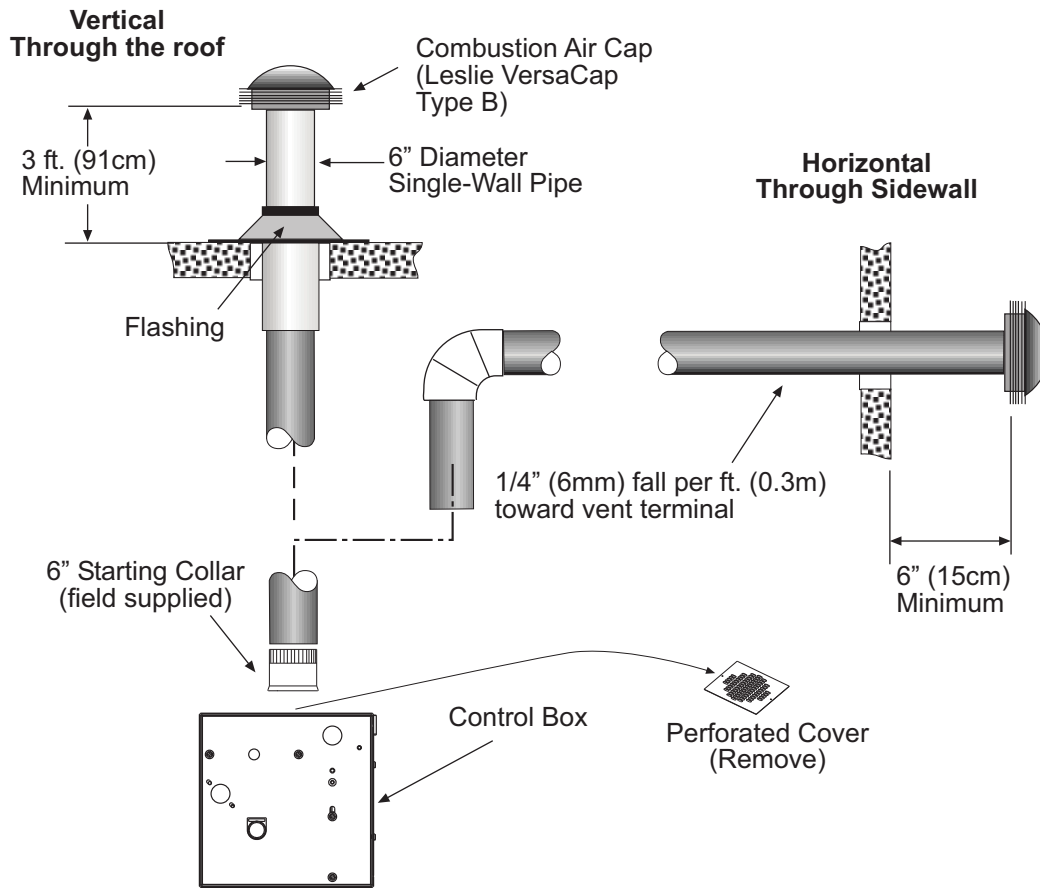
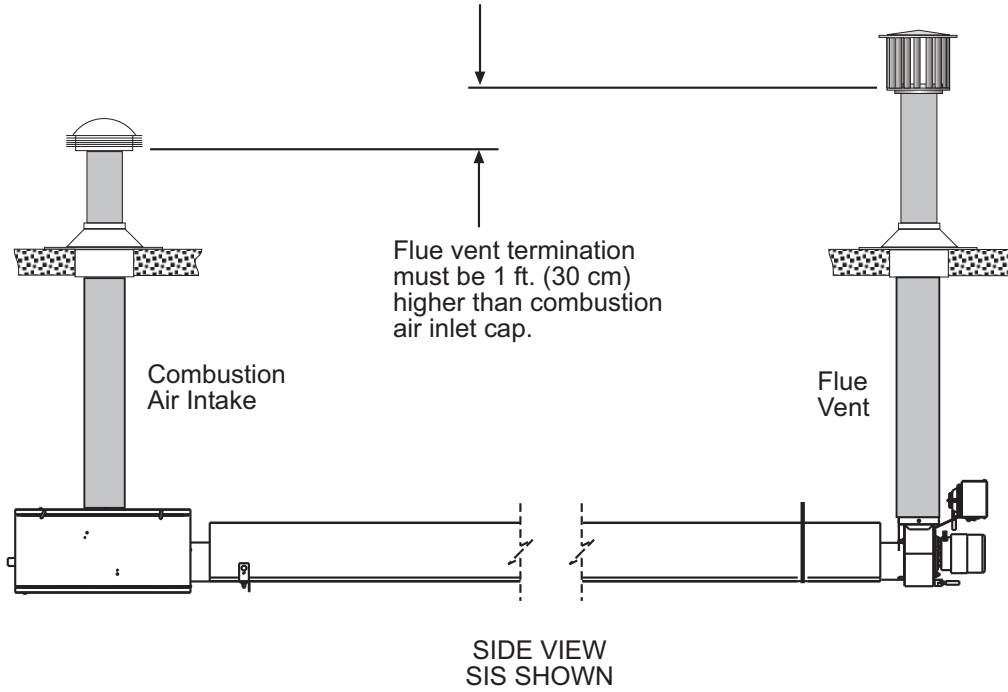

In colder climates, where necessary, insulate the outside combustion air duct. Avoid locating the outside combustion air duct directly above the control box. Provide a capped cleanout T as necessary. In high humidity applications, the control box should be sealed with silicone sealer.

In **multiple heater applications**, the combustion air intake may be ducted individually or common ducted in the same configuration as shown for venting in Section 17.0). For combustion air intake duct sizing, please refer to the **Vent Sizing Table** and use the diameter indicated, based on the number of heaters per duct.

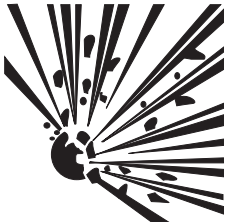

19.0) LIGHTING AND SHUTDOWN INSTRUCTIONS

⚠ WARNING		
		<h3 style="margin: 0;">FIRE AND EXPLOSION HAZARD</h3> <p>Never operate the heater with the access panel open or removed.</p> <p>The access panel must be closed tightly during operation.</p> <p>Failure to do so may result in death, serious injury or property damage.</p>

1. Turn on the gas and electrical supply. Rotate the gas valve knob counter-clockwise  to the "ON" position.
2. Set the thermostat to call for heat. The blower motor will energize.
3. Ignition should occur after the 30-second air pre-purge.
4. If ignition fails, the unit will spark for approximately 21 seconds and go into safety lockout. Turn the thermostat (power) off for 60 seconds to take the system out of lockout.
5. If the heater does not light, manually reset the thermostat or shut off power completely for 5 minutes before attempting to relight.
6. To permanently shut down the heater, rotate the gas valve knob clockwise  to the "OFF" position and turn off the gas and electrical supply.

NOTE: The lighting and shutdown instructions are also shown on the permanent nameplate label attached to the heater control box.

20.0) SEQUENCE OF OPERATION

The chart below shows the sequence of operation for the normal operating cycle.

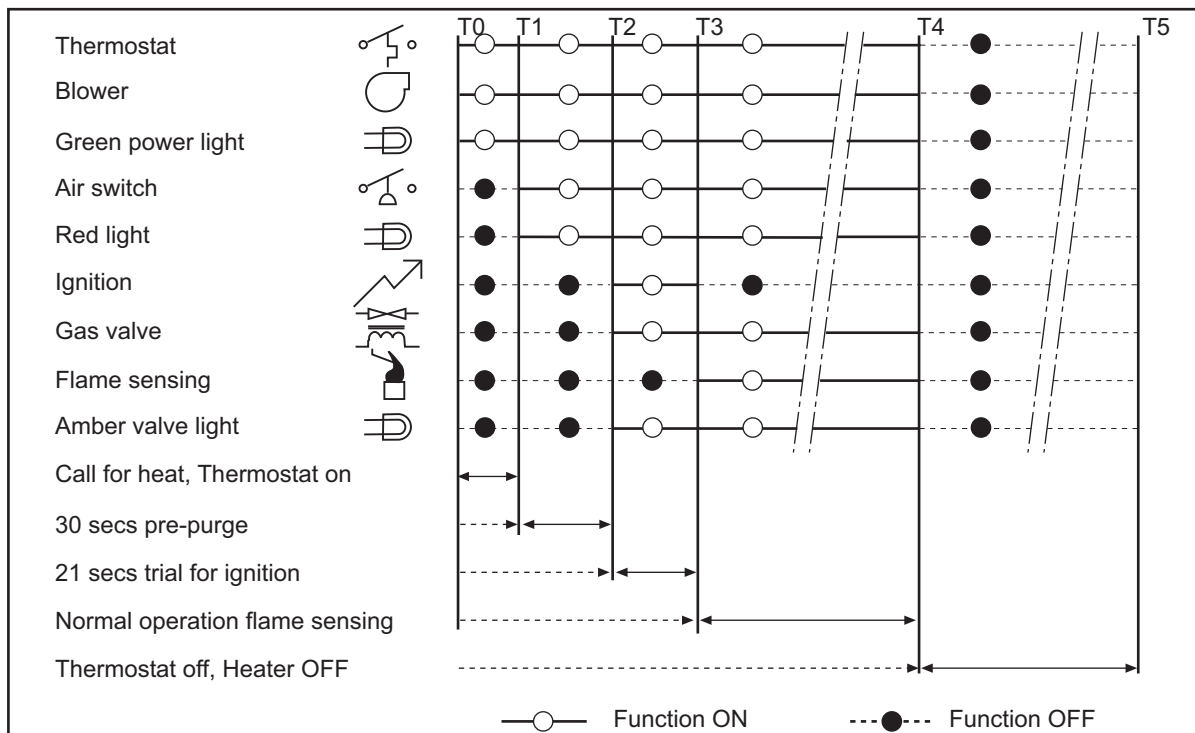

If the flame is not sensed during sequence T3 then the burner will automatically begin ignition sequence T2. If the flame is not re-established the heater will go to lockout.

21.0) CONTROL COMPONENT LOCATION

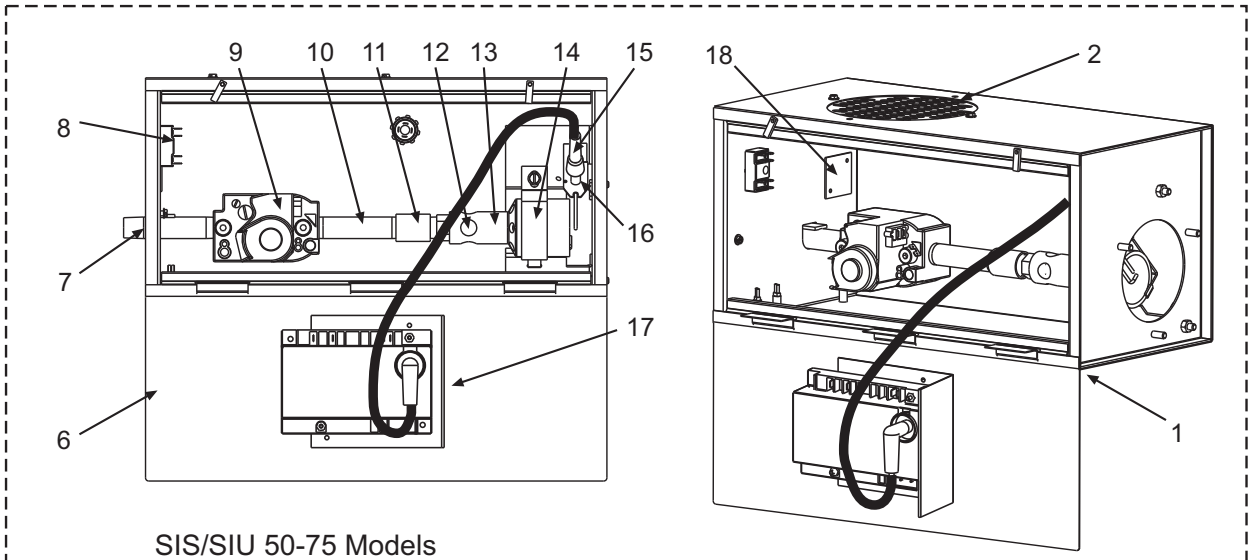
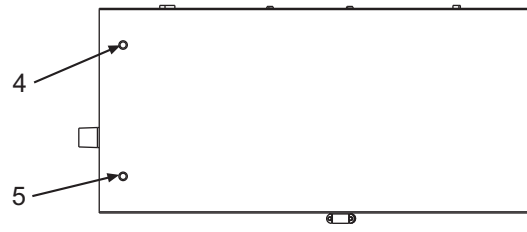
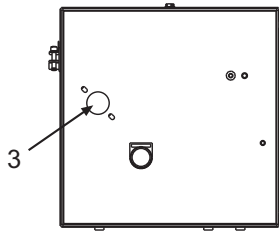

SIS/SIU 50-75 Models

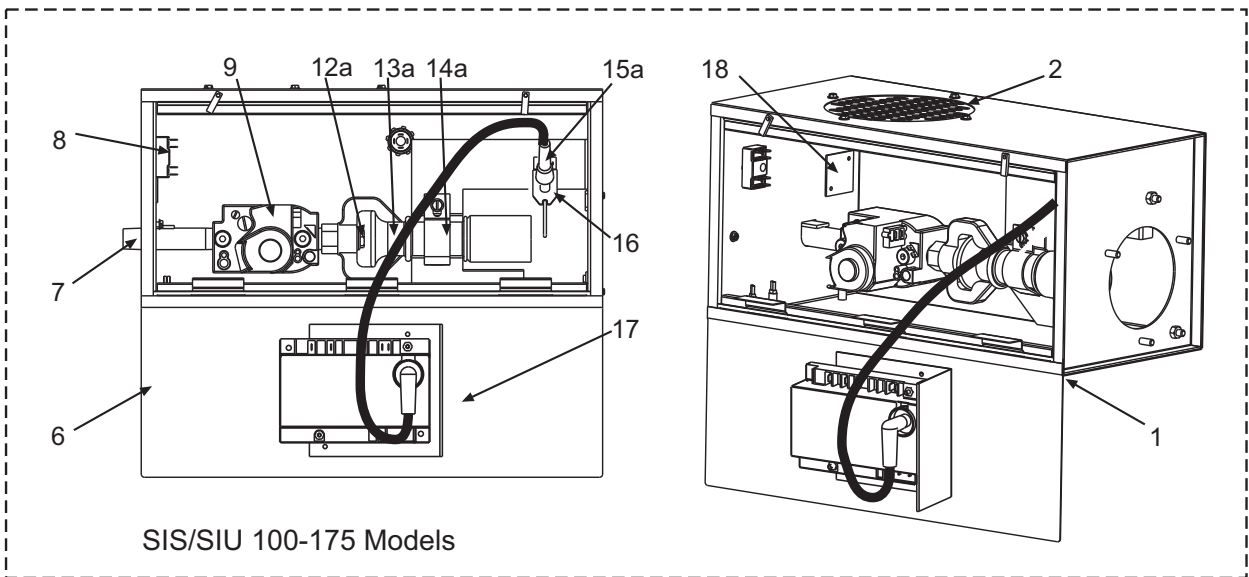

SIS/SIU 100-175 Models

1	Cabinet Assembly	7	Restrainer Nipple	13, 13a	Main Burner
2	Air Inlet Plate	8	Terminal Block	14, 14a	Burner Clamp
3	Sight Glass	9	Gas Valve	15, 15a	Ignition Cable
4	Monitoring Light, Red	10	Nipple	16	Spark Electrode
5	Monitoring Light, Amber	11	Coupling	17	Spark Ignition Module
6	Access Panel	12, 12a	Orifice	18	Sight Glass

NOTE: Access panel only opens to 90°.

22.0) CLEANING AND ANNUAL MAINTENANCE

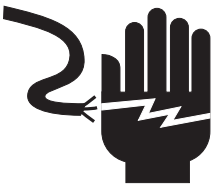
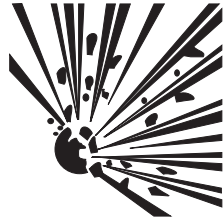
⚠ WARNING		
		ELECTRIC SHOCK & EXPLOSION HAZARD Disconnect electrical power and gas supply before servicing. Failure to do so may result in death or serious injury.

This heater must be cleaned and serviced annually by a qualified contractor before the start of each heating season and at any time excessive accumulation of dust and dirt is observed. Maximum heating efficiency and clean combustion will be maintained by keeping the heater clean.

The contractor shall check the following during periodic maintenance.

- **Clearances to combustibles:** Check that clearances are being maintained. Make sure there are no flammable objects, liquids or vapors near the heater. See also Section 4.0).
- **Reflectors:** Reflectors should be kept clean, at a minimum blow off the reflectors. (Dirty reflectors may reduce heat output).
- **Heat exchanger tubes:** Inspect the heat exchanger tubes to make sure they are not cracked, sagging or showing signs of fatigue.
- **Combustion air intake:** Disconnect combustion air intake from the control box and inspect internally using a flashlight to make sure no foreign material has collected in the tubes and that there is no obstruction around the air intake openings. Clean any foreign materials. Inspect any joints to make sure they are completely sealed. See also Section 18.0).
- **Venting System:** Disconnect vent pipe and inspect internally using a flashlight to make sure no foreign material has collected in the pipes. Check the external vent cap and make sure that there is no obstruction around the exhaust openings. Clean any foreign materials. Inspect any joints to make sure they are completely sealed. See also Section 17.0).
- **Gas lines:** Make sure that the gas lines are not leaking. Check the gas connection to the heater for any signs of damage, fatigue or corrosion. If there are any signs of damage to the gas connection or leaks found in the gas piping, immediately stop using the heater until the gas pipe and connections have been repaired or replaced. Check that the gas lines are not bearing the weight of the heater. See also Section 14.0).
- **Control Box:** In order to extend the longevity of the heater, the heat exchanger tube and the burner must be level. Check that the control box is level; use the turnbuckle on the burner suspension eyebolt to adjust the level of the burner. See also Section 9.0).
- **Blower wheel and housing:** Check that the blower wheel spins freely, blow out any dust or dirt with compressed air.
- **Electrode condition:** Visually check that the electrode gap is maintained at 3/16" and that the tips of the spark electrode are free from deposits. Clean off any deposits. Check that the electrode ceramic is free from cracks. See Section 24.1).
- **Suspension system:** Check that the suspension system is holding the heater level. Make sure that the heater is hanging securely, look for any evidence where the heater may have been hit accidentally and tighten any loose hanging points. Check that S hooks are closed. Check that there is no evidence of wear on the chain at the connection to the heater and at the ceiling.
- **Main Burner and Orifice:** Check the Main burner and orifice; remove any dirt or debris including spider webs. See Section 24.1).

Troubleshooting continued from the previous page.

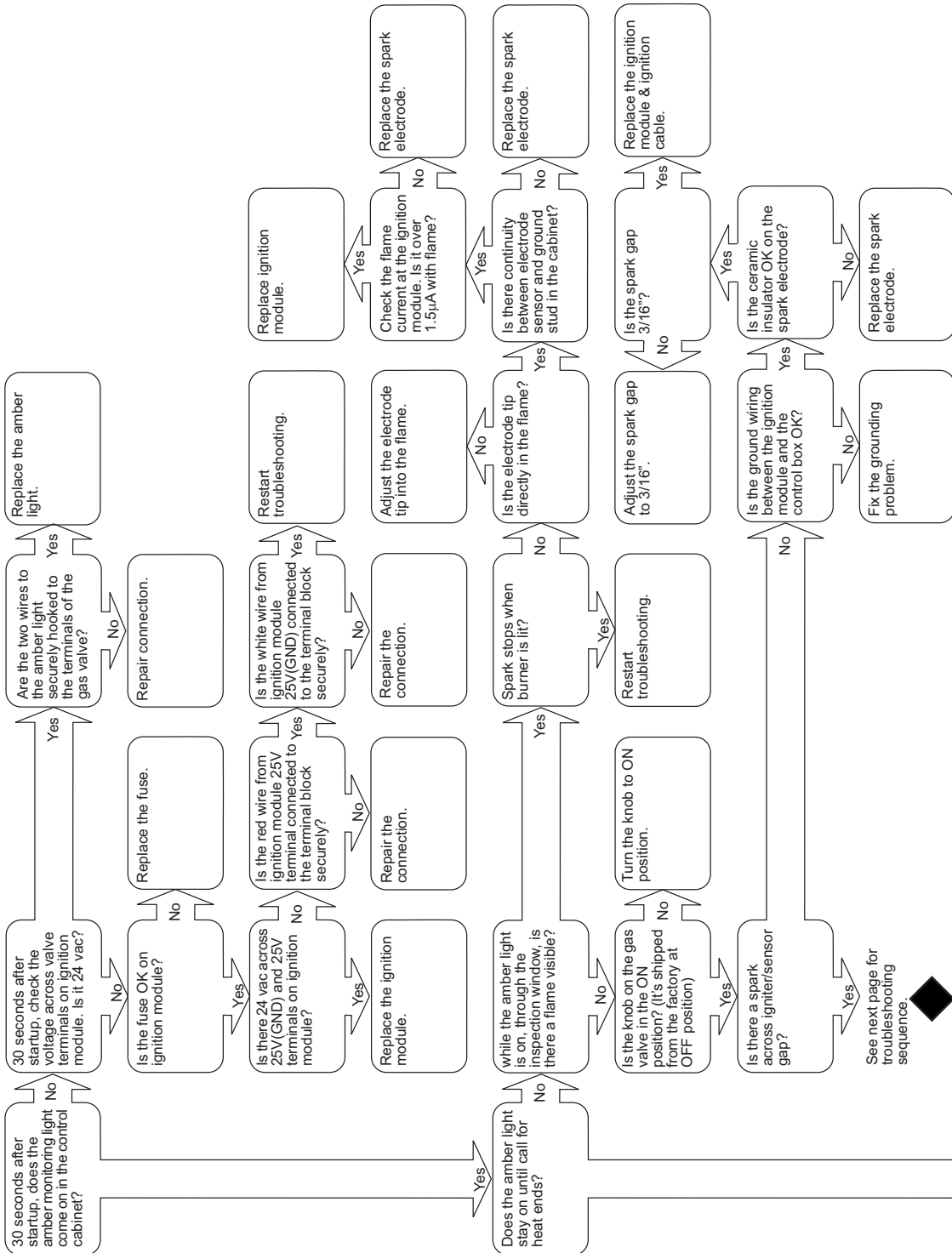

Troubleshooting continued on the next page.

Troubleshooting continued from the previous page.

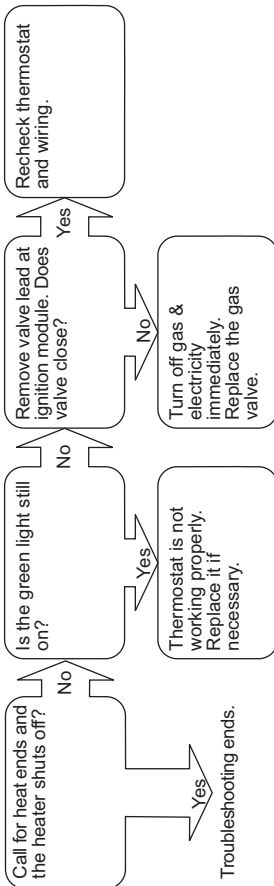

Troubleshooting continued from the previous page.

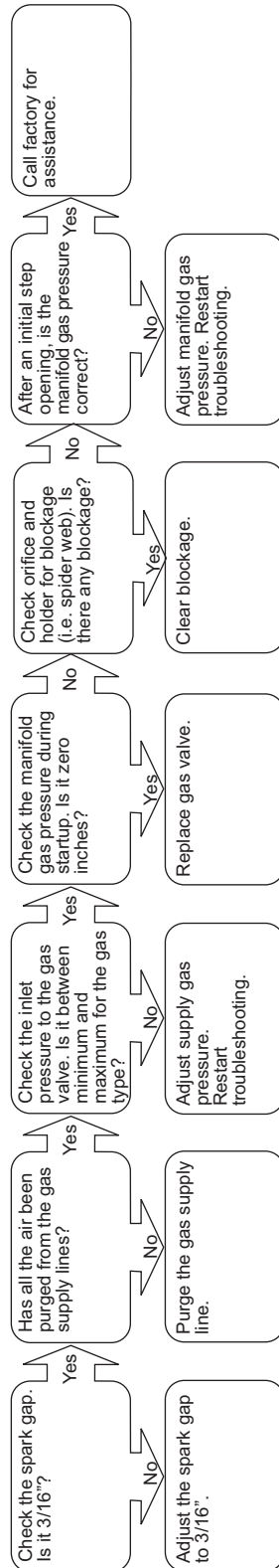

Troubleshooting continued from the page before last.

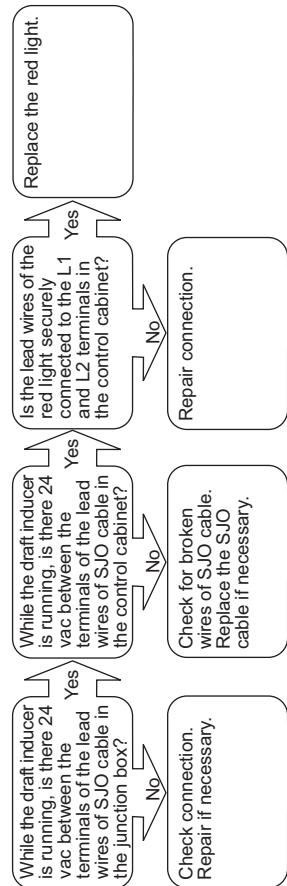

24.0) REPLACING PARTS

⚠ WARNING

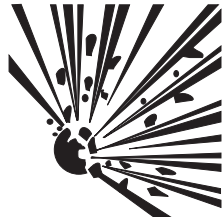
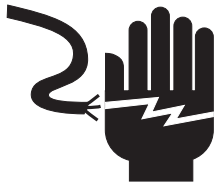

ELECTRIC SHOCK & EXPLOSION HAZARD

Disconnect electrical power and gas supply before servicing.

Failure to do so may result in death or serious injury.

Only use genuine SunStar replacement parts. Parts are available from the factory for replacement by a licensed person. Refer to the Replacement Parts Guide in Section 26.0) for all replacement parts.

24.1) REMOVING SPARK ELECTRODE

The main burner can be inspected without removing the burner housing from the heat exchanger tube.

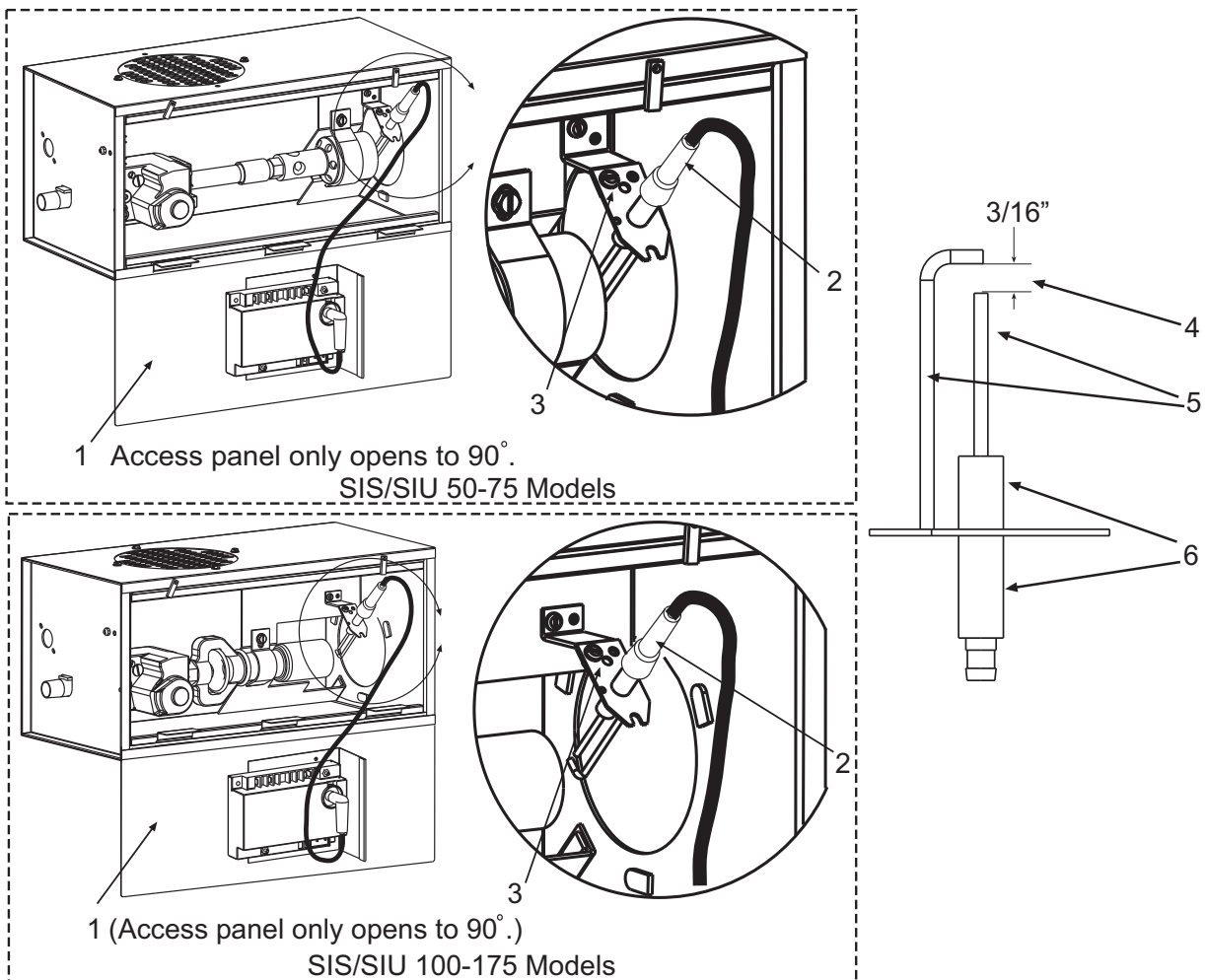

1. Disconnect electrical supply and open access panel.
2. Pull out the ignition cable hooked to spark electrode.
3. Remove two mounting screws.
4. Take out the spark electrode. Check that the spark gap is 3/16".
5. Check spark electrode. Spark electrode should be clean and free from debris.
6. Check ceramic on the spark electrode. It should be free from cracks.

24.2) REMOVING MAIN BURNER AND GAS VALVE

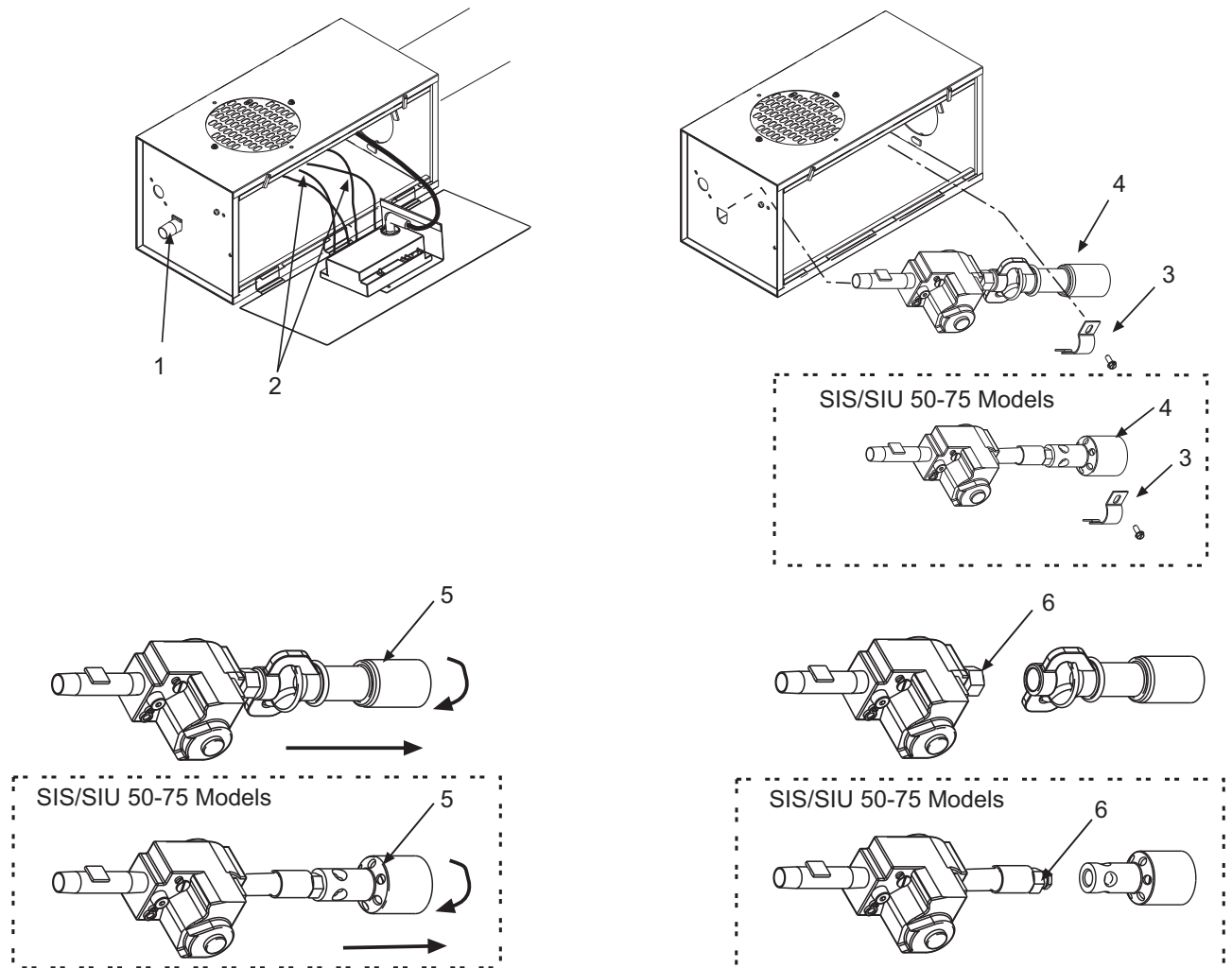

1. Disconnect electrical supply and gas connection at the restrainer nipple.
2. Open the access panel and disconnect the wires from gas valve.
3. Remove the burner clamp and screws.
4. Remove the burner and gas valve assembly from the cabinet.
5. Unscrew the burner from the manifold.
6. Check the orifice. If the gas valve is to be replaced, the pipe joint compounds must be resistant to the action of liquefied petroleum gases.

24.3) AIR SWITCH PRESSURE CHECK

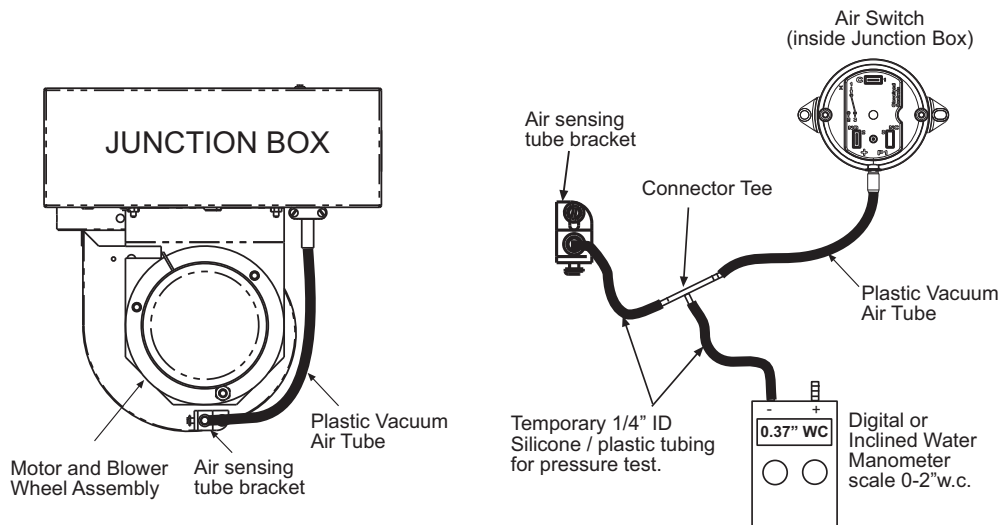

1. Open hinged access panel.
2. Add tubing to connect the air switch with the connector tee and the existing tubing.
3. Connect plastic tubing of a digital or inclined water manometer with a 0-2" scale onto the connector tees.
4. Turn heater on and wait until blower motor is activated.
5. Observe air pressure from manometer. This should be higher than the set point 0.42" W.C. for correct operation.

All pressures are with the heater in operation for at least 15 minutes.

24.4) IGNITION SYSTEM CHECKS

TO CHECK IGNITION CABLE.

- a. Make sure that the ignition cable does not touch any metal surface.
- b. Make sure that connections to the stud terminal and the igniter/sensor are clean and tight.
- c. Make sure that the ignition cable provides good electrical continuity.

TO CHECK IGNITION SYSTEM GROUNDING.

(Nuisance shutdowns are often caused by a poor or erratic ground.) A common ground is required for the module, igniter, flame sensor and main burner.

- a. Check for good metal-to-metal contact between the igniter bracket and the main burner.
- b. Check the ground lead from the GND (BURNER) terminal on the module to the igniter bracket. Make sure connections are clean and tight. If the wire is damaged or deteriorated, replace it.
- c. Replace igniter/sensor with factory replacement part if insulator is cracked.

TO CHECK SPARK IGNITION CIRCUIT.

▲ **WARNING:** The ignition circuit generates a 20,000 Volt open circuit and electrical shock can result.

- a. Check ignition cable.
- b. Check external fuse located inside the draft inducer junction box.
- c. Verify power (24V) at module input terminals and output terminal to gas valve.
- d. Replace spark module if fuse and power are OK.

IGNITION MODULE DIAGNOSTICS (Fenwal #35-6087J1-034 module only)

The **LED** located on the ignition module will flash **ON** for ¼ second, then **OFF** for ¼ second during a fault condition. The pause between fault codes is 3 seconds.

LED Indication	Error Mode
Steady On	Internal Control Fault
2 Flashes	Flame Sense Fault
3 Flashes	Ignition Lockout

TO CHECK FLAME SENSOR CIRCUIT (Fenwal #35-6087J1-034 module only)

The flame current is the current that passes through the flame from the sensor to the ground. The minimum flame current necessary to keep the system from lockout is **0.7 micro-amps**.

- To measure the flame current, connect an analog DC micro-ammeter to the **FC-** and **FC+** terminals per diagram. The meter should read **0.7 micro-amps** or higher when the burner is running full on.
- If the meter reads below **zero**, the meter leads are reversed. Disconnect power and reconnect the meter leads for proper polarity.
- Remove micro-ammeter. Return system to normal operation.

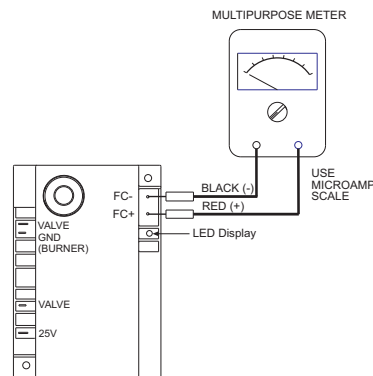

Ignition Module - Alternate
(Fenwal #35-6087J1-034)

24.5) MOTOR AND BLOWER WHEEL CHECK

If draft inducer motor fails to run:

- Check power supply to junction box.
- Check for loose or broken motor lead wire.
- Check to see that blower wheel turns freely and is not rubbing housing. Blower wheel may have worked loose from shaft and jammed against housing.
- Check for blower wheel damage; replace if necessary. If no damage, readjust blower wheel on shaft & retighten set screw.
- If all above does not correct, replace motor.

25.0) INSTALLATION DATA

Date of Installation: _____ # of Heaters in System: _____

Serial No. _____

Model: **SIS or SIU** _____ N = Natural Gas
L = Propane Gas

26.0) REPLACEMENT PARTS GUIDE

DRAFT INDUCER COMPONENTS		
Item No.	Part No.	Description
1	42917000	Draft Inducer Assembly
1a	42928000	Motor Replacement Kit
3	03723000	Blower Wheel, Revcor
4	03988120	Plastic Vacuum Air Tube, 12" long
5	42739010	Blower Housing Sub-Assembly
6	42740000	Motor Plate
7	42742000	Sensing Tube Bracket
8	42744000	Sensing Tube, Draft Inducer
9	30347000	Motor Spacer (4 per motor)
10	03868010	3/8" Connector
11	42837050	Air Switch Kit, set @0.37" W.C., #NS2-0306-00
13	30267000	1/2" Knockout Plug
14	30279000	Transformer
15	30281000	Terminal Block, EK-204
16	30330000	Terminal Block, TFB-323
16a	30202000	Fuse, 2A 250V
17	42709000	Terminal Block Shield
18	42398040	Monitoring Light, Green
19	02175050	Strain Relief
21	42909000	Junction Box
22	42910000	Junction Box Cover
23	42911000	Junction Box Support Bracket
24	42923000	SJO Cable Assembly
25	03721000	Motor
27	43221000	Draft Inducer Gasket
30	42741030	Restrictor Plate, 1-1/8" I.D. (50M Btu/hr)
32	42741010	Restrictor Plate, 1-7/16" I.D. (75M Btu/hr)
34	42741060	Restrictor Plate, 1-5/8" I.D. (100M Btu/hr)
36	42741080	Restrictor Plate, 1-7/8" I.D. (125M Btu/hr)
37	42741090	Restrictor Plate, 2-1/32" I.D. (150M Btu/hr)
38	42741100	Restrictor Plate, 2-1/4" I.D. (175M Btu/hr)
40	40504020	Starting Collar, 4"

Labels / Manual			
Item No.	Part No.	Description	Qty.
41	42874000	Label, Wire Diagram	1
42	42922020	Label, Sidewall Venting	1

DRAFT INDUCER COMPONENTS

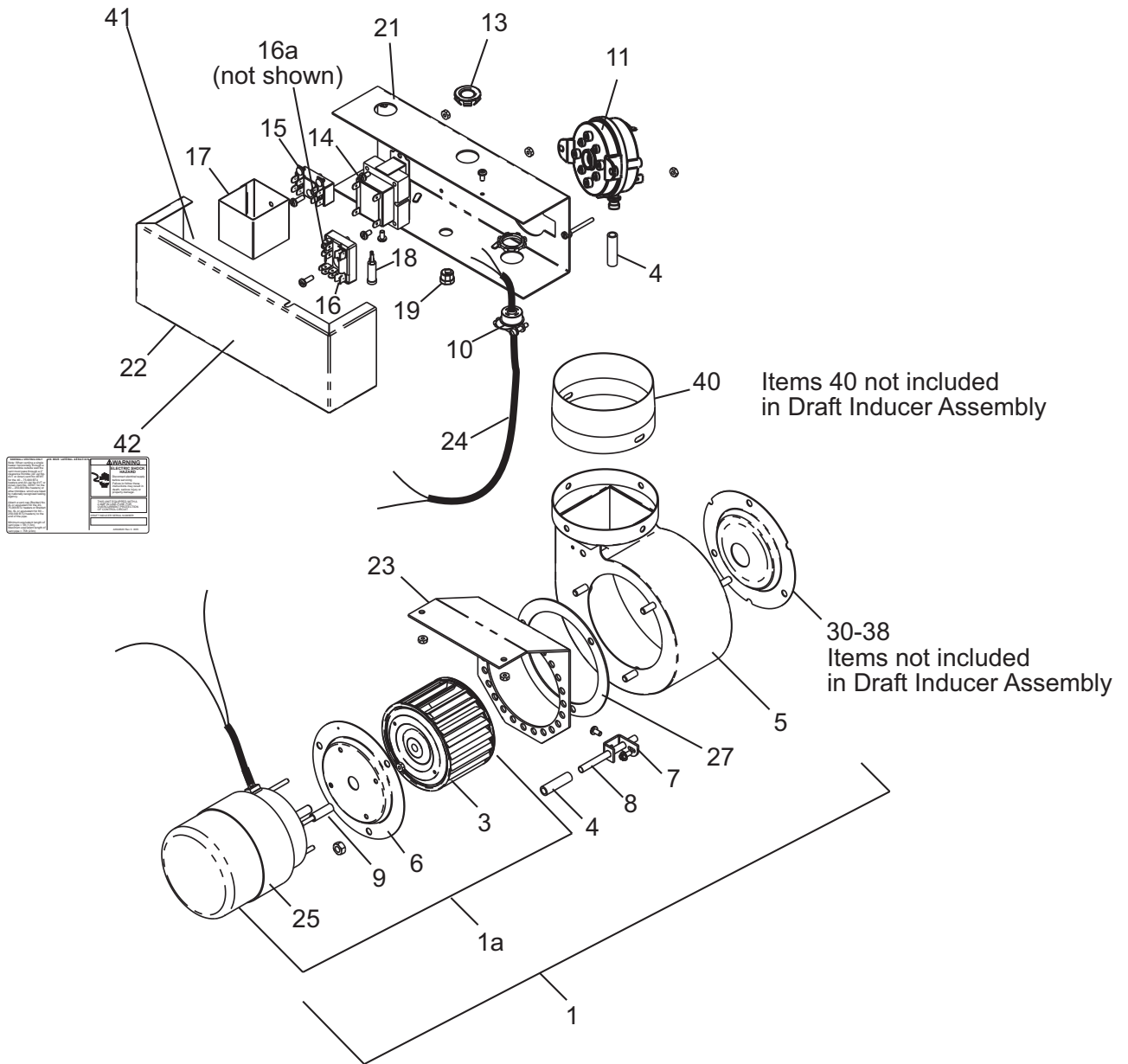
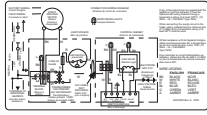

CONTROL COMPONENTS		
Item No.	Part No.	Description
10	03868010	3/8" Connector
28	42874000	Connection Wire Diagram (not shown)
41	30295000	Electrode PSE-GF1 (Igniter/Sensor)
42	30314120	Ignition Cable, 14" long
43	30324000	Terminal Block, EK-104
44	30632060	Spark Module - Fenwal #35-608711-034
45	42398060	Monitoring Light, Red
46	42398050	Monitoring Light, Amber
47	42447000	Sight Glass
51	30333070	Valve, VR8205P-2408 @3.5" W.C. (Natural Gas)
52	30333080	Valve, VR8205P-2416 @10" W.C. (Propane Gas)
53	42757010	Restrainer Nipple, 4" long
54	42885000	Spark Module Shield
55	42887100	Burner Clamp
56	42890010	Burner Assembly
57	42899100	Burner Bracket Sub-Assembly
58	42888000	Electrode Bracket
59	42893000	Air Inlet Plate (Perforated)
60	42905000	Access Panel
61	42906100	Cabinet Assembly (for offset burner)
62	42889000	Orifice Fitting & Test Gauge Connection
63	03258xxx	Orifice for 100M-175M Btu/hr (State Model & Gas Type for Size)
67	03540090	Coupling, 1/2"
68	42701000	Orifice Fitting & Test Gauge Connection
69	03259xxx	Orifice for 50M-75M Btu/hr (State Model & Gas Type for Size)
70	42700000	Burner
71	43169000	Burner Clamp
72	43172100	Burner Bracket Sub-assembly
73	43170000	Electrode Bracket
74	03333140	Nipple, 1/2"x4" long

Labels / Manual			
Item No.	Part No.	Description	Qty.
64	43343310	Installation and Operation Instructions (not shown)	1
75	42785000	Label, Wire Diagram (ladder)	1
76	42874000	Label, Wire Diagram	1
77	42875000	Label, Warning	1
78	43269000	Label, 24V Supply	1
79	43270000	Label, Terminal ID	1
80	42013010	Label, "SunStar" Logo	1
81	42848010	Label, "SunStar" Nameplate	1
82	43344010	Label, Clearance to Combustibles	1
83	43344050	Label, Gas Connector Warning	1

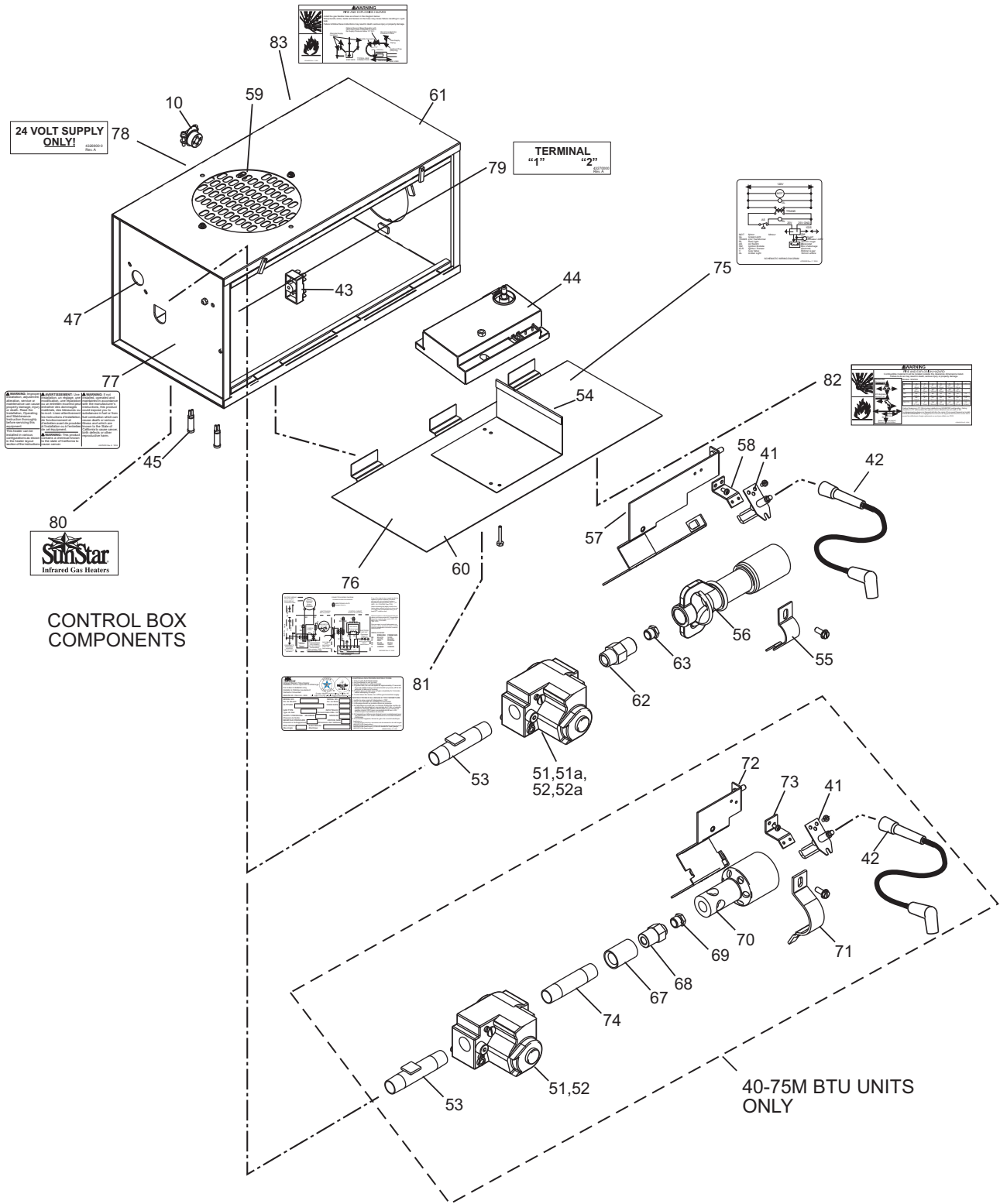

BODY COMPONENTS: SIS/U 50-175			
Item No.	Part No.	Description	
1	02266010	Reflector Speed Clip	
2	43980010	Wire Hanger	
3	42873000	"U" Bolt Clamp, 4" OD Tube	
3a	02127110	5/16-18 Hex Nut (2 per "U" Bolt)	
4	43318000	Tube Support/Hanger Bracket, 13"	
5	43319050	Reflector, 4'-11½" long (5' section only; 1 per 5 ft. body section)	
6	43319100	Reflector, 9'-11½" long (10' section only; 1 per 10 ft. body section)	
7	43320000	End Reflector	
8	43342000	Corner Reflector Package	
9	42921000	Tube Flange Gasket	
10*	44028250	10' Tube Assembly Kit, 4" OD, ALC steel with one 12-radial hole flange (start tube)	
11	44028100	10' Tube Assembly Kit, 4" OD, HR steel without flanges (extension tube & exhaust tube)	
12	44028120	5' Tube Assembly Kit, 4" OD, HR steel without flanges (extension tube & exhaust tube)	
13	43208010	4" O.D. Elbow Package	
14	02189020	#10 x ½" Self-Drilling Screw (2 per coupling)	
15	30462980	4" OD Tube Compression Coupling w/bolts	
16	43208020	4" OD U-Bend (Required for SIU Only)	ALC = Heat Treated, Aluminized Steel HR = Hot Rolled Steel
17	43488000	U-Bend Reflector (SIU Option)	
18	44015251	Tube Flange Assembly (with 1/4-20 x 1" screw)	
* Required on all models for mounting of control box.			

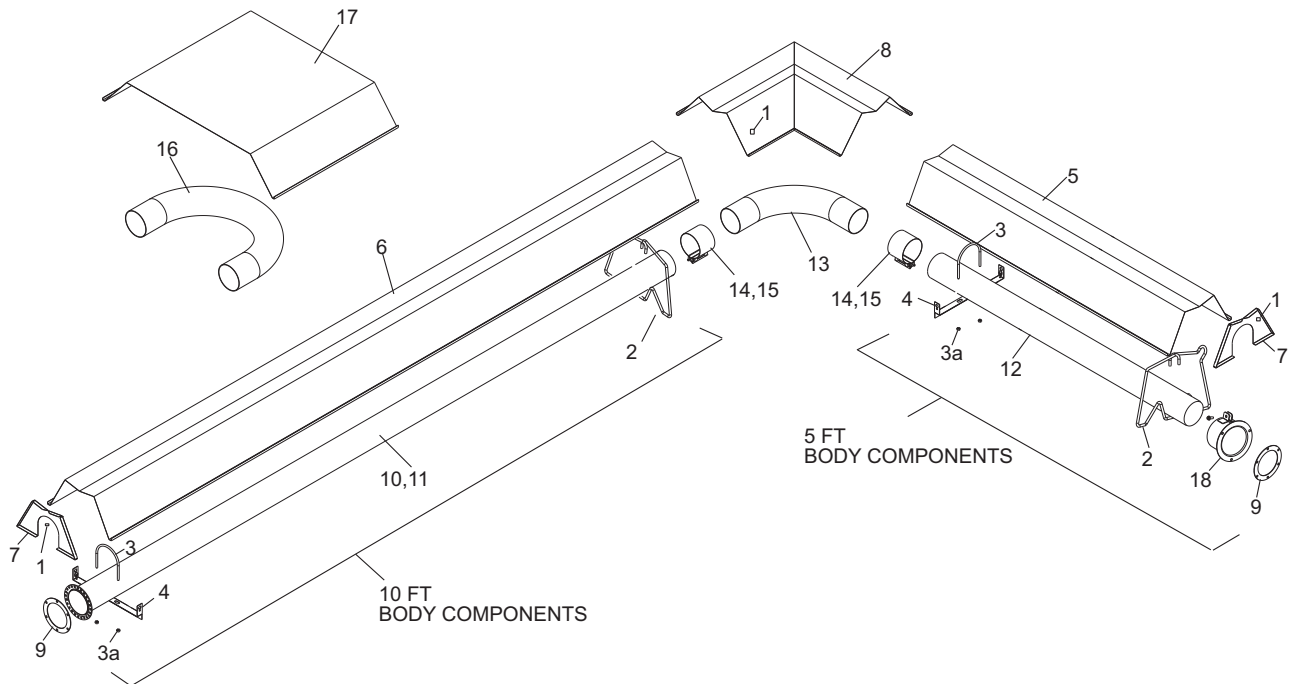

Note:

- 1) Screws, Nuts and Washers are standard hardware items and can be purchased at any local hardware store.
- 2) Please order by PART NUMBER – not by Item Number.
- 3) Replacement Part Prices are available when ordering.
- 4) Please refer to complete Model Number when ordering.

ALL ILLUSTRATIONS ARE INTENDED TO GIVE THE GENERAL IMPRESSION OF UNITS ONLY. OTHER COMBINATIONS OF 5 FT. AND 10 FT. SECTIONS, AND ONES WITH OR WITHOUT THE ELBOW PACKAGE ARE POSSIBLE. PLEASE CONSULT WITH YOUR SUNSTAR SALES REPRESENTATIVE. WE RESERVE THE RIGHT TO ALTER ANY SPECIFICATION WITHOUT NOTICE.

27.0) WARNINGS CARD

Copies of this card may be ordered at no charge under part no. 43344980 for installation near the heater.

- Attach this information card adjacent to the thermostat which controls the SunStar heater(s). ○



Read the Installation and Operating Instructions thoroughly before installation, operation or service.

INSTALLER: Write the clearance distance for the highest BTU model in the building in the blank spaces below using permanent ink. The clearances to combustible materials are based on each individual heater model number. Locate the heater model number on the nameplate affixed to the heater. The clearances to combustibles distances can be located adjacent to the nameplate or in the Installation & Operating (I & O) Instructions. I & O's can also be located on www.spaceray.com

WARNING



FIRE HAZARD

Combustible material must be located outside the clearance distance listed from heater.

Some objects will catch fire or explode when placed close to heater.

Failure to follow these instructions can result in death, injury or property damage.

Maintain Clearances to Combustibles to Prevent the Risk of Fire.

Clearance to combustibles must be maintained at all times in order to prevent the ignition of combustible materials. In locations used for the storage of combustible materials signs must be posted to specify the maximum permissible stacking height to maintain the required clearances from the heater to the combustibles. Signs must either be posted adjacent to the heater's thermostats or in the absence of such thermostats, in a conspicuous location.

**Maintain the following clearances:
_____ to the side, _____ above
and _____ below the heater
from combustible materials.**

IF YOU SMELL GAS:

FOR YOUR SAFETY

! **DO NOT** try to light any appliance.
! **DO NOT** touch any electrical switch; **DO NOT** use any telephone in your building.
! **IMMEDIATELY** call your gas supplier from a neighbor's telephone. Follow the gas supplier's instructions.
If you cannot reach your gas supplier, call the fire department.

Installation Code and Annual Inspections:

Installation and Service of SunStar equipment must be performed by a qualified contractor and conform with all requirements set forth in the SunStar Installation and Operating Instructions and any National and Local codes pertaining to the installation, service and operation of the equipment. Annual inspection is recommended prior to the heating season to ensure proper operation of the heating equipment.

SUNSTAR HEATING PRODUCTS, INC.
Post Office Box 36271 (28236) * 306 West Tremont Avenue (28203) * Charlotte, North Carolina
Phone (704) 372-3486 * Fax (704) 332-5843 www.sunstarheaters.com * email: info@sunstarheaters.com

43344980
July 2012