



ClearSpan™ Electric Roll-Up Room Divider Installation Guide



Actual room divider may differ from the example shown above.

©2009 ClearSpan™
All Rights Reserved. Reproduction
is prohibited without permission.

Revision date: 09.02.09

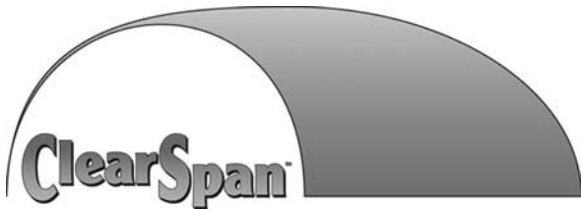

READ THIS DOCUMENT BEFORE YOU BEGIN!

Thank you for purchasing our ClearSpan™ Electric Roll-Up Room Divider. This guide includes helpful hints and important information needed to safely attach and properly maintain your room divider components. Please read these instructions **before** you begin.

If you have any questions during the assembly, contact customer service for assistance.

SAFETY PRECAUTIONS

- Wear eye and head protection.
- Wear gloves when handling metal components.
- Use a portable GFCI (Ground Fault Circuit Interrupter) when working with power tools and cords.

⚠ WARNING: The individuals assembling this room divider are responsible for designing and furnishing all temporary bracing and support needed during the assembly process. For safety reasons, those who are not familiar with recognized construction methods and techniques must seek the help of a qualified contractor.

CONNECTING THE ELECTRIC MOTOR TO THE ELECTRICAL SYSTEM MUST BE COMPLETED BY A QUALIFIED ELECTRICIAN.

UNPACK AND IDENTIFY PARTS

The following steps will ensure that you have all the necessary parts before you begin to install the room divider.

1. Unpack the contents of the shipment and place where you can easily inventory the parts. Refer to the Bill of Materials/Spec Sheets.
2. Verify that all parts listed on the Bill of Materials/Spec Sheets are present. If anything is missing or you have questions, consult the Pictorial Parts Guide and all diagrams for clarification, or contact Customer Service.

NOTE: At this time, you do not need to open the plastic bags containing smaller parts such as fasteners or washers.

ASSEMBLY PROCEDURE

Following the instructions as presented will help ensure the proper installation of your room divider. Failing to follow these steps may result in an improperly assembled room divider and may void all warranty and protection offered to the customer/owner.

The steps outlining the assembly process are as follows:

1. Verify that all parts are included in the shipment. Notify Customer Service for questions or concerns.
2. Read these instructions and additional documentation (if any) included with the shipment **before** you begin.
3. Gather the tools, bracing, ladders (and lifts), and assistants needed to install the room divider.
4. Verify that the panel covers the opening as desired.
5. Determine where and how to attach the room divider panel and motor. Consult this guide for examples.
6. Read the care and maintenance information listed below.
7. Complete and return all warranty information and documentation as instructed (if present).

CARE AND MAINTENANCE

Proper care and maintenance of your ClearSpan™ Electric Roll-Up Room Divider and its components is important. Check the following items periodically to properly and adequately maintain your product:

- Regularly check the room divider to see that it remains tight and in proper repair.
- Verify that nothing interferes with the operation of the panel as it is rolled up and down. Do not allow the contents of the rooms to touch or rub against any of the roll-up room divider components.
- Verify that all customer-supplied fasteners remain tight and in good condition. Replace or tighten immediately if these break or loosen.
- *Frequently check all components. Replace worn or damaged parts immediately.*
- Inspect the electrical connections and supply wiring to ensure these are in good condition. Consult the services of a qualified electrician if needed.
- Use tools that will not damage the room divider when removing debris and during cleaning.



The following graphics and photos shown below are used in a typical room divider installation. (Some parts are not shown.)

REQUIRED TOOLS

The following list identifies the main tools needed to assemble and install the room divider.



Additional tools and supports may be needed depending on the structure, location, and room divider size and design.

- Tape measure or measuring device
- Variable speed drill and impact driver (cordless with extra batteries works best)
- Scissors or utility knife to cut strap
- Hammers, gloves, and head and eye protection
- Ladders, work platforms, and other machinery for lifting designed to work safely at the height of the opening.

ATTENTION: Consult the services of a qualified, professional contractor if you are not familiar with the installation of similar systems and components.



10016608
1-1/2" Rail Bracket



CC6212
Fabric Clip



WF1981
1-1/4" x 1-1/4" PVC Coupling



Tek Screw

1.315" Swaged Pipe
(Insert in panel pocket.)

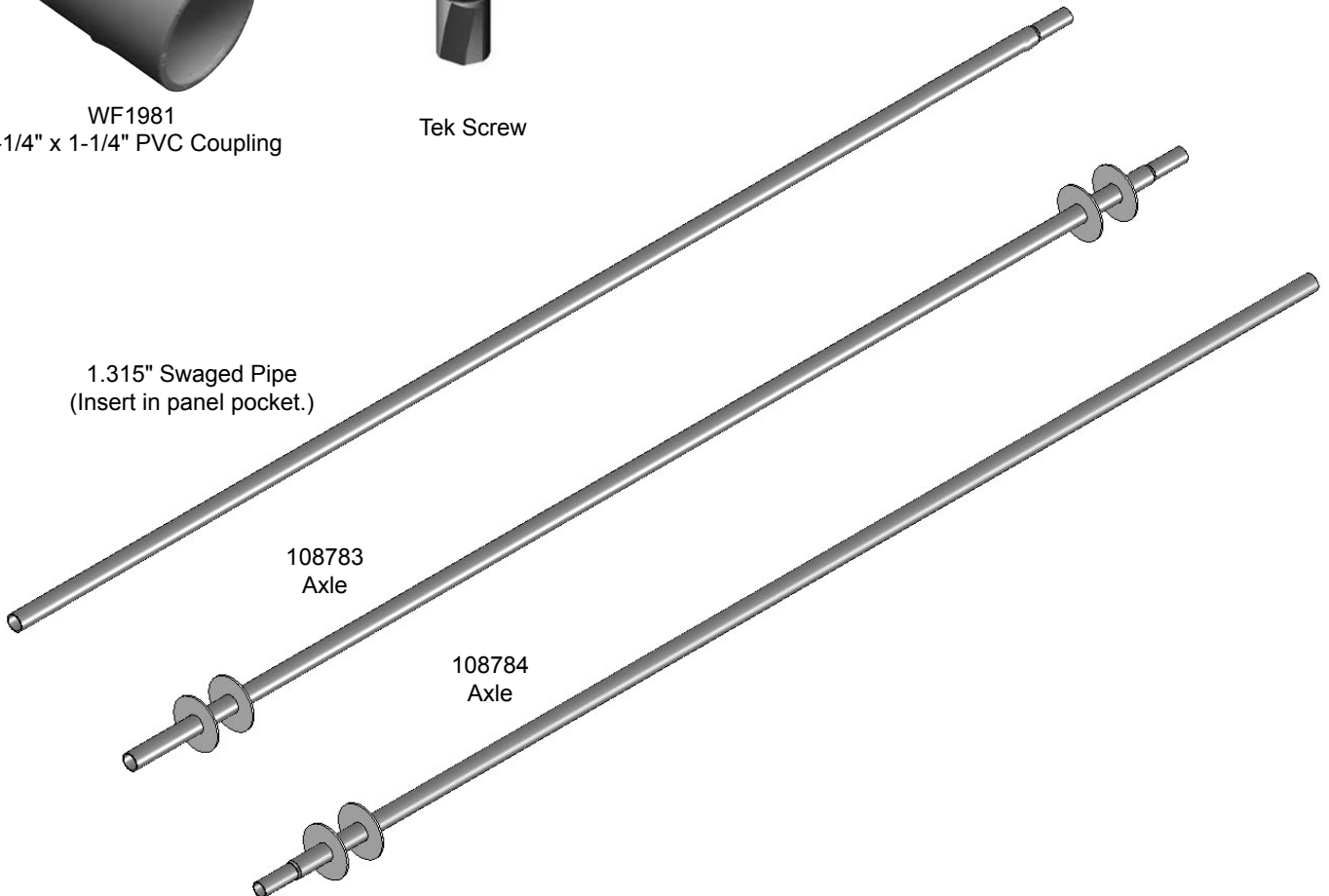

108783
Axle

108784
Axle



Actual panel may differ from what is shown above.

Electric Roll-Up Room Divider

ATTENTION: Customer is responsible for determining the best way to attach the divider components to the building or mounting surface. ***Purchase dimensional lumber (if needed) and the correct fasteners locally.***

OVERVIEW

This section describes the basic installation steps for the electric roll-up room divider.

1. Locate the required parts for each procedure.
2. Verify that the panel covers the opening as desired.
3. Determine where to mount the electric drive motor.
4. Prepare the mounting surface.
5. Attach motor, drive axles, and room divider panel to mounting surface.
6. Install straps and test the roll-up room divider.

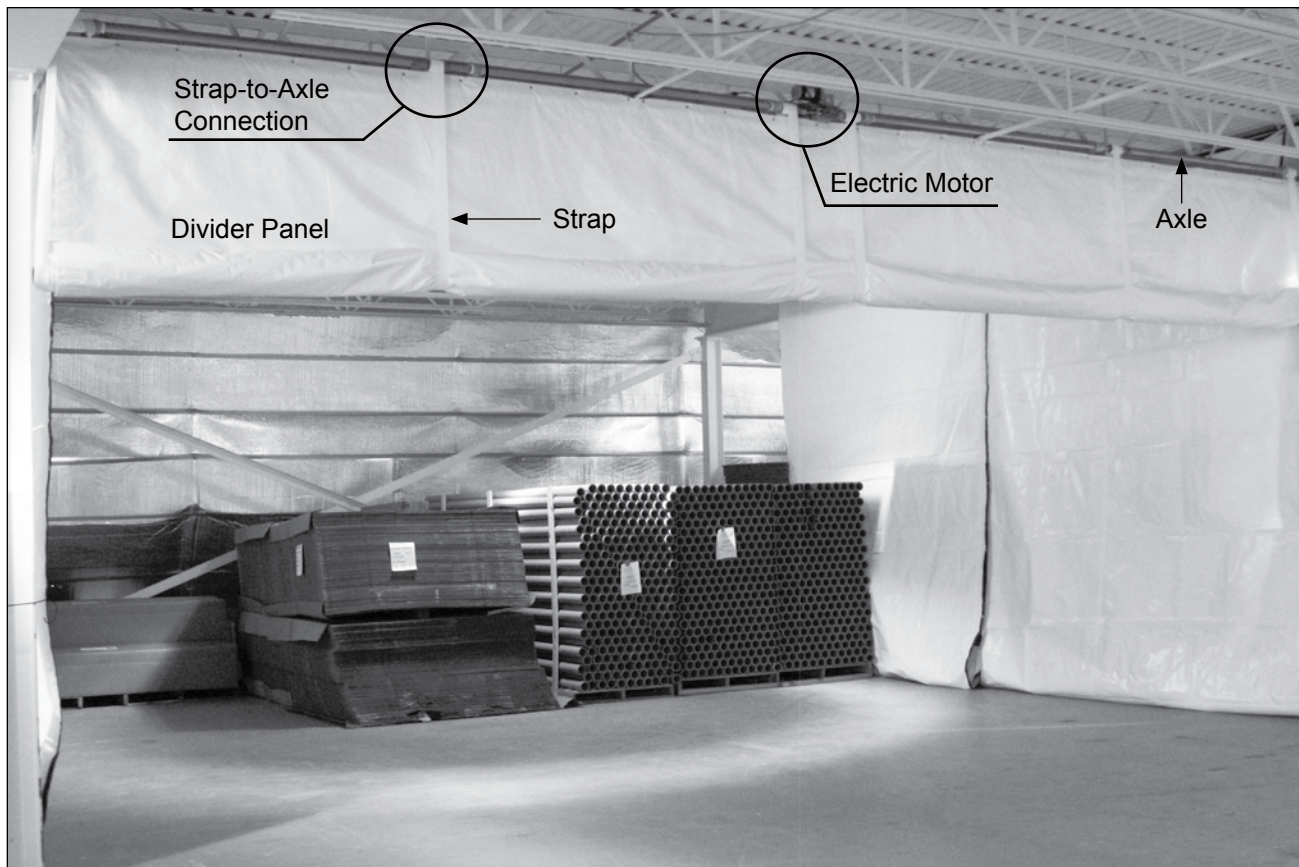

1

MOUNTING SURFACE

Several factors affect the way to properly secure the electric room divider. Building frame and available materials must be considered. *Lumber and fasteners are not included and can be purchased locally.*

Consult the example below for a suggested method. If the suggestions do not apply to your building, consult a qualified professional experienced with similar installations and dividers, or call your sales representative for additional information.

Photos show an installed room divider. Divider shown is used as an example only. It may or may not apply to your specific needs.

Example: Determine where you want to install the room divider. Divider components can be mounted to steel support beams as shown or to a wood structure.

Customer-supplied fasteners must be able to support the weight of the divider panel, motor, and all drive components. Fasteners must also withstand the forces generated when operating the roll-up room divider.



In the example above, dimension lumber has been bolted to the steel support beams of an industrial building. Divider components are then secured to the wooden mounting surface as shown below.



2

INSTALL DIVIDER PANEL AND CONDUIT

Before hanging the divider panel, roll it out on a clean surface and measure to ensure that it will cover the opening as planned. Position the edge of the panel with grommets at the top of the framed opening. Once the room divider panel dimensions are verified, continue with the steps that follow.

OPTION #1: Panel Installed Before Drive Unit

If the mounting surface is narrow, or panel is unable to be attached to the backside of the framed opening, it may be best to install the room divider panel *before* mounting the motor and drive axles. Review the following information and diagrams to determine if this option describes the best way to continue.

With assistance and lifts or ladders, center the room divider panel within the opening. Lift the room divider panel up to the mounting surface and secure the center of the panel to the mounting surface using customer-supplied fasteners. Working from the center in both directions, stretch panel evenly and verify that it is centered and level. **Lower edge of the room divider panel must remain on the ground.**

Secure panel to the mounting surface using customer-supplied fasteners as shown in the diagram below.

With the panel in position and attached, assemble the conduit for the room divider panel.

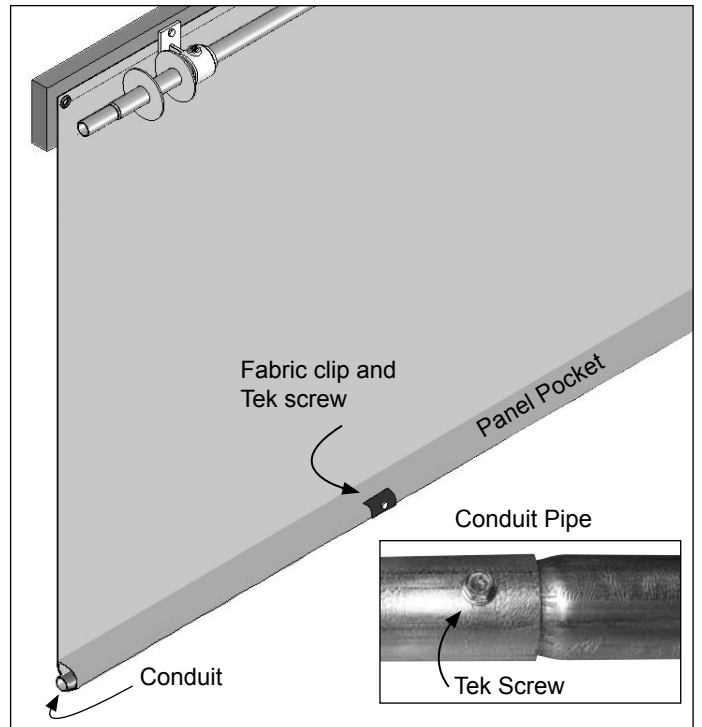

Begin with one (1) 1.315" swaged pipe, slide the plain end into the panel pocket, and continue adding swaged pipes to arrive at the length needed to reach the end of the panel. Secure each pipe joint with a Tek screw and wrap the screw and joint with duct tape. *Cut the last pipe to match the length of the roll-up room divider.*

With the assembled conduit inside the panel pocket, secure it to the panel using Tek screws and fabric clips. Evenly space the clips along the entire length of the panel.

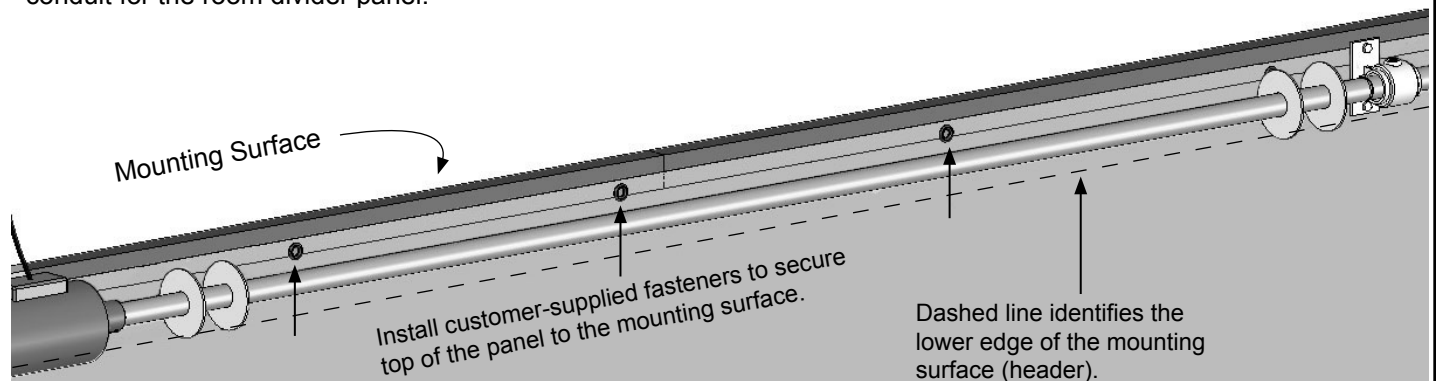

This diagram shows the motor and axle mounting brackets installed over the panel. In this example, the mounting surface dimensions required the installation of the panel and then the installation of the motor and axles. See the next page for another installation example. Install straps last.

2

INSTALL DIVIDER PANEL AND CONDUIT (continued)

Once the panel dimensions are verified, continue with the steps that follow.

OPTION #2: Panel Installed After Drive Unit

If the mounting surface is wide enough, the divider panel can be installed after mounting the motor and drive axles. Review the following information to determine if this option is the best way to continue. If this option applies, install the panel now, or continue with the installation of the drive components. Once those are installed, return to this option and install the panel as described below.

With assistance and lifts or ladders, center the room divider panel within the opening. Lift the panel up to the mounting surface and secure the center of the panel to the mounting surface using customer-supplied fasteners. Working from the center in both directions, stretch panel evenly and verify that it is centered and level. **Lower edge of the room divider panel must remain on the ground.**

Secure panel to the mounting surface using customer-supplied fasteners as shown in the diagram below.

With the panel in position and attached, assemble the conduit for the roll-up room divider.

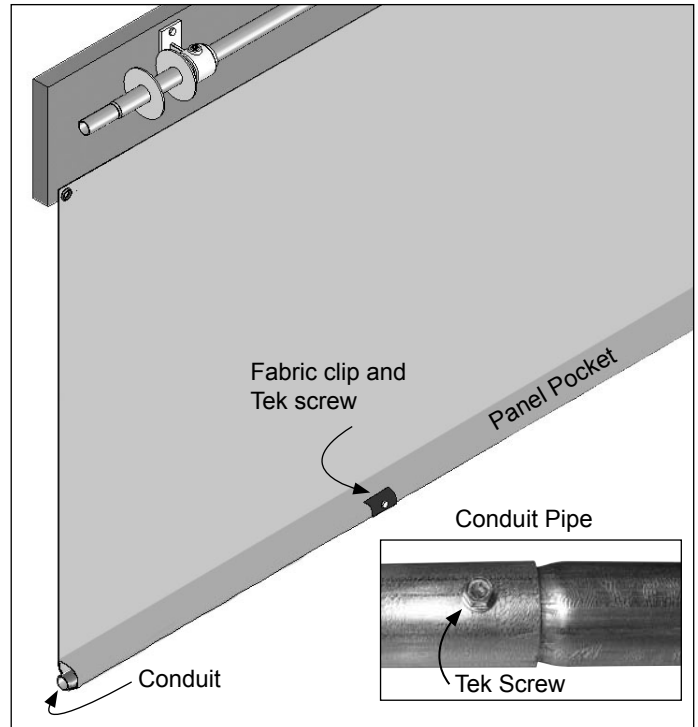

Begin with one (1) 1.315" swaged pipe, slide the plain end into the panel pocket, and continue adding swaged pipes to arrive at the length needed to reach from end to end. Secure each pipe joint with a Tek screw and wrap the screw and joint with duct tape. *Cut the last pipe to match the room divider panel length.*

With the assembled conduit inside the panel pocket, secure it to the panel using Tek screws and fabric clips. Evenly space the clips along the entire length of the panel.

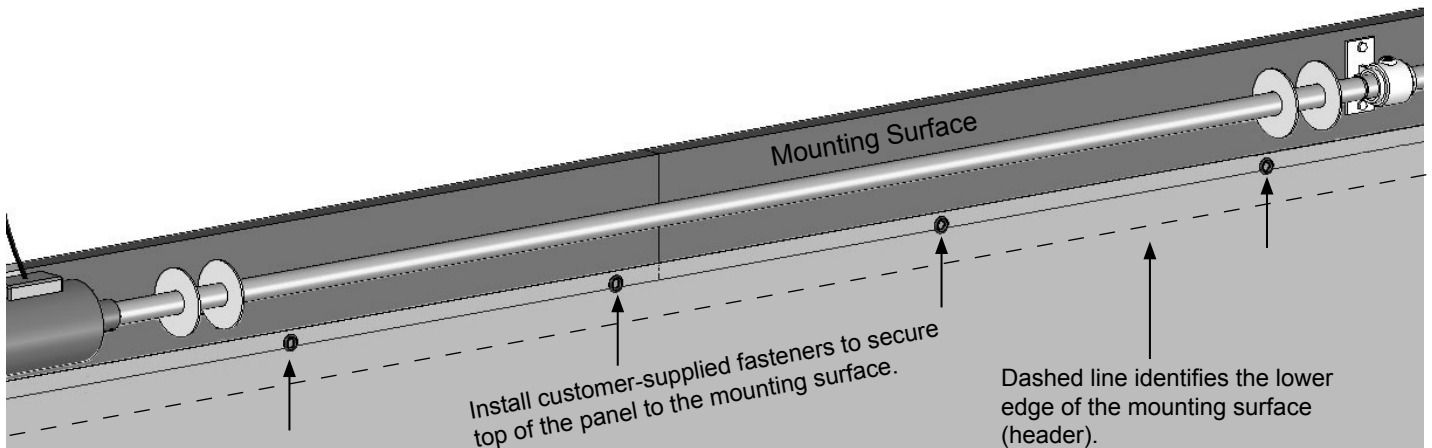

This diagram shows the motor and axle mounting brackets installed above the top edge of the panel. In this example the mounting surface was wide enough to first attach the motor and axles and then install the panel. Install straps last.

3

ASSEMBLE ROLL-UP DRIVE UNIT

When installing the roll-up drive unit, verify the clearances needed for the room divider to work properly. Adjust as needed. Measure the divider panel and related components to accurately position the motor.

With assistance, attach electric motor to the mounting surface using customer-supplied fasteners.

Attach the plain end of the 108783 drive axle to the electric motor using customer-supplied fasteners.

Verify that the axle is level and attach mounting bracket to the mounting surface as shown below.

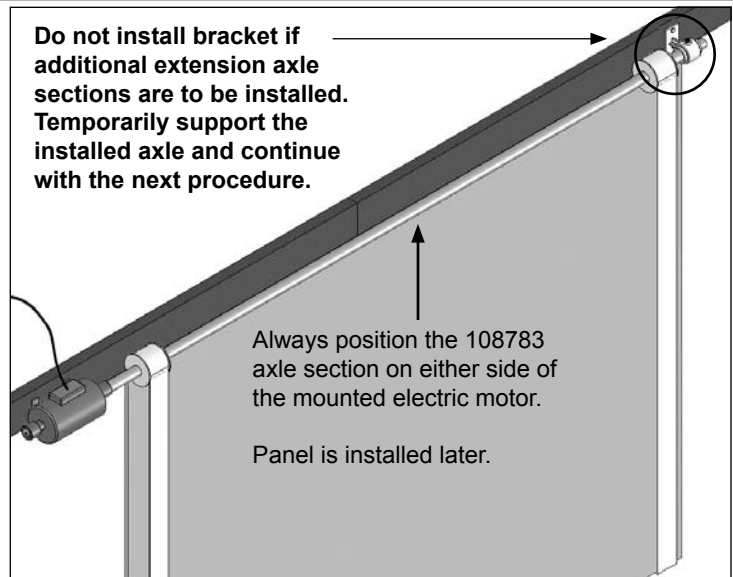

Drawing shows an eight (8') foot panel with electric motor. Panel and strap are installed later in these instructions.

STEP 1: Mount motor and connect the 108783 axle.

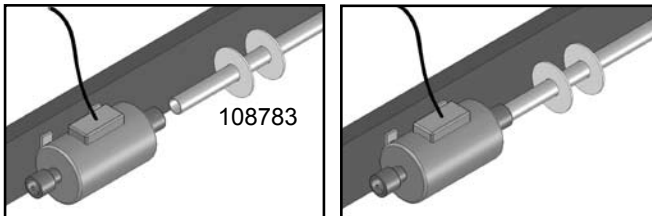

Attach the plain end of the 108783 axle to the motor.

STEP 2:

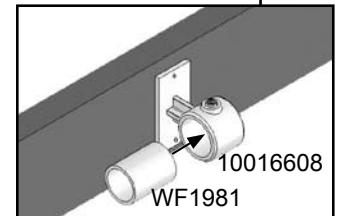

Slide the WF1981 bushing into the 10016608 mounting bracket and slightly tighten the hex locking screw using an Allen (hex key) wrench.

Do not overtighten the set screw. Doing so will distort the bushing and may cause the axle to bind inside the bushing.

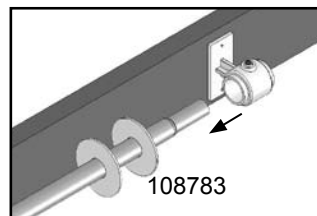

Slide assembled mounting bracket and bushing onto the end of the axle.

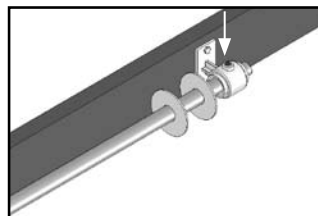

Level the axle and secure the bracket assembly to the mounting surface.

ATTENTION: If additional 8' axle extension sections are to be installed, do not attach the bracket and bushing assembly at this time. Temporarily support the axle and continue with the instructions on the following pages.

4

8' EXTENSION AXLE INSTALLATION: OPTION 1

After attaching the base roll-up drive unit and temporarily supporting the loose end, install the extension axle.

The extension axle can be attached to the free end of the base roll-up drive as shown below, or attached directly to the motor as shown on the following page.

Level all extension axles to ensure proper operation.

ATTENTION: In some instances, it may be necessary to shorten an extension axle so that the width of the assembled drive components—the motor and axles—spans the opening as desired. To shorten a 108784 drive axle, cut the axle to the desired length. Do not cut the swaged/tapered end. *Cut only the plain end of the pipe.* Then connect to the drive assembly as needed.

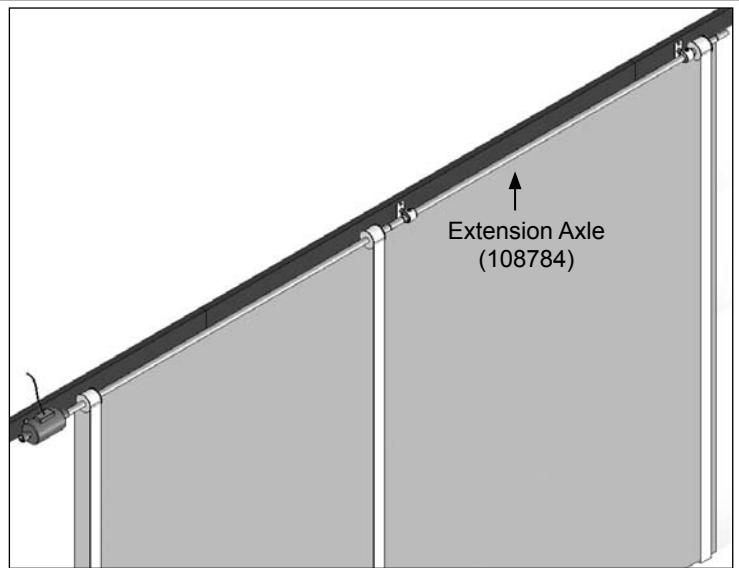

Drawing shows the extension axle attached at the end of the assembly. Panel and strap are installed later in these instructions.

STEP 1: Slide two (2) bracket and bushing assemblies onto the 108784 extension. Attach the 8' extension axle to the axle connected to the drive motor. With assistance, adjust to level the axles and secure the brackets to the mounting surface.

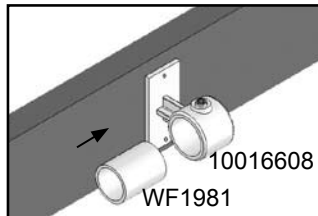

Assemble brackets and bushings.

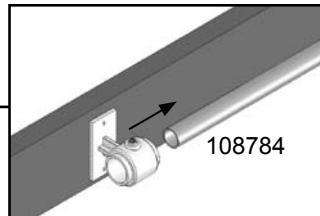

Slide two assemblies onto the 108784 axle.

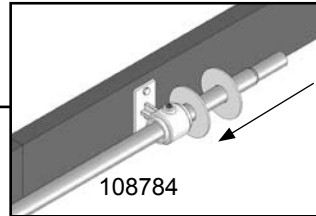

Slide axle and brackets to attach to 108783 axle.

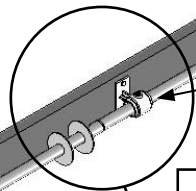

If the 10016608 bracket was installed earlier with the base drive assembly, remove and reposition as shown below.

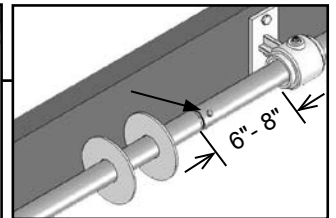
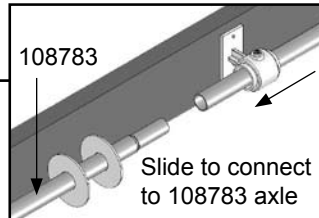

Mount the bracket 6" to 8" from the pipe splice. Secure the axle-to-axle splice using a Tek screw. Verify that the Tek screw does not contact any part of the bracket.

Pipe Joint

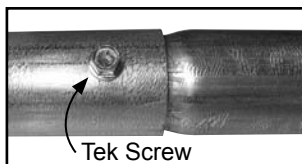

4

8' EXTENSION AXLE INSTALLATION (continued): OPTION 2

After attaching the base roll-up drive unit, an 8' extension axle can be installed opposite the main drive axle. This 8' extension axle (108784) is attached directly to the motor as shown below.

Level all extension axles to ensure proper operation.

CONNECTING THE ELECTRIC MOTOR TO THE ELECTRICAL SYSTEM MUST BE COMPLETED BY A QUALIFIED ELECTRICIAN.

Drive motor is installed at or near the center of the opening/panel.

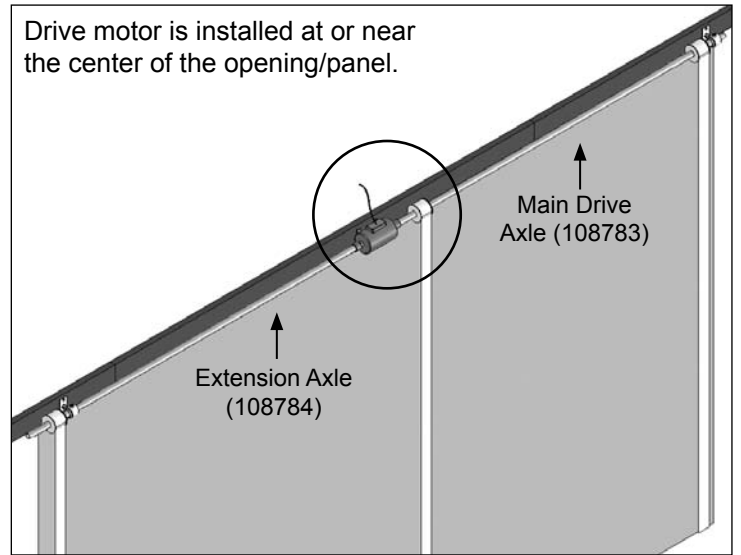

Drawing shows the extension axle attached directly to the drive motor, which is centered in the opening. Panel and strap are installed later.

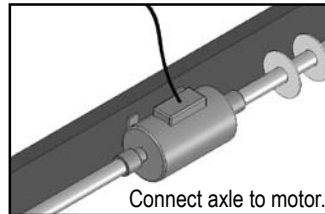
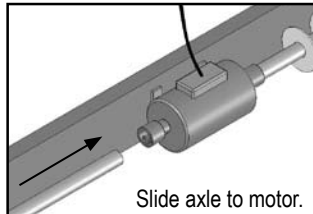
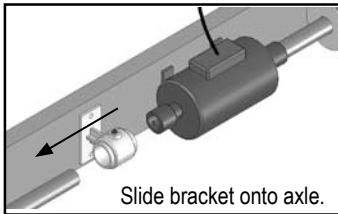

Prepare the mounting bracket as described in Section 3, then slide the mounting bracket assembly over the plain end of the 108784 axle. With assistance, attach the plain end of the 108784 extension axle to the motor. Verify that the axle is level and secure the mounting bracket to the mounting surface using customer-supplied fasteners.

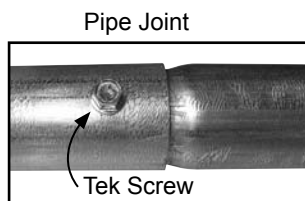
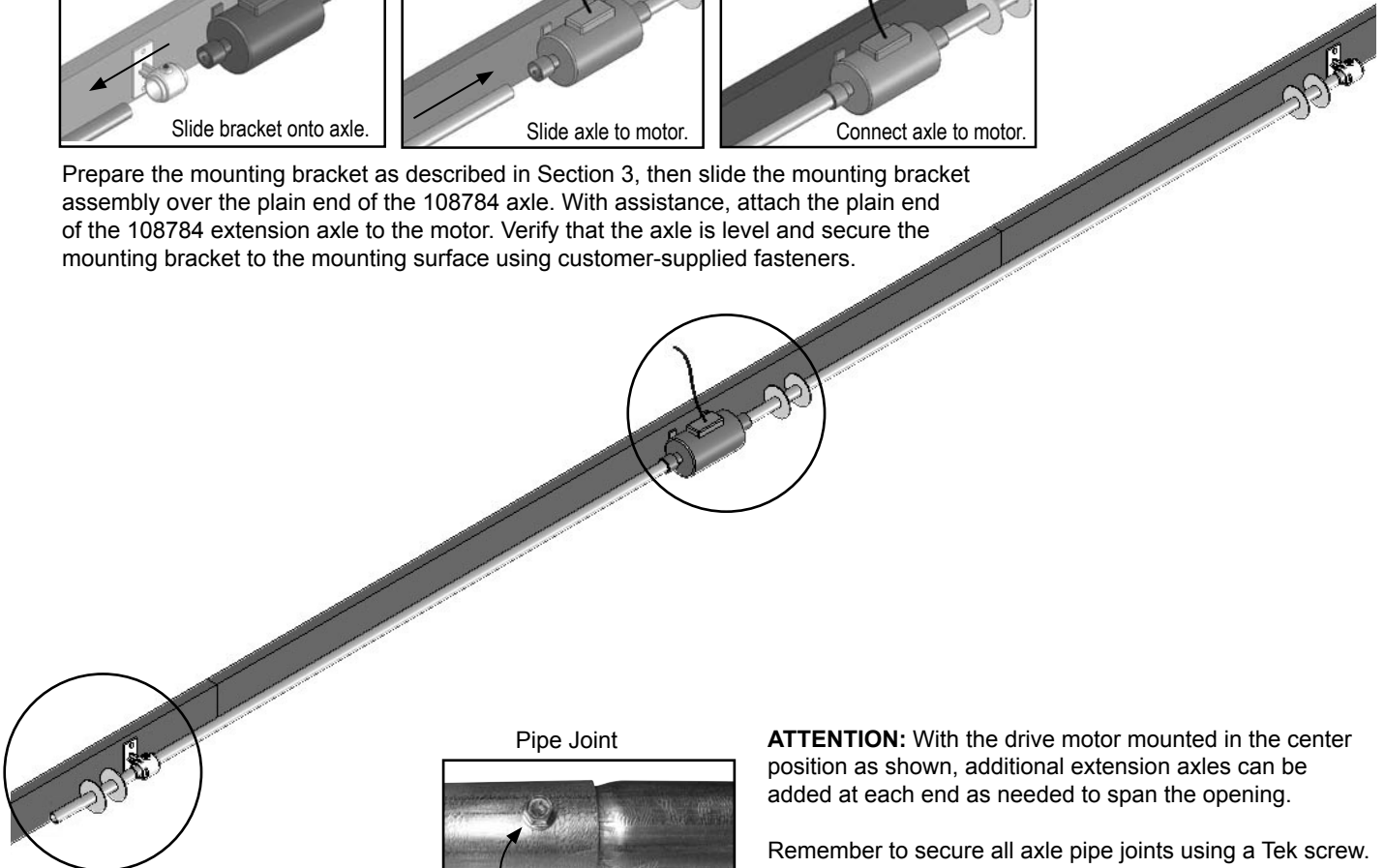

ATTENTION: With the drive motor mounted in the center position as shown, additional extension axles can be added at each end as needed to span the opening.

Remember to secure all axle pipe joints using a Tek screw. Position mounting bracket so that it will not interfere with the installed Tek screw at the axle joints.

5

INSIDE MOUNT OPTION

In some instances, it may be best to install the roll-up drive assembly within the framed opening as shown in the following diagrams. (Earlier examples show the motor and axles attached above the opening.)

Review the previous pages and the diagrams below for installation instructions.

Level all extension axles to ensure proper operation. After installing the motor and drive axles, connect the motor to the electrical system.

CONNECTING THE ELECTRIC MOTOR TO THE ELECTRICAL SYSTEM MUST BE COMPLETED BY A QUALIFIED ELECTRICIAN.



Drawing shows the electric roll-up room divider installed within a framed opening. Panel and straps are installed later.

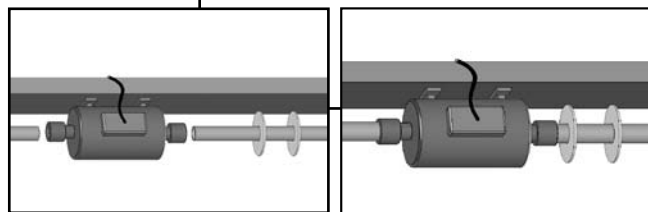
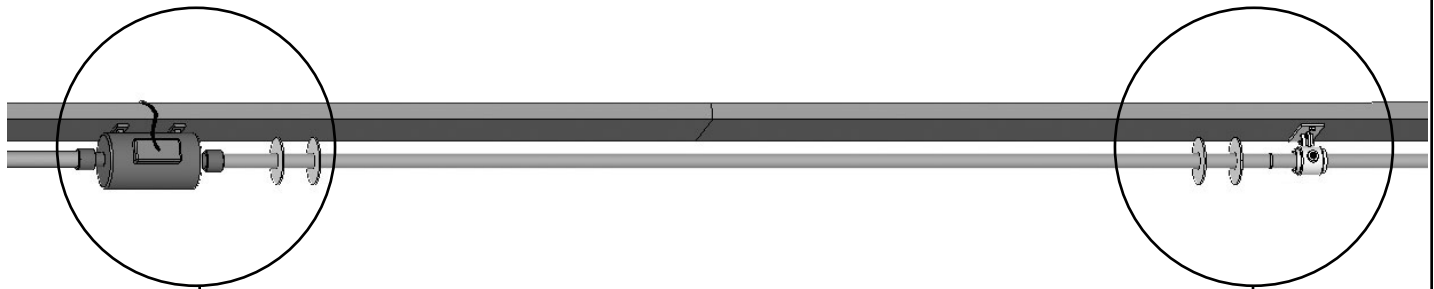
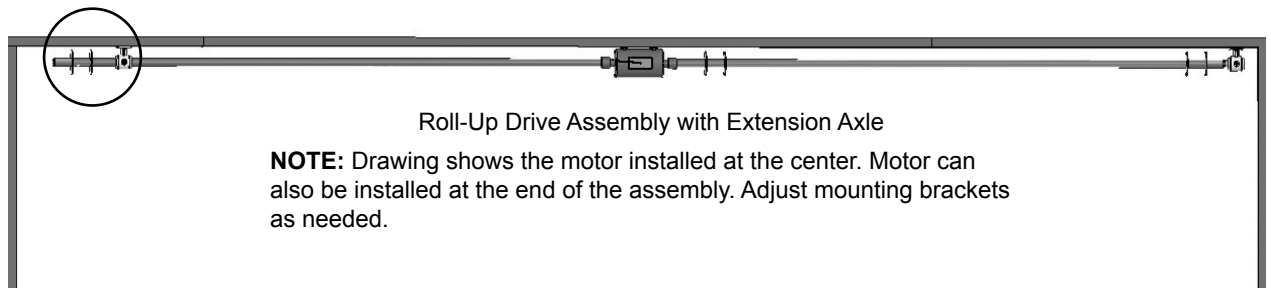
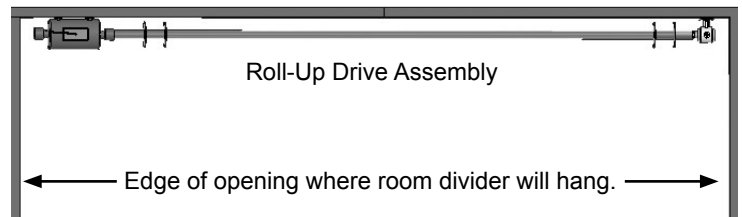

Attach axles to the motor.

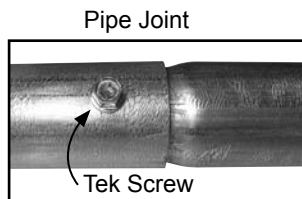

Position bracket so that it is 6" to 8" from the pipe joint. Secure each axle pipe joint using a Tek screw.

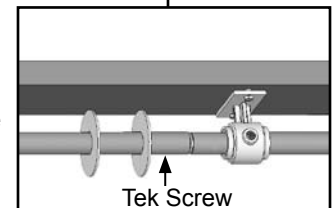

6

INSTALL PANEL STRAPS

Panel straps extend from the top of the framed opening (header), down to the floor, and back up to the mounting surface. These steps describe one way to install the panel straps:

First, evenly roll the excess room divider panel onto the conduit as shown below. The rolled panel will rest on the floor when rolled correctly.

Next, measure the amount of strap needed for each panel guide and cut strap to required length. Allow an extra 12" inches to connect the strap to the strap guide.

Example: $(\text{Height of Panel} \times 2) + 12" = \text{Strap Length}$
(For some applications, adjust length as needed to properly secure the strap to the framed opening. This may or may not exceed 12" for the additional length.)

With assistance and lifts or ladders, first attach each panel strap to the axle between the strap guides as shown below using two Tek screws for each strap.

Run each panel strap down to floor, under the conduit pipe and panel, and back up to the mounting surface. Pull snug to remove the slack, and attach each strap using customer-supplied fasteners.

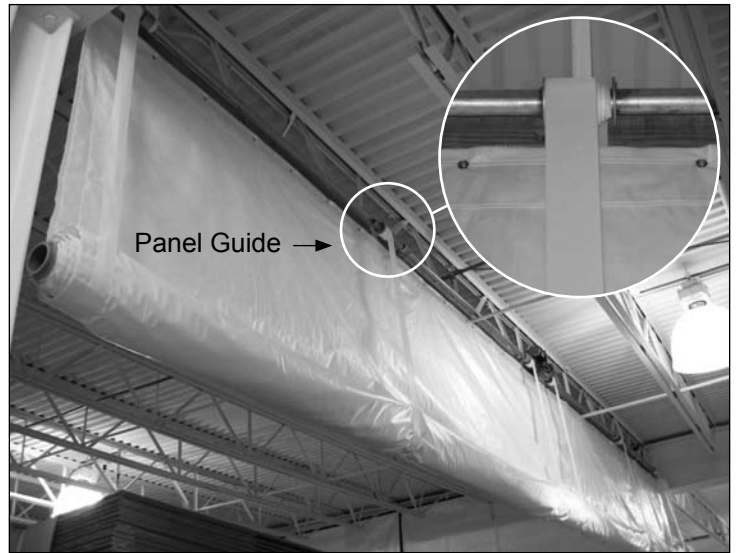

Keep straps in line with the strap guides of the drive axles.

With all straps installed and the motor wired to a power supply, test the operation of the roll-up room divider.

Verify that the panel rolls smoothly and evenly around the conduit pipe and the axles. Adjust straps as needed to achieve the best results and to keep them aligned when the curtain is operated.

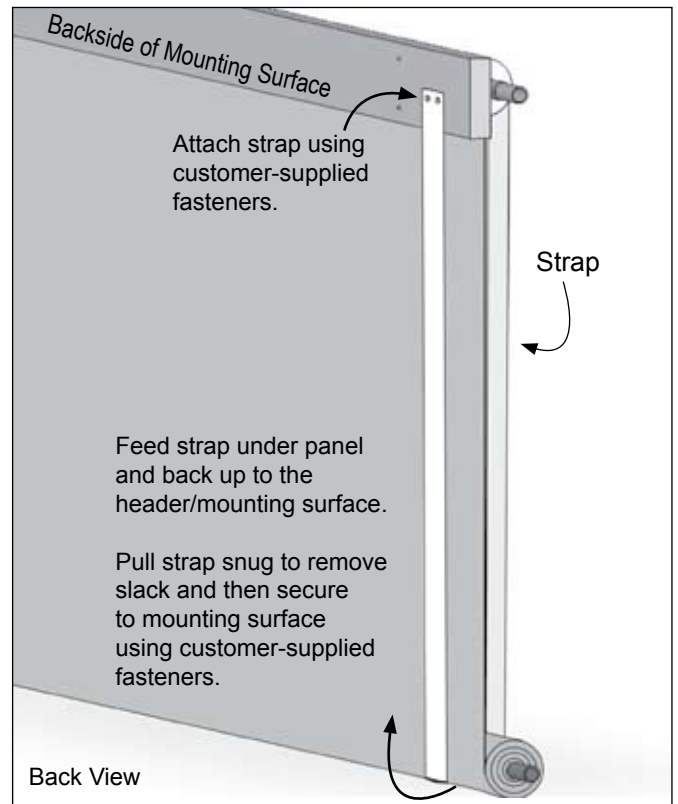
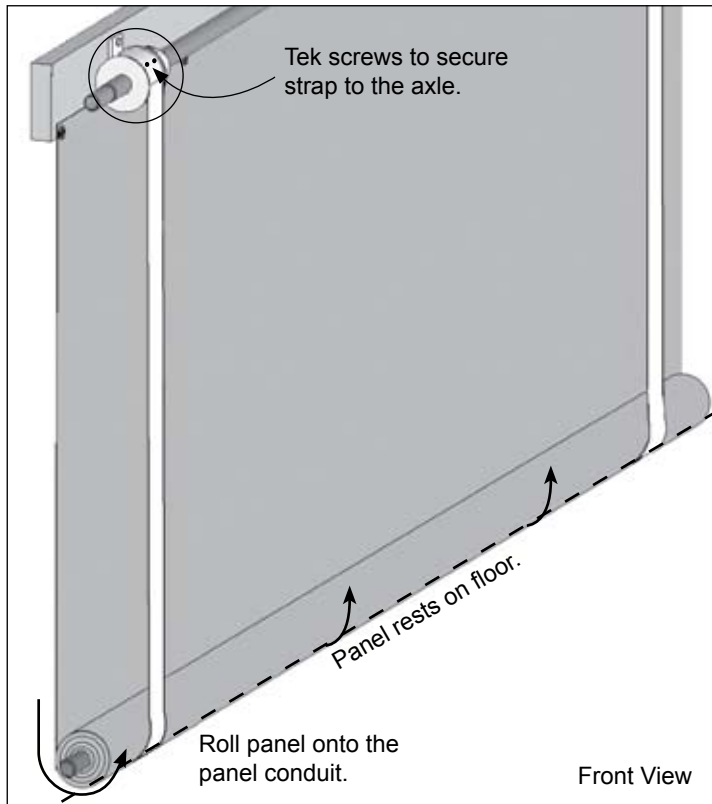



Page reserved for customer notes.