



ClearSpan™ Herculean Carport



Photo may show a different but similar model.

©2009 ClearSpan™
All Rights Reserved. Reproduction
is prohibited without permission.

STK#	DIMENSIONS
107834	12' W x 20' L
107835	12' W x 30' L
107836	12' W x 40' L
107837	12' W x 50' L



YOU MUST READ THIS DOCUMENT BEFORE YOU BEGIN TO ASSEMBLE THE SHELTER.

Thank you for purchasing this ClearSpan™ shelter. When properly assembled and maintained, this product will provide years of reliable service. These instructions include helpful hints and important information needed to safely assemble and properly maintain the shelter. Please read these instructions **before** you begin.

If you have any questions during the assembly, contact Customer Service for assistance.

SAFETY PRECAUTIONS

- Wear eye protection.
- Wear head protection.
- Wear gloves when handling metal tubes.
- Use a portable GFCI (Ground Fault Circuit Interrupter) when working with power tools and cords.
- Do not climb on the shelter or framing during or after construction.
- Do not occupy the shelter during high winds, tornadoes, or hurricanes.
- Provide adequate ventilation if the structure is enclosed.
- Do not store hazardous materials in the shelter.
- Provide proper ingress and egress to prevent entrapment.

ANCHORING INSTRUCTIONS

Prior to assembling this shelter, please read the **MUST READ** document included with the shipment.

⚠ WARNING: The anchor assembly is an integral part of the shelter construction. Improper anchoring may cause shelter instability and failure of the structure. Failing to anchor the shelter properly *will void the manufacturer's warranty* and may cause serious injury and damage.

LOCATION

Choosing the proper location is an important step before you begin to assemble the structure.

The following suggestions and precautions will help you determine whether your selected location is the best location.

- Never erect the structure under power lines.
- Identify whether underground cables and pipes are present *before* preparing the site or anchoring the structure.
- Location should be away from structures that could cause snow to drift on or around the building.
- Do not position the shelter where large loads such as snow and ice, large tree branches, or other overhead obstacles could fall.

SITE

After choosing a location, proper preparation of the site is essential. Follow the information below.

- *A level site is required.* The site must be level to properly and safely erect and anchor the structure.
- For sites that are not concrete or gravel, placing wood blocks or other suitable supports under each rafter leg helps prevent the pipes from sinking or working into the site.
- Drainage: Water draining off the structure and from areas surrounding the site should drain away from the site to prevent damage to the site, the structure, and contents of the structure.

⚠ WARNING: The individuals assembling this structure are responsible for designing and furnishing all temporary bracing, shoring and support needed during the assembly process. For safety reasons, those who are not familiar with recognized construction methods and techniques must seek the help of a qualified contractor.

ASSEMBLY PROCEDURE

Following the instructions as presented will help ensure the proper assembly of your shelter. Failing to follow these steps may result in an improperly assembled and anchored shelter and will void all warranty and protection the owner is entitled.

The steps outlining the assembly process are as follows:

1. Verify that all parts are included in the shipment. Notify Customer Service for questions or concerns.
2. Read these instructions, the Must Read document, and all additional documentation included with the shipment **before** you begin assembling the shelter.
3. Gather the tools, bracing, ladders (and lifts), and assistance needed to assemble the shelter.
4. Check the weather **before** you install the roof cover and any panels (if equipped). Do not install covers or panels on a windy or stormy day.
5. Re-evaluate the location and site based on the information and precautions presented in the documentation included with the shipment.
6. Prepare the site (if applicable).
7. Assemble the frame components in the order they are presented in these instructions.
8. Assemble the frame including the struts (if equipped).
9. Consult the MUST READ document and properly anchor the assembled frame.
10. Install, tighten, and secure the main cover and panels (if equipped). This applies to fabric covers that stretch over the frame assembly. Your shelter may include roof panels or side panels or both.
11. Read the Care and Maintenance information at the end of these instructions.
12. Complete and return all warranty information as instructed.

LIST OF WORDS AND PHRASES

Before you begin, it is important to become familiar with the words and phrases used in this instruction manual.

These words and phrases are common to most ClearSpan™ shelters and identify the different parts of the shelter. (Some are used in this document. Others may not apply to this particular shelter.) These terms describe the shipped parts and can also be found on the materials list/spec sheets included with the shipment. To aid in the assembly, read through the following definitions before you begin to assemble your shelter.

- **Conduit:** An assembly of pipes used to secure the main cover and end panels (if equipped). Purlins and some strut assemblies also consist of connected pipes to form a conduit. Each pipe joint of a conduit assembly is secured with a self-tapping Tek screw.
- **Coupler or Fitting:** A part of the frame assembly where legs, purlins and rafter pipes are inserted and secured. In most instances, 3-way and 4-way couplers are used. In some larger applications, couplers are used to secure the joints of the different rafter sections during the assembly of the rafters. Some shelters do not use couplers.
- **Foot or Rafter Foot:** The part attached to and found at the base of the rafter or leg of the shelter. Depending on the shelter, the foot is an optional purchase. Some shelters do not offer an optional foot. Some use 1-way connectors; some use ground posts.
- **Must Read Document:** This document includes building and shelter anchoring instructions, steps for end wall reinforcement, safety precautions, and notices and warnings. The Must Read document is sent with all shelters and buildings. If you did not receive a Must Read document, contact Customer Service to request one.
- **On-Center:** Term used to describe a measurement taken from the vertical center of the rafter or frame member to the vertical center of another.
- **Purlin:** The pipe assembly that runs perpendicular to the rafters or framework that supports the main cover. Purlins are found on the sides and roof areas of the assembled frame, are evenly spaced, and typically run from the front to the back of the shelter.
- **Plain or Straight Pipe:** A term used to describe a pipe that has the same diameter or width throughout its entire length.
- **Strut:** A strut is usually a length of pipe with two flattened ends and is used for diagonal bracing of the shelter frame. A strut is typically secured to the frame work by special brackets and bolts.
- **Swaged End or Swaged Pipe:** The term “swaged” refers to the tapered end of the pipe or tube. Swaged ends of a pipe can be inserted into couplers and the straight ends of other pipes.
- **Tek screw:** A self-tapping fastener used to secure pipe joints and to fasten brackets to rafters.

CLEARSPAN™ CARPORTS

REQUIRED TOOLS

The following list identifies the main tools needed to assemble the shelter. Additional tools and supports may be needed depending on the structure, location, and application.

- Tape measure or measuring device
- Variable speed drill and impact driver (cordless with extra batteries works best)
- Wrenches or ratchet and socket set (recommended)
- 5/16" Hex key wrench
- Two ropes long enough to reach over the shelter (The use of rope depends on the height of the shelter. Other main cover installation methods may not use rope.)
- Hammers, gloves and eye protection
- Duct tape (supplied by customer)
- Box cutter or utility knife
- Ladders, work platforms, and other machinery for lifting designed to work safely at the height of the shelter

UNPACK AND IDENTIFY PARTS

The following steps will ensure that you have all the necessary parts before you begin to assemble the shelter.

1. Unpack the contents of the shipment and place where you can easily inventory the parts. Refer to the Bill of Materials/Spec Sheets.
2. Verify that all parts listed on the Bill of Materials/Spec Sheets are present. If anything is missing or you have questions, consult the Pictorial Parts Guide and all shelter diagrams for clarification, or contact Customer Service.

NOTE: At this time, you do not need to open the plastic bags containing smaller parts such as fasteners or washers.

QUICK START GUIDE

For an overview of this shelter and to see the main connection details, consult the diagrams in the Quick Start Guide located at the back of these instructions.

Optional Ground Post Installation (additional purchase)

In addition to the frame installation steps, these instructions describe installing an optional ground posts. (Additional purchase required.)

The ground post kit, which includes the components needed to attach the ground posts to the frame, is an additional purchase. Contact your sale representative to purchase a ground post anchoring kit if desired.

If an optional ground post anchoring kit has been purchased, the ground posts must be driven to the proper depth. Width of the shelter is measured from the center of one ground post to the center of the remaining ground post.

The rafter legs and fittings are then attached onto the ground posts and tighten. *Tee couplers and cross connectors must remain at ground level.*

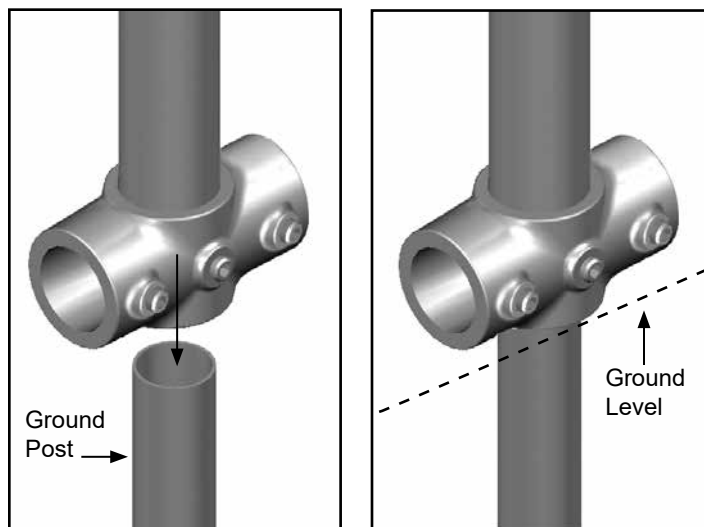

If the optional ground post kit was purchased, consult the ground post installation information presented within this guide for additional details before setting the posts.

NOTE: To secure the rafter to the ground post, drill one mounting bolt hole through each rafter leg pipe and ground post once the frame is assembled.

Insert the mounting bolt, included with the ground post kit, through the hole and secure with the nut. Tighten the bolt and nut.

ClearSpan

The following graphics and photos will help you identify the different parts. (Some parts are not shown.)



FA4482B
Tek screw



100441
Nut Setter



QH1061
Ratchet



CC6214
Fabric Clip

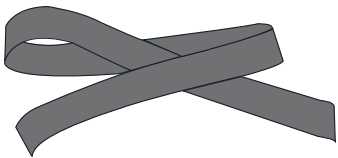

103620b
Plain End Strap

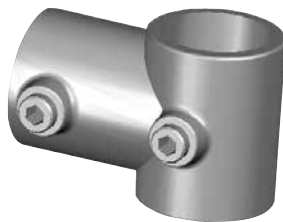

10015108
Tee Coupler

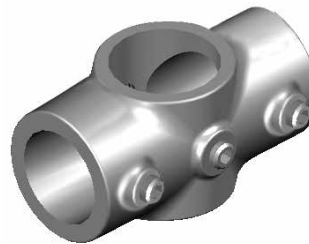

10015808
Cross Connector



107623
3-Way Coupler



107622
4-Way Coupler

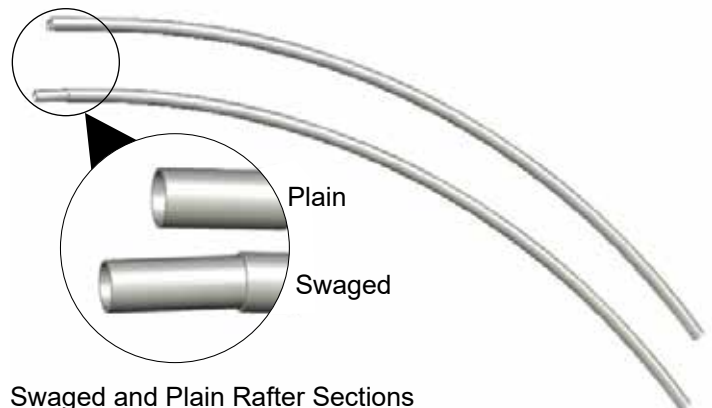

Swaged and Plain Rafter Sections

CLEARSPAN™ CARPORTS

ADDITIONAL PARTS IDENTIFICATION NOTES

In some instances, there can be differences between the parts that are shown and referenced in the instructions and the parts that are shipped with the shelter. These differences *do not* affect the integrity of the shelter, but can change the assembly procedures.

The information that follows identifies possible changes in the assembly procedure found in this instruction document. *Please implement these changes during the assembly of the shelter.*



3-Way Coupler (no lock bolt)



3-Way Coupler (includes lock bolt)



4-Way Coupler (no lock bolt)



4-Way Coupler (includes lock bolt)

There can be two types of couplers used during the assembly of the shelter: those that include an installed locking eyebolt and those that do not. See above.

If the couplers included with your shelter do not have an installed lock bolt, use a *self-tapping Tek screw* to secure the different pipes to the couplers during the assembly process. The self-tapping Tek screws are included with the shipment.

ATTENTION: Tek screws are sent with all shelters of this type. For couplers with locking eyebolts, install the Tek screws at each pipe connection for additional security if desired.

⚠ WARNING: To prevent personal injury and damage to the shelter, *fasten and tighten a Tek screw* at each pipe and coupler joint.

To prevent cover damage, install the Tek screw so that it *does not* touch the main cover or any optional side or end panels once these are installed.

ClearSpan™ Herculean Carport

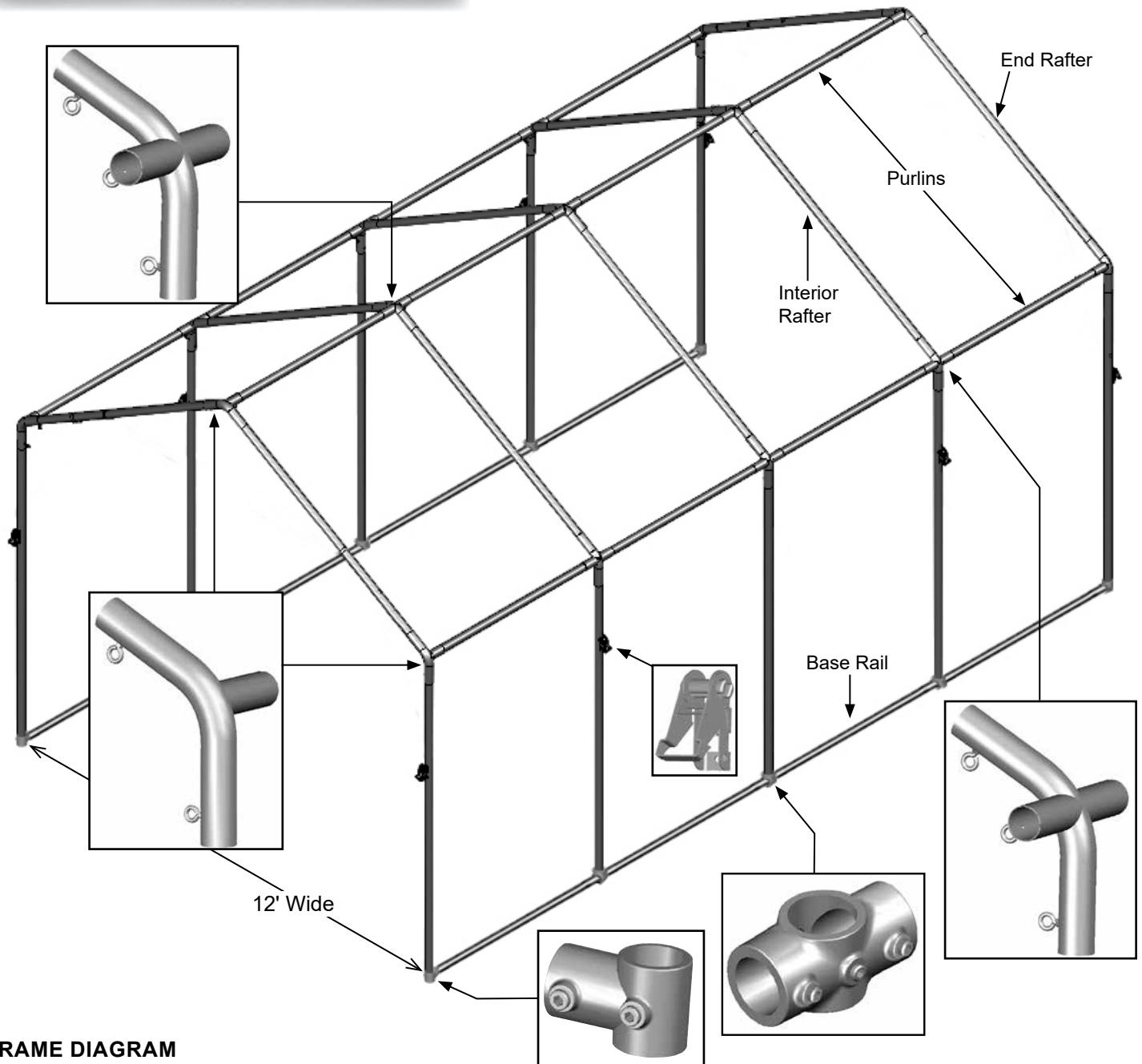

FRAME DIAGRAM

NOTE: Diagram above may show a shelter that differs in length from the actual frame. The use and positions of ratchets may also differ from actual shelter. Frame above is used for illustration purposes.

CLEARSPAN™ CARPORTS

LAY OUT THE BUILDING SITE

After the site is prepared, identify the location of the shelter corners to help square the frame after it is assembled.

Taking these steps **before** assembling the shelter saves time and ensures that the structure is positioned as desired. The following procedure is a suggested method. Its use depends on the size of the shelter, shelter application, the footings, and the method used to anchor the shelter.

SQUARE THE SITE

1. Identify a corner where a building rafter will be positioned, drive in a stake, and string a line the exact width of the building and stake in place.
2. Sting a line at least as long as the building from the first stake at 90°.

NOTE: A transit can be used to ensure an accurate 90° angle, or the 3-4-5 rule can be used. Refer to diagram. Using multiples of 3-4-5 such as 6-8-10 or 12-16-20 helps to maintain an accurate 90° angle.

3. After squaring the position of the building and placing a stake at all corners, string a line between the stakes to mark the base of the building.

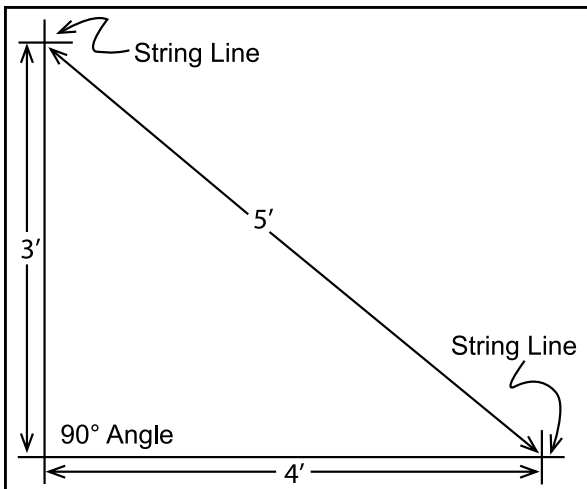

If an optional ground post anchoring kit has been purchased, the ground posts must be driven to the proper depth. Width of the shelter is measured from the center of one ground post to the center of the remaining ground post.

ATTENTION: Skip this procedure and continue with the rafter assembly steps if ground posts are not used.

Gather the parts:

- Ground posts
- Post driver

1. Identify a corner where a ground post will be positioned and drive the first corner ground post into the ground.

NOTE: Flip the ground post so the non-drilled end (no bolt holes) is up and insert the ground post driver into the post. Drive the post into the ground. When properly driven, *the non-drilled end of the ground post will be one (1) foot above the finished grade.*

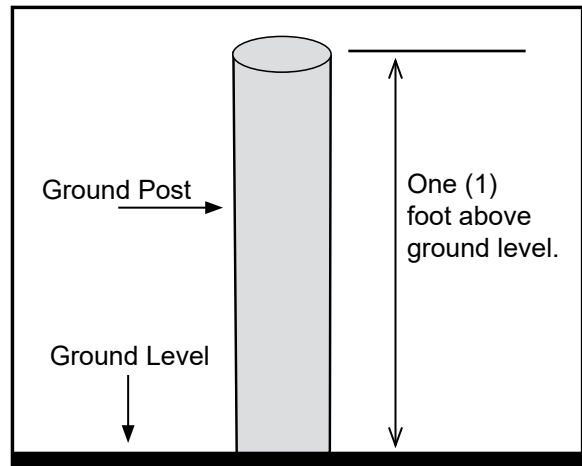

2. After the first corner ground post is in place, string a line the width of the building (12' center-to-center) and drive the second corner ground post into the ground just enough to hold it in place.
3. Use a transit or line level to drive the second corner ground post to the same depth as the first ground post.
4. String a line at least as long as the building 90° from the line between the first and second corner ground posts.
5. After squaring the position of the building, measure the length and drive the third corner ground post.
6. Repeat the same step for the last corner ground post.

NOTE: The distance measured diagonally between corner ground posts must be equal for the building to be square.

7. Check all dimensions (and adjust if needed) before driving the remaining posts to the required height.
8. After all four corner posts are accurately installed, tie a string line between the tops of the corner ground posts on the same side of the shelter. The string is used to identify the tops of all remaining ground posts. The string must remain tight and level.
9. Use a tape measure to mark the 5' on-center locations of the remaining ground posts.
10. Drive the remaining ground posts into the ground at the required 5' on-center width and to the height identified by the string.

NOTE: Verify that each ground post is plumb and driven to the correct depth.

11. Continue with the **End Rafter Assembly** instructions.

END RAFTER ASSEMBLY (2)

Gather the parts:

- Pipes 1.90" x 96" plain (190P096)
- Pipes 1.90" x 78.5" plain (190P0785)
- 3-way couplers (#107623)
- 4-way couplers (#107622)
- 10015108 fittings
- Fabric clips (#CC6214) & 5/16" Hex key wrench

NOTE: Assistance is required to assemble the shelter.

1. Select the four (4) pipes needed to assemble each end rafter and arrange on the ground adjacent to the correct couplers shown below.
2. Connect 3-way couplers (#107623) to the pipes shown below to form the end rafters.

NOTE: Attach one fabric clip (CC6214) to one end of each 1.90" pipe and insert the end with the clip into the 3-way couplers (end rafters) or 4-way couplers (interior rafters).

To prepare each frame pipe, slide a pipe into the required coupler, *draw a line on the pipe* to mark the coupler position, and remove the pipe. Take one CC6214 clip and snap it onto the pipe end just above the mark. Insert the pipe end with the clip into the coupler, align the clip with the locking screw, and tighten the locking screw against the clip.

3. Slide one tee coupler (#10015108) onto each end rafter leg. Tighten the Allen screws to secure the coupler to the leg pipes. *Position the Allen screws to the inside of the frame.*
4. After the end rafters are assembled, continue with the **Frame Assembly** instructions that follow.

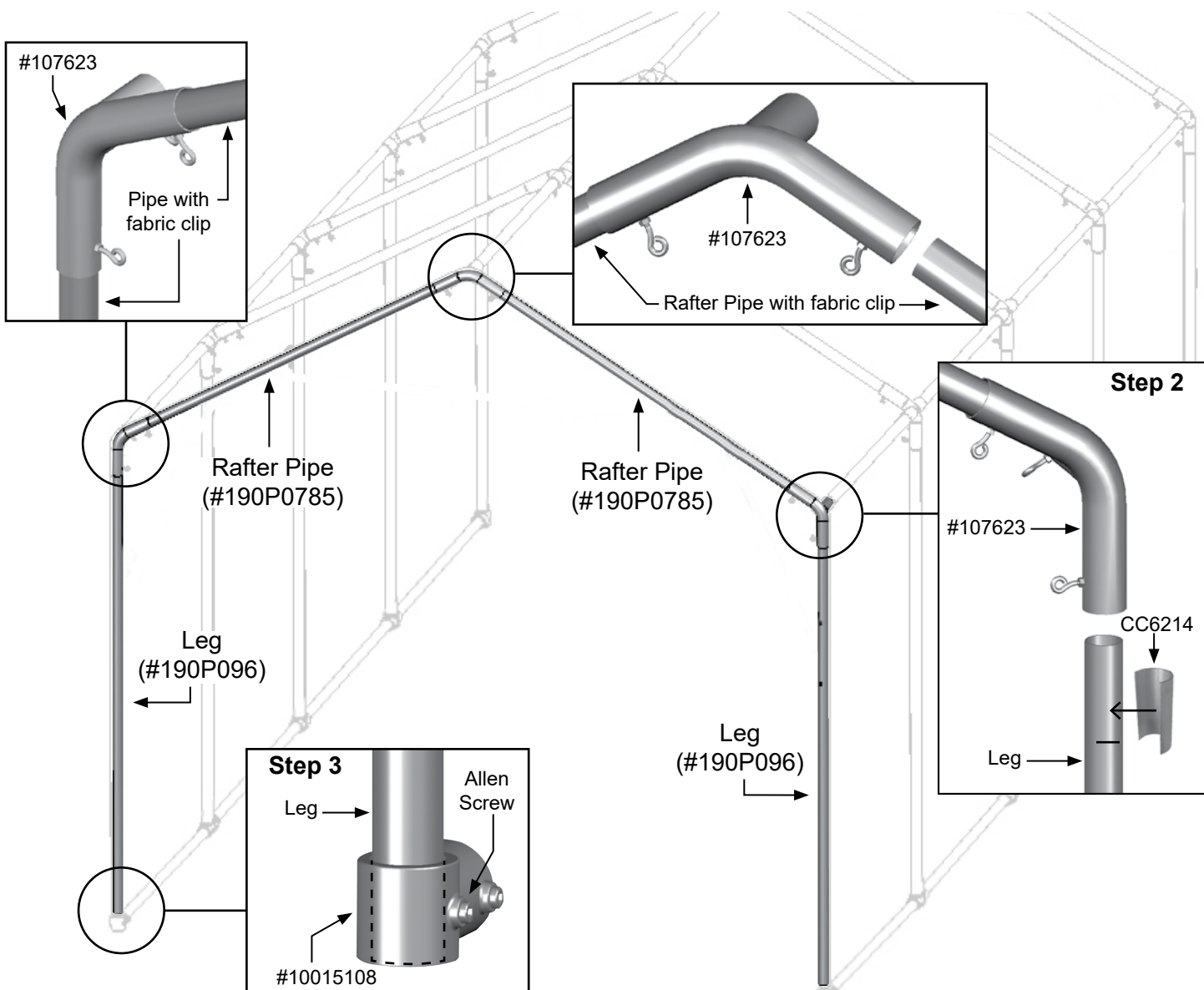

CLEARSPAN™ CARPORTS

FRAME ASSEMBLY

This section describes assembling the shelter frame.

1. Stand one end rafter in place. (Additional assistants are required to hold the rafter in position.) Check that the rafter is standing straight (plumb). *Position the open end of the couplers to the inside of the frame.*

NOTE: If using optional ground posts, place the rafter leg with fitting onto the ground posts and tighten couplers. *Tee couplers and cross connectors must remain at ground level.*

2. Take one 58" purlin pipe (#190P058), insert it into the end rafter coupler, and mark the clip location on the pipe. Remove the pipe, snap the clip into place, and insert the pipe into the 3-way coupler (#107623). Tighten the screw. Repeat for the remaining pipes.

3. Connect the rafter pipes (#190P0785) and legs (#190P096) to the frame using the 4-way couplers (#107622) for the interior sections.

NOTE: Snap one fabric clip (CC6214) onto one end of each 1.90" pipe before inserting the pipe into the 3-way (end rafters) or 4-way (interior rafters) coupler.

4. Slide cross connectors (#10015808) onto each leg of the interior rafter.
5. Slide base rails (#190P058) into the interior rafter cross connectors and the end rafter tee couplers. Tighten the Allen screws to secure the base rails to the frame.
6. Continue adding pipe and fittings until the shelter length is reached. Attach the final end rafter to complete the frame assembly.

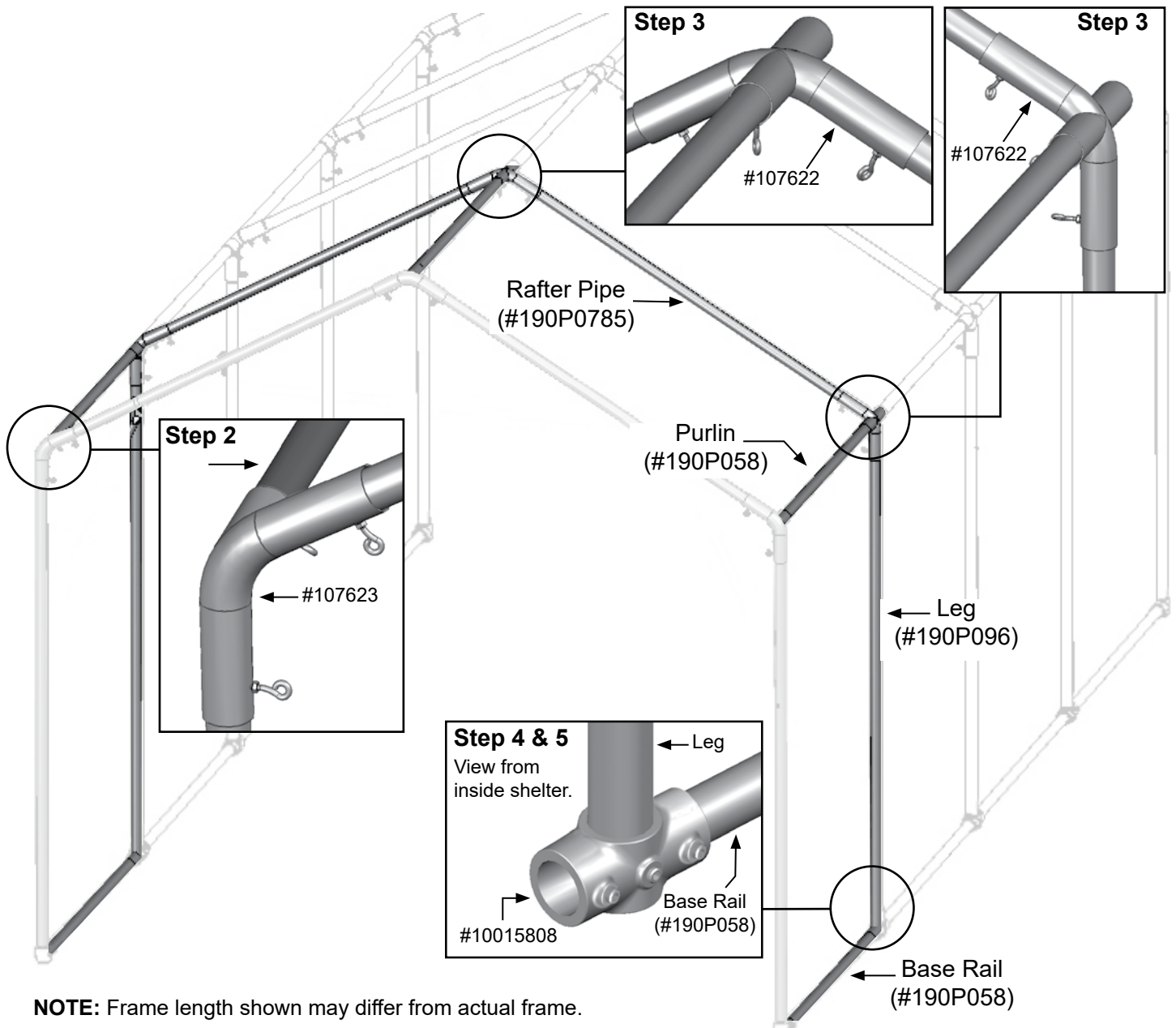

NOTE: Frame length shown may differ from actual frame.

SQUARE THE ASSEMBLED FRAME

Skip this section and continue with the ANCHOR THE SHELTER information if using the optional ground posts.

Gather the parts

- Measuring tape and assistants

Complete these steps:

1. With the frame in position, perform a final square of the frame by measuring diagonally (corner-to-corner) as shown below at the bottom of the legs. Verify that the two measurements are equal and adjust if needed.

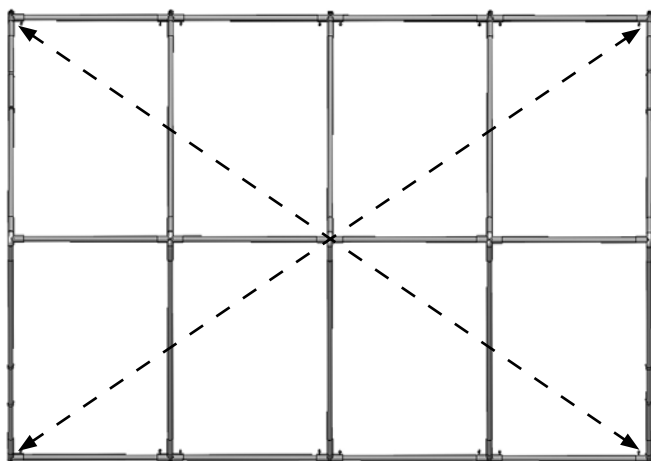

FRAME TOP VIEW

2. Measure width from center of rafter leg to center of other rafter leg of the same rafter assembly and adjust if needed. Repeat for all rafter assemblies.

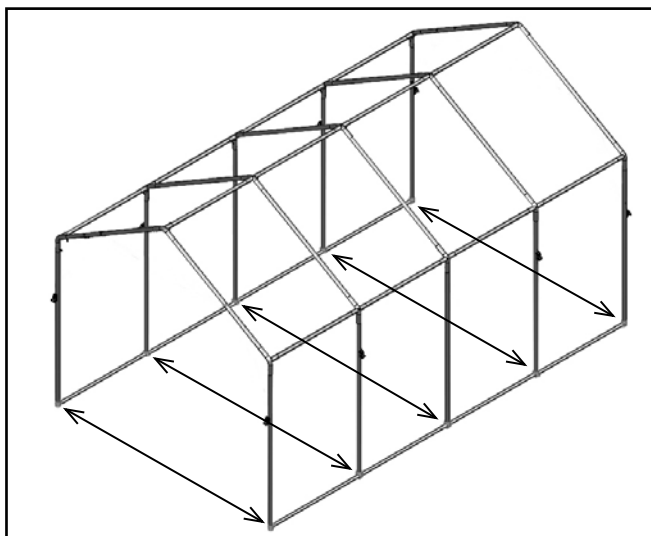

3. Examine the frame and remove any sharp edges from the frame or reposition screws (if equipped) so they do not come in contact with the roof cover.
4. After the frame is squared, read or reread the MUST READ document and anchor the shelter.

ANCHOR THE SHELTER

At this point, anchor the shelter. Consult the MUST READ document for anchoring information and suggestions. Please call customer service at 1-800-245-9881 for additional anchoring information.

CAUTION: The anchor assembly is an integral part of the shelter construction. Improper anchoring may cause shelter instability and failure of the structure to perform as designed. Failing to anchor the shelter properly will void the manufacturer's warranty and may cause serious injury and damage.

OPTIONAL INSTALLATION - END and/or SIDE PANELS

If the shelter includes the optional side panels and/or end panels, these panels **MUST** be attached to the frame *before* the cover is installed. If the shelter does not include the optional panels, continue with the main cover installation.

NOTE: Optional gable ends and side panels (additional purchase required) are attached to the frame using ball tie downs in the manner illustrated below. If equipped, secure the panels to the frame before installing the main cover.

1. Unpack panels and unfold completely.
2. After anchoring the frame, place the ball tie downs through the grommet holes and loop around the lower end rafter legs.

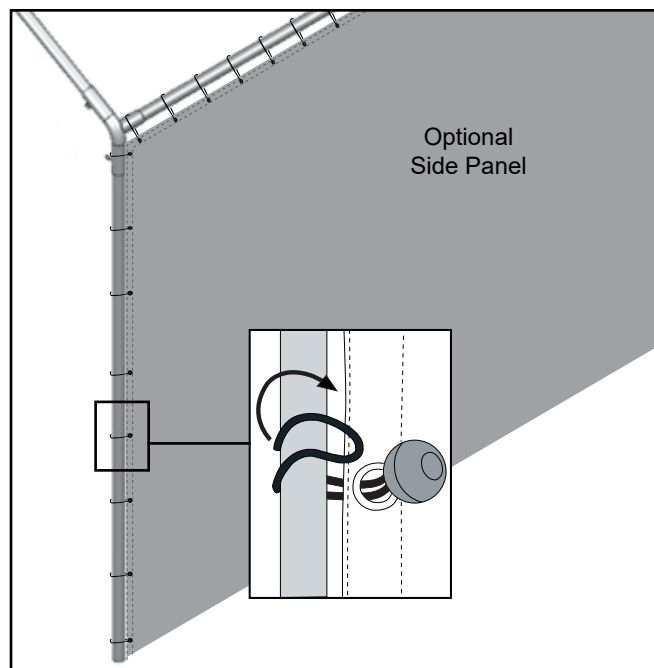

3. Install all side panels and/or end panels and continue with the main cover.

WARNING: Do not install panels without first anchoring the assembled frame.

CLEARSPAN™ CARPORTS

INSTALL MAIN COVER

Gather the parts:

- Ratchets (1" 4000lb)
- Pipe 1.315" (See chart below.)
- Cover
- Plain strap (#103620B)
- Ropes long enough to reach over the frame (supplied by customer)
- Tek screws and Fender washers
- Duct tape (supplied by customer)

⚠ WARNING: To prevent damage to the cover and to prevent serious personal injury, DO NOT attempt to install the cover on windy days.

1. Locate the pipes for two (2) main cover conduits. Each cover conduit consists of the following pipes. See chart below and the Side Profile Diagram for details.

Cover Conduit Lengths	
Length	Pipes
20'	(3) 75" & (1) 25.5"
30'	(4) 75" & (1) 73.5"
40'	(6) 75" & (1) 49.5"
50'	(8) 75" & (1) 25.5"

2. Connect these pipes by inserting the swaged ends of the pipes into the plain ends until each conduit is assembled. Secure each pipe joint with a Tek screw and wrap the joint with duct tape.

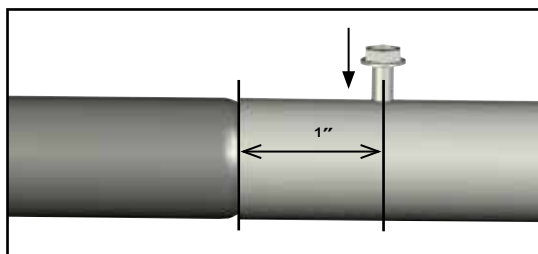

These cover conduits are inserted into the pockets sealed to the cover. The conduits are used to tighten and secure the cover.

3. After assembling the cover conduits, locate the cover and unfold it on a clean, smooth surface near the frame.

NOTE: When handling the cover and setting it in position, do not pull on the end straps. They will pull out of the cover. Unfold the cover with the inside surface facing up.

4. Locate the cover ends with strapping and align cover with the front and back of the shelter.
5. Insert the cover conduits into the pockets of the cover.

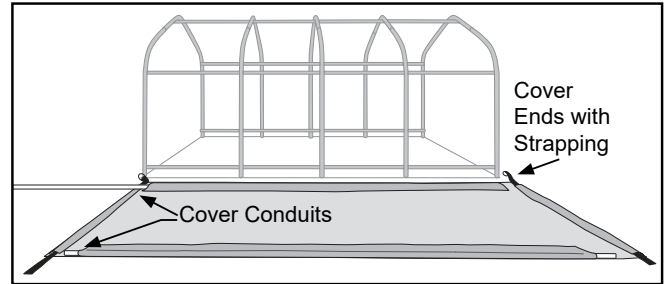

NOTE: Shelter shown above may differ in length and model from the actual shelter, used for illustration purposes only.

6. To pull the cover over the frame, attach ropes to both ends of the cover conduit. Wrap the rope around the conduit a few times to prevent it from slipping off.

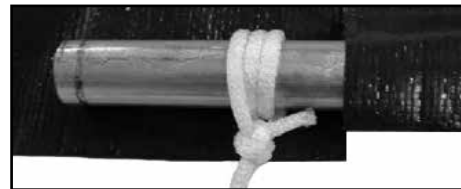

NOTE: Depending on the length of the cover it may be necessary to attach additional ropes to the cover conduit between the end ropes by cutting a small opening in the cover pocket and tying the rope around the conduit. DO NOT cut through the cover. *Cut through the conduit pocket only.*

7. With all ropes attached to the cover conduit, lift the conduit and carry the cover toward the base of the frame.
8. Toss the ropes over the frame and pull the cover into position. One person is required at each rope.
9. Center the cover end-to-end and side-to-side.

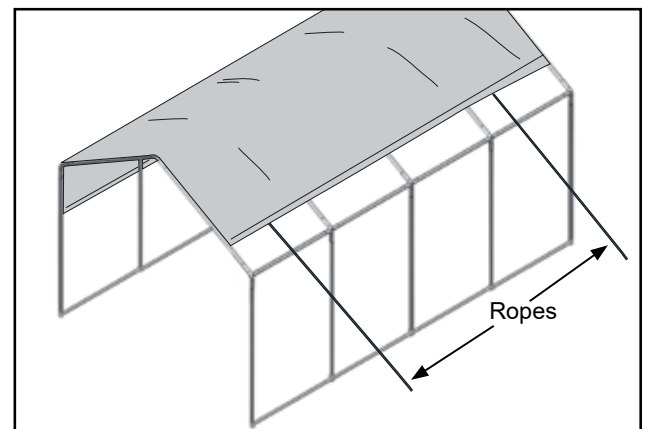

NOTE: Diagram shown without optional side or end panels.

INSTALL COVER (CONTINUED)

- At the ends, locate the black straps. Using the straps as guides, fasten ratchets to the outside of the end rafter legs using a Tek screw.

NOTE: Allow a few inches to remain between the end of the cover and the ratchet.

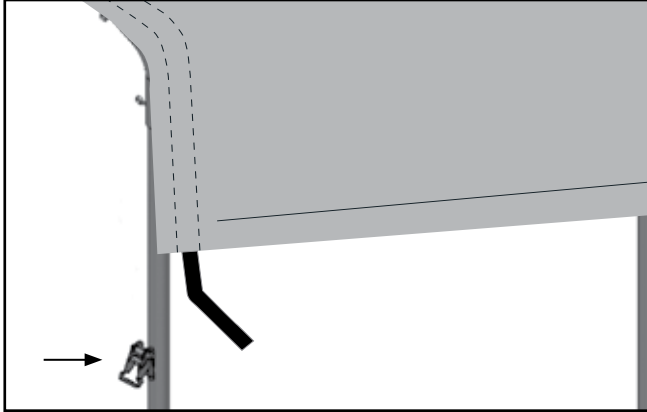

- At the ends, thread the straps into the ratchets and slightly tighten. *Do not tighten completely at this time.*

NOTE: It may be necessary to remove excess strap if it binds up in the ratchet.

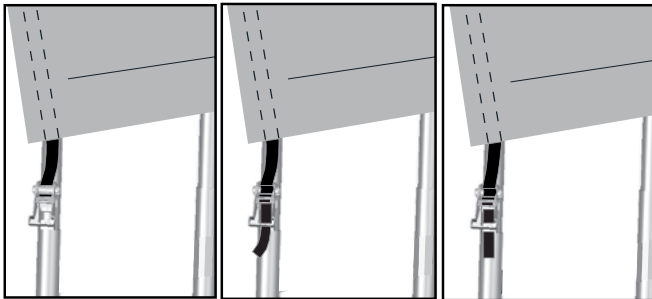

Drawings may show a different but similar model.

- Divide the remaining number of ratchets in half. Place the ratchets on the ground next to the rafter where they will be attached. *Consult the Side Profile diagram for ratchet locations and details.*

NOTE: Space ratchets evenly along each side of the shelter and directly across from each other on the *same rafter assembly*. Arrows identify approximate ratchet locations for the frame shown in this example.

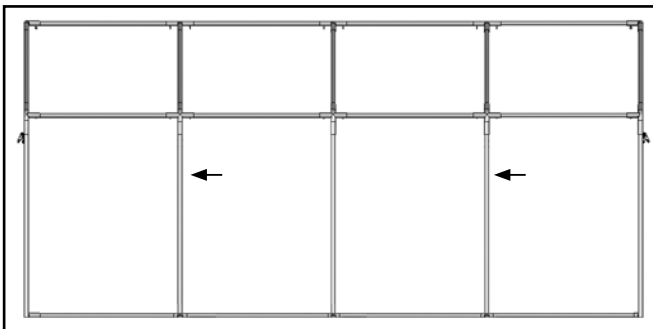

NOTE: Diagram above is an example of the 20' shelter.

- Using the main cover conduit and the straps as guides, attach the ratchets to the rafters at the proper height. Fasten ratchets to the outside of these rafters using a Tek screw for each ratchet.

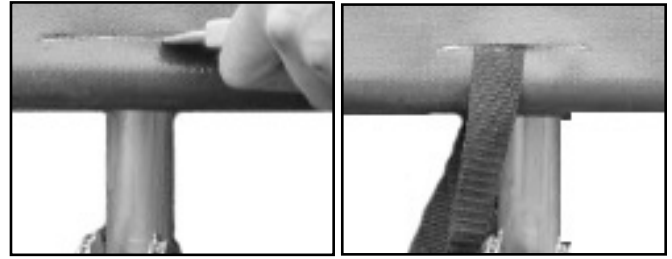

- Cut a slit in the cover conduit pocket at the rafter position. Insert a 3' section of strap through the slit and around the cover conduit.

NOTE: DO NOT cut through the main cover. *Cut through the conduit pocket only.*

- Thread the strap ends into a ratchet and slightly tighten.

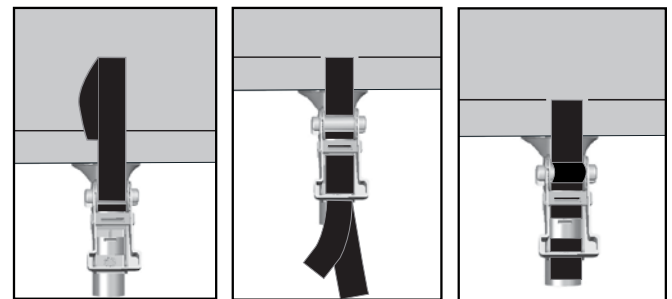

NOTE: It may be necessary to remove excess strap if it binds up in the ratchet.

- Repeat the steps for the remaining ratchets.
- Using additional help (if needed) tighten the main cover beginning with the ratchets along the side of the shelter frame.
- After the side ratchets are tightened, return to the end ratchets and tighten.

NOTE: Loosen the ratchets if needed to remove excess strap and retighten. Loosen all ratchet if needed to reposition the main cover on the frame and retighten the ratchets.

- Continue by reading the care and maintenance information that follows.

CLEARSPAN™ CARPORTS

SHELTER CARE AND MAINTENANCE

Proper care and maintenance of your shelter is important. Check the following items periodically to properly maintain your shelter:

- Regularly check the main cover and panels (if equipped) to see that these remain tight and in proper repair.
- Check connections and all fasteners to verify that they remain tight.
- Do not climb or stand on the shelter at anytime.
- Remove debris and objects that may accumulate on the shelter. Use tools that will not damage the cover when removing debris.
- Remove snow to prevent excess accumulation. Use tools that will not damage the cover when removing snow.
- Check the contents of the shelter to verify that nothing is touching the cover or the side panels that could cause damage.
- Check the anchoring system to ensure that all components are tight and in good repair.
- If the shelter is moved, inspect all parts and connections before reassembling.
- For replacement or missing parts, call 1-800-245-9881 for assistance.



Space below is reserved for customer notes.

NOTE: With the exception of Truss Arch buildings, ClearSpan™ shelters and greenhouses do not have any tested loading criteria.



QUICK START GUIDE

12' Wide Carports

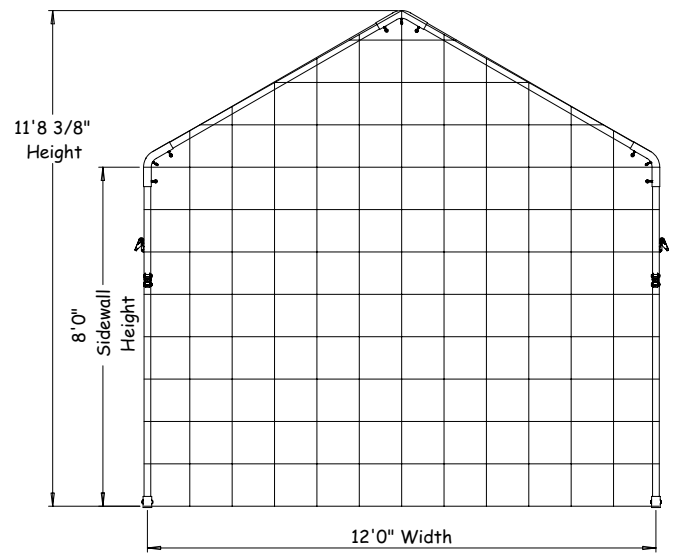

FRONT
Grid Represents 12" Squares

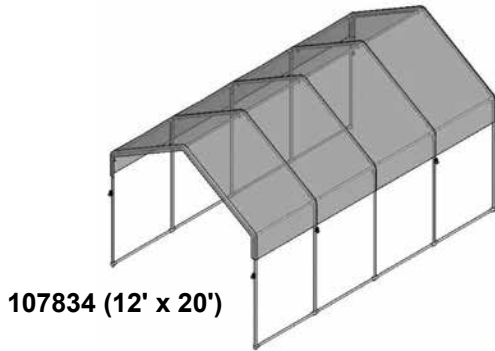

107834 (12' x 20')

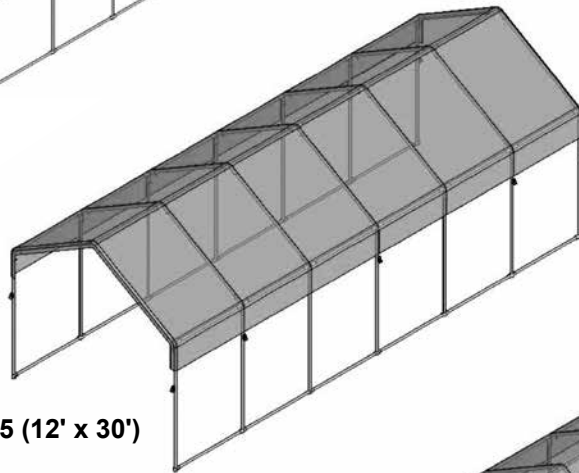

107835 (12' x 30')

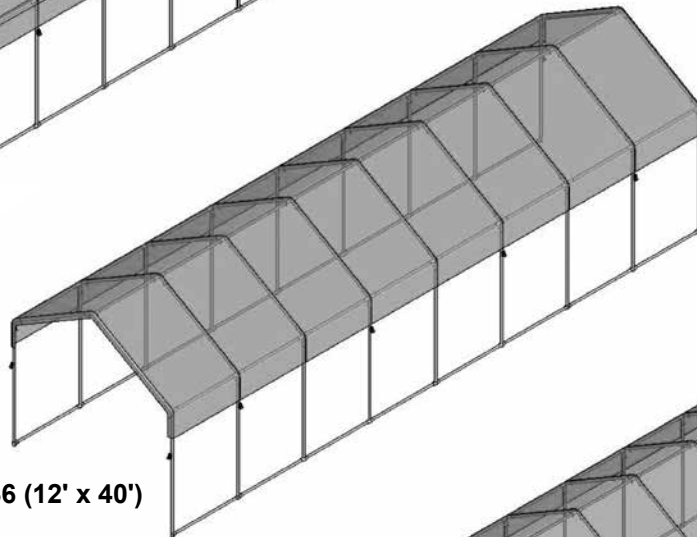

107836 (12' x 40')

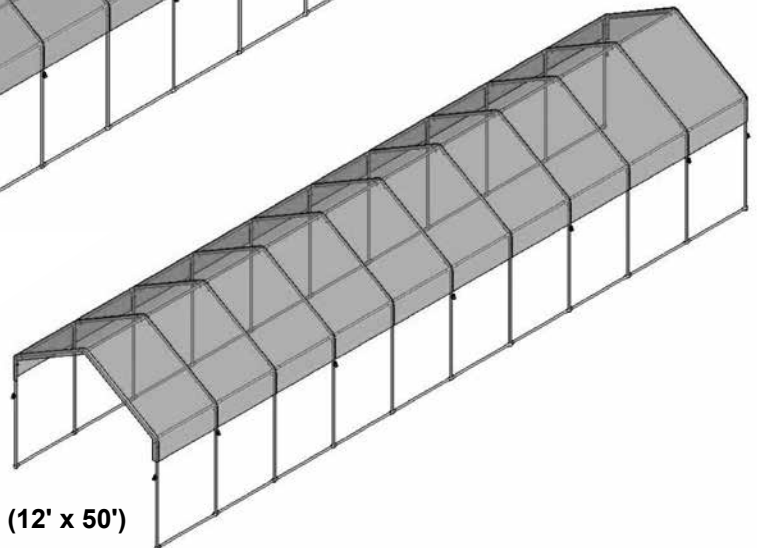

107837 (12' x 50')

FRONT PROFILE

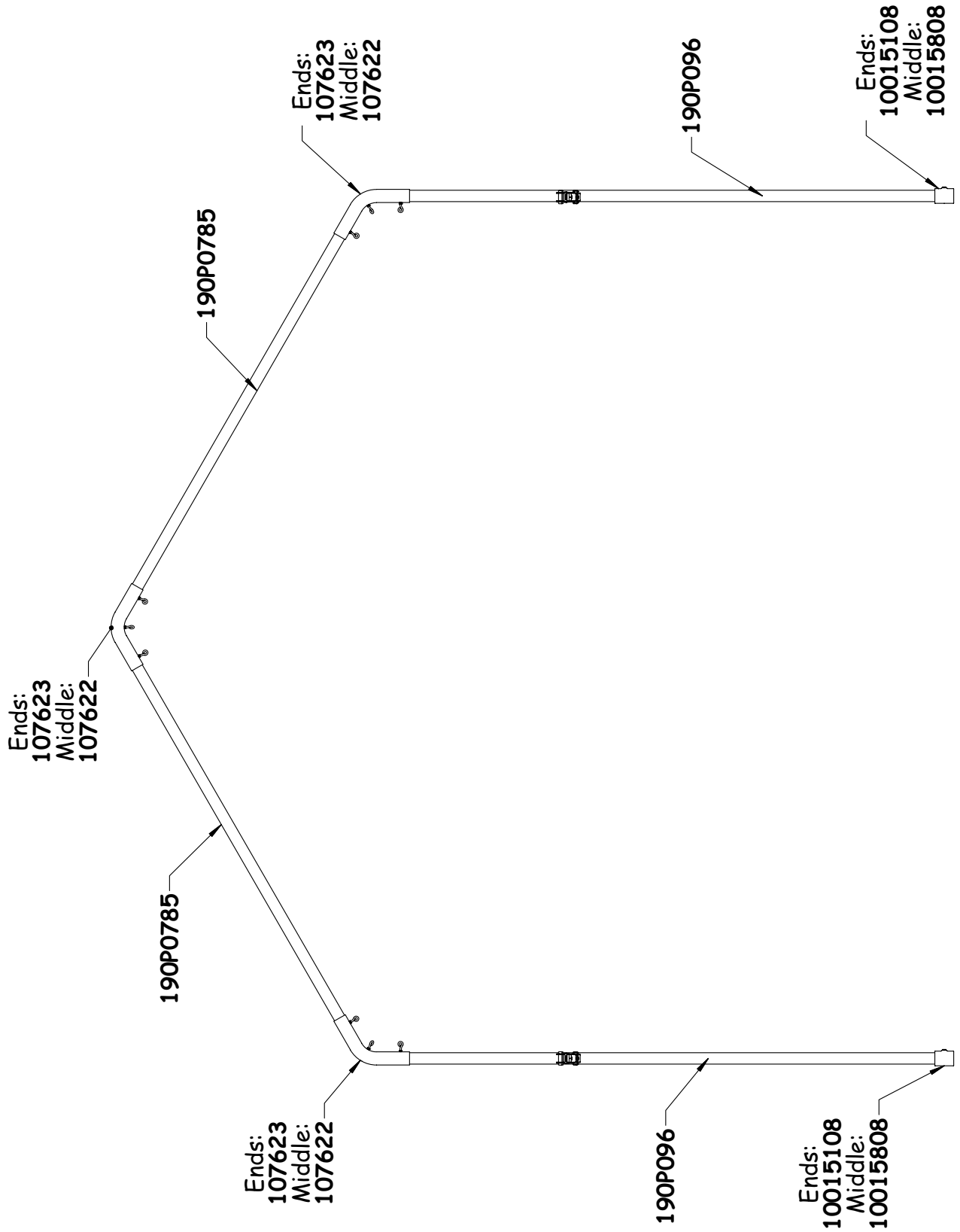

SIDE PROFILE - 107834

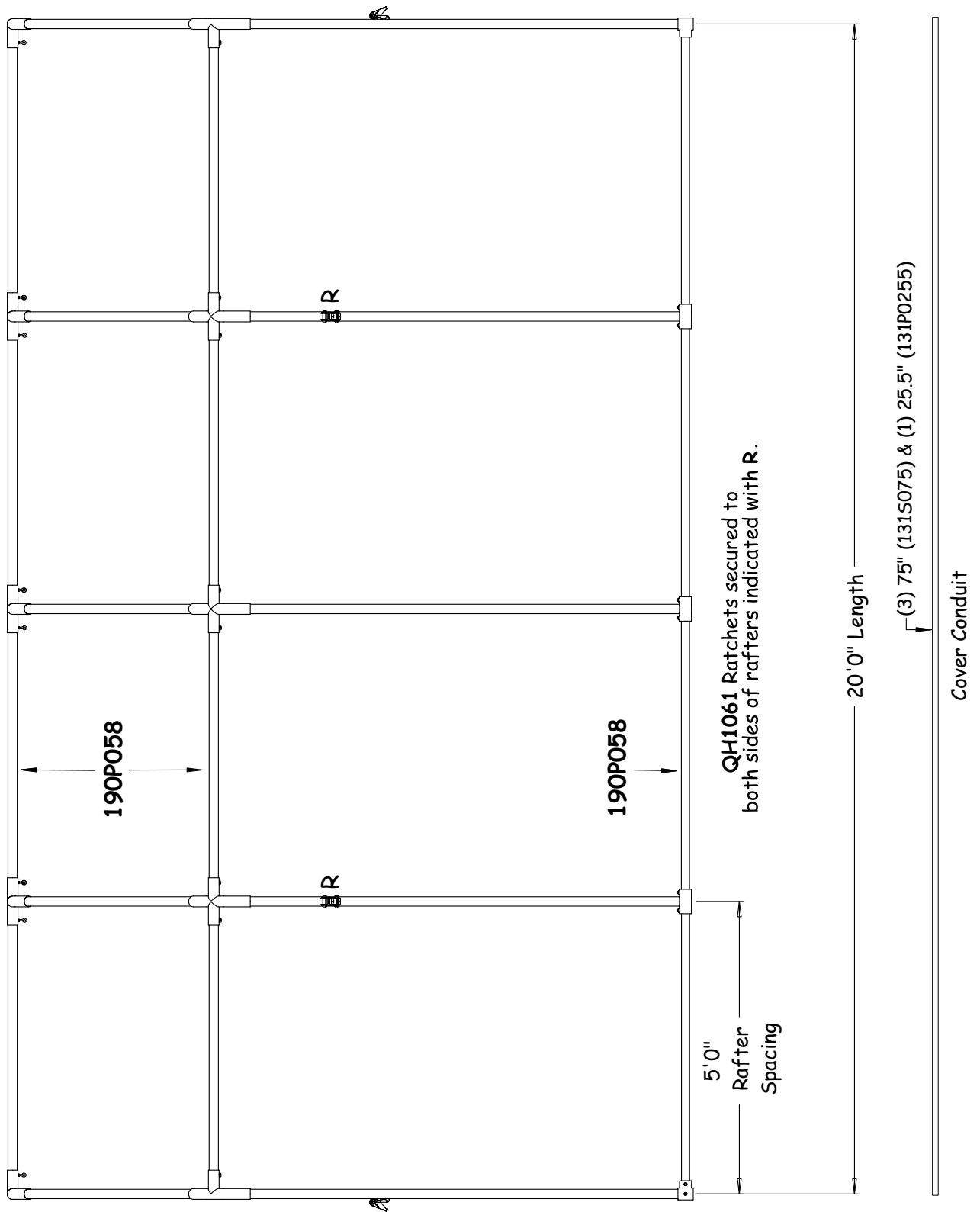

SIDE PROFILE - 107835

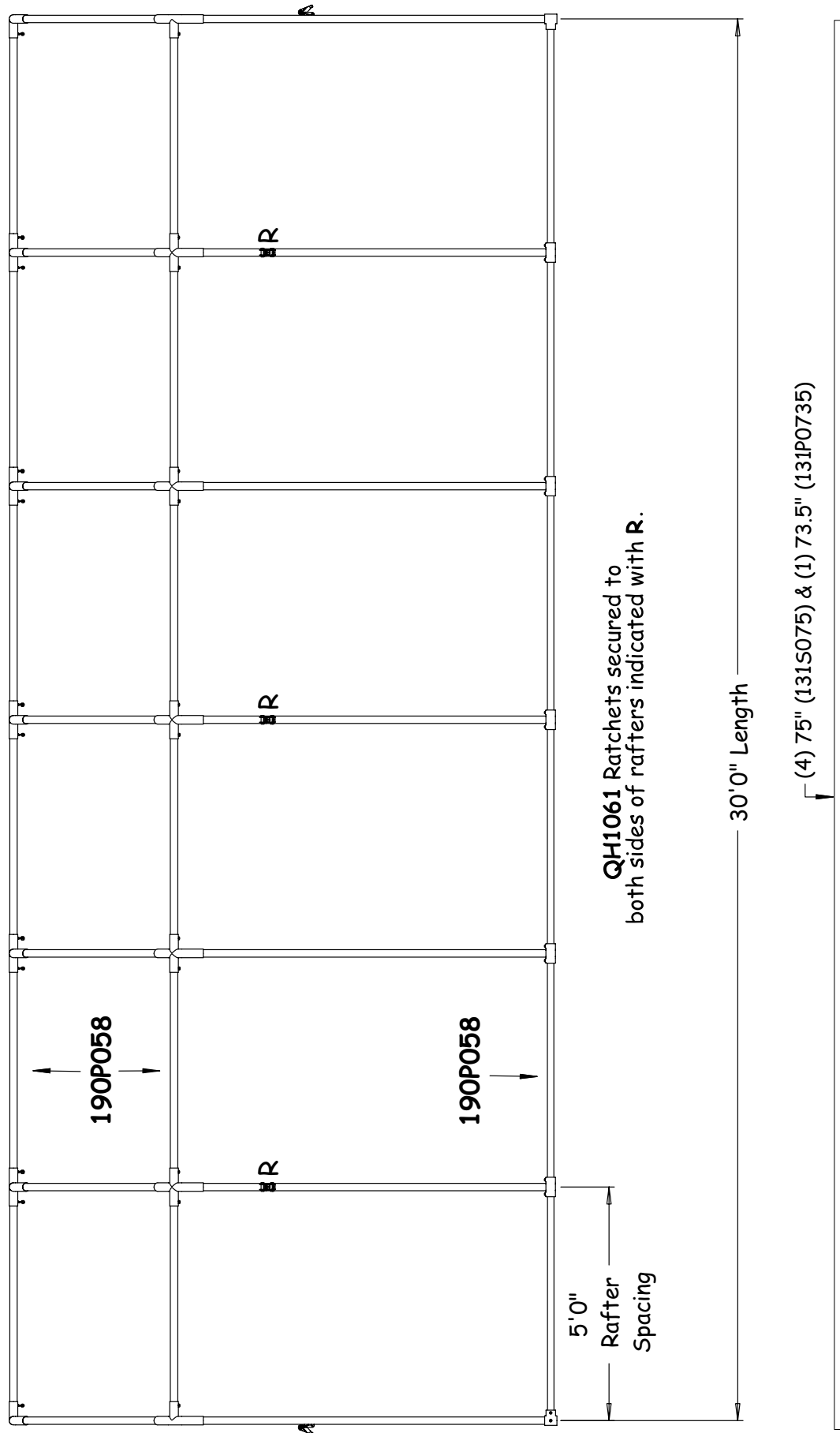

SIDE PROFILE - 107836

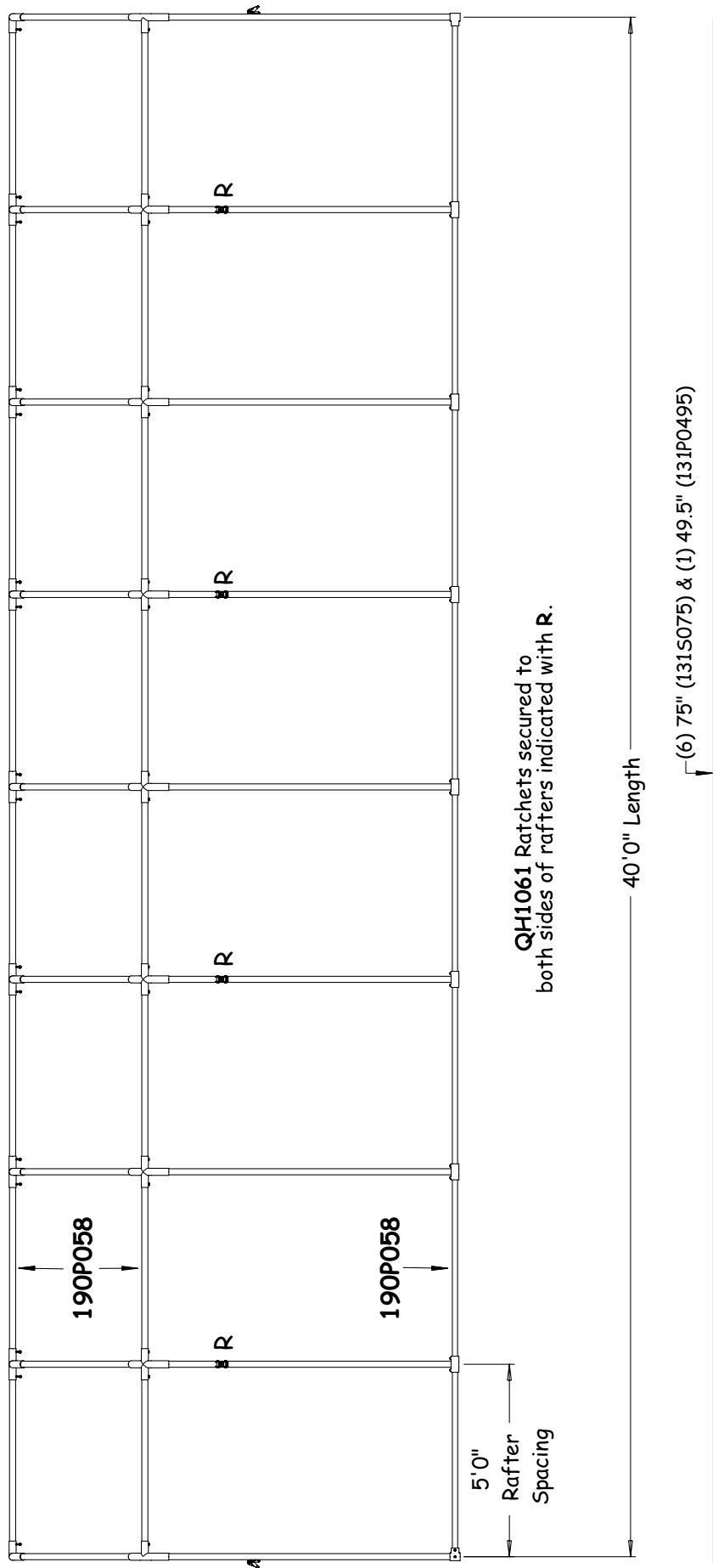

SIDE PROFILE - 107837

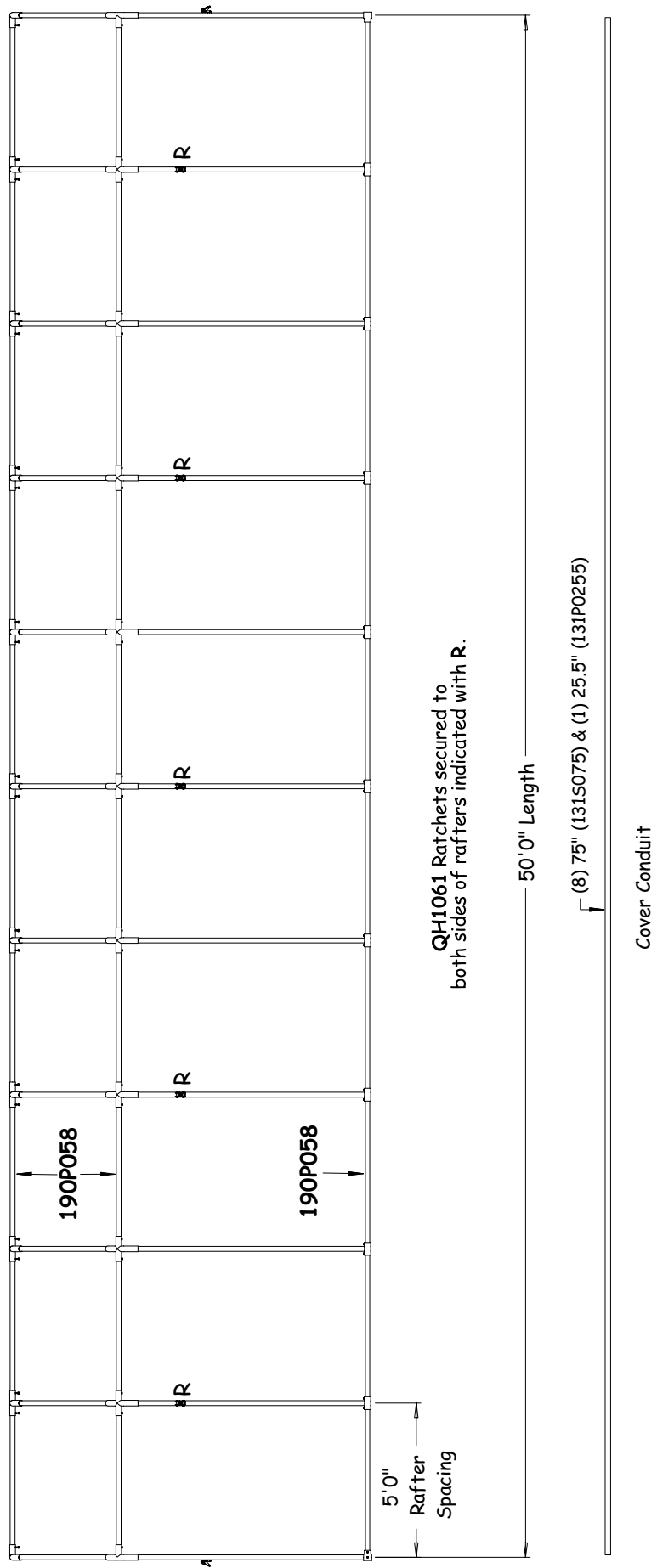

CONNECTIONS

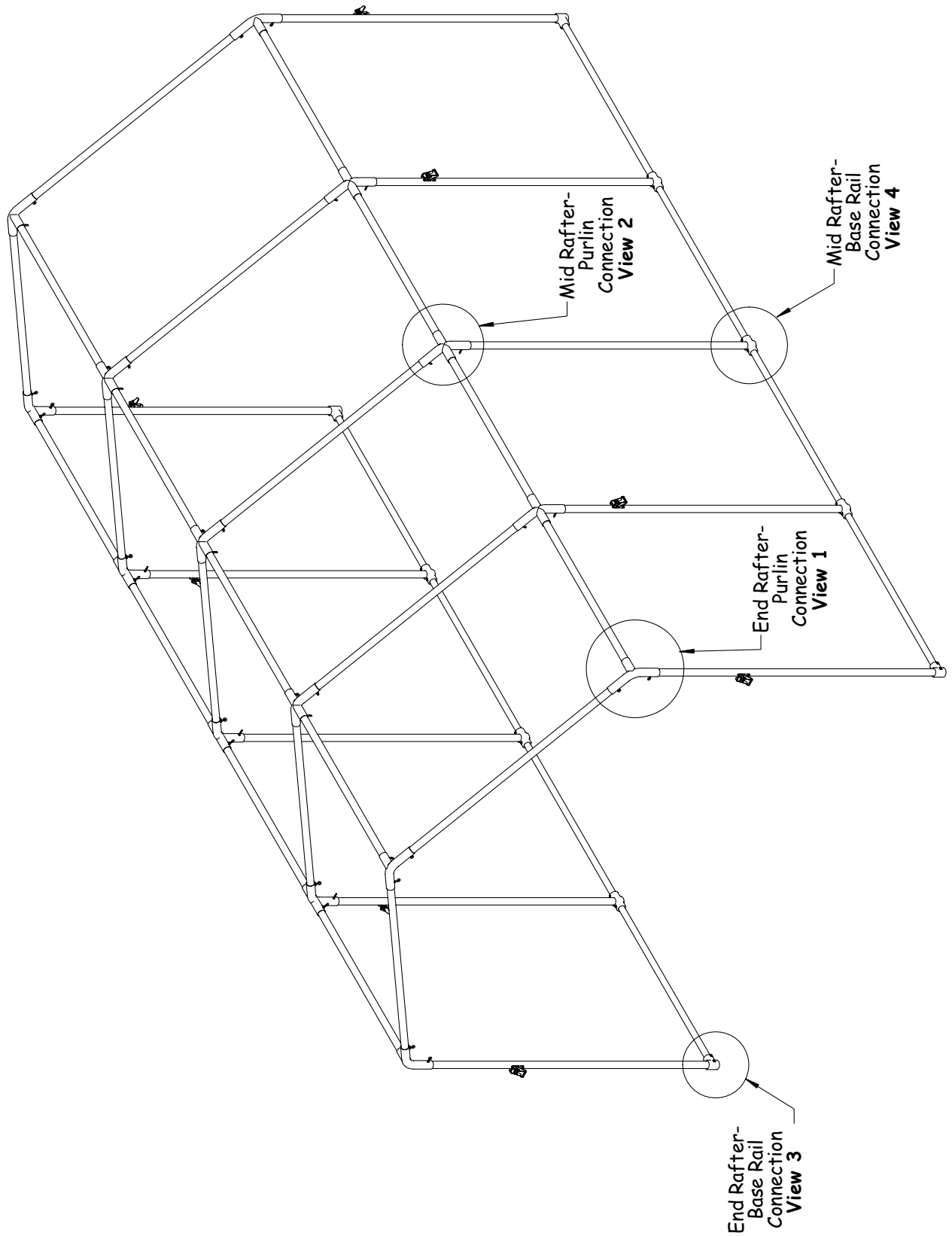

CONNECTION DETAILS

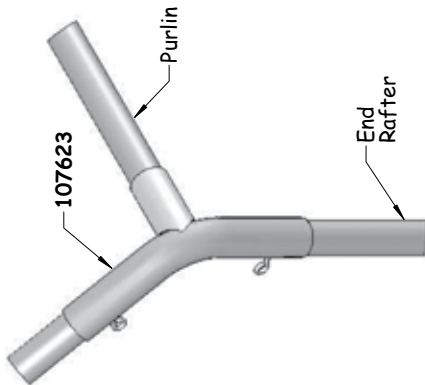

View 1
End Rafter-
Purlin
Connection

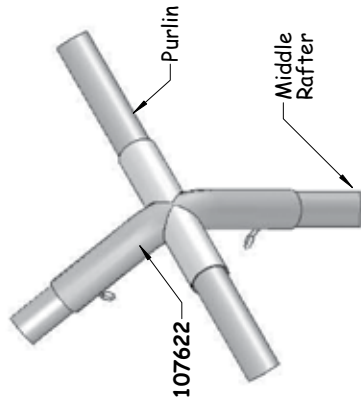

View 2
Mid Rafter-
Purlin
Connection

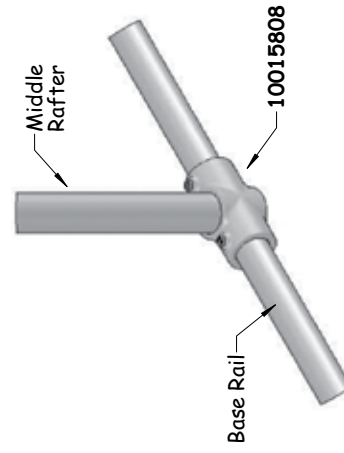

View 4
Mid Rafter-
Base Rail
Connection

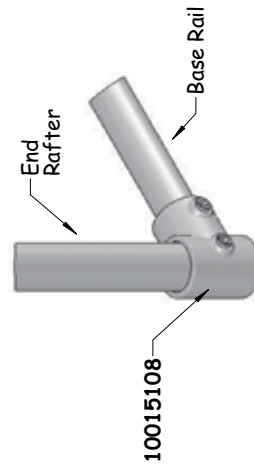

View 3
End Rafter-
Base Rail
Connection

ClearSpan



Space below is reserved for customer notes.