



**ClearSpan™ Carport**  
18' Wide (Small and Medium)



*Photo may show a different but similar model.*

©2007 ClearSpan™  
All Rights Reserved. Reproduction  
is prohibited without permission.

STK#	DIMENSIONS
104968F	18' W x 20' L
104969F	18' W x 25' L
104970F	18' W x 30' L
104971F	18' W x 35' L
104972F	18' W x 40' L
104973F	18' W x 45' L

Revision date: 12.26.07



### YOU MUST READ THIS DOCUMENT BEFORE YOU BEGIN TO ASSEMBLE THE SHELTER.

Thank you for purchasing this ClearSpan™ shelter. When properly assembled and maintained, this product will provide years of reliable service. These instructions include helpful hints and important information needed to safely assemble and properly maintain the shelter. Please read these instructions **before** you begin.

If you have any questions during the assembly, contact Customer Service for assistance.

### SAFETY PRECAUTIONS

- Wear eye protection.
- Wear head protection.
- Wear gloves when handling metal tubes.
- Use a portable GFCI (Ground Fault Circuit Interrupter) when working with power tools and cords.
- Do not climb on the shelter or framing during or after construction.
- Do not occupy the shelter during high winds, tornadoes, or hurricanes.
- Provide adequate ventilation if the structure is enclosed.
- Do not store hazardous materials in the shelter.
- Provide proper ingress and egress to prevent entrapment.

### ANCHORING INSTRUCTIONS

Prior to assembling this shelter, please read the **MUST READ** document included with the shipment.

**⚠ WARNING:** The anchor assembly is an integral part of the shelter construction. Improper anchoring may cause shelter instability and failure of the structure. Failing to anchor the shelter properly *will void the manufacturer's warranty* and may cause serious injury and damage.

### LOCATION

Choosing the proper location is an important step before you begin to assemble the structure.

The following suggestions and precautions will help you determine whether your selected location is the best location.

- Never erect the structure under power lines.
- Identify whether underground cables and pipes are present *before* preparing the site or anchoring the structure.
- Location should be away from structures that could cause snow to drift on or around the building.
- Do not position the shelter where large loads such as snow and ice, large tree branches, or other overhead obstacles could fall.

### SITE

After choosing a location, proper preparation of the site is essential. The following site characteristics will help ensure the integrity of the structure.

- A level site is required. The site must be level to properly and safely erect and anchor the structure. If the site is not level, construct footings to provide a secure base to assemble the structure. Pre-cast concrete blocks, pressure-treated wood posts, or poured footings are all acceptable when properly used.
- Drainage: Water draining off the structure and from areas surrounding the site should drain away from the site to prevent damage to the site, the structure, and contents of the structure.

**⚠ WARNING:** The individuals assembling this structure are responsible for designing and furnishing all temporary bracing, shoring and support needed during the assembly process. For safety reasons, those who are not familiar with recognized construction methods and techniques must seek the help of a qualified contractor.

## ASSEMBLY PROCEDURE

Following the instructions as presented will help ensure the proper assembly of your shelter. Failing to follow these steps may result in an improperly assembled and anchored shelter and will void all warranty and protection the owner is entitled.

The steps outlining the assembly process are as follows:

1. Verify that all parts are included in the shipment. Notify Customer Service for questions or concerns.
2. Read these instructions, the Must Read document, and all additional documentation included with the shipment **before** you begin assembling the shelter.
3. Gather the tools, bracing, ladders (and lifts), and assistance needed to assemble the shelter.
4. Check the weather **before** you install the roof cover and any panels (if equipped). Do not install covers or panels on a windy or stormy day.
5. Re-evaluate the location and site based on the information and precautions presented in the documentation included with the shipment.
6. Lay out the site (if this has not been completed).
7. Assemble the frame components in the order they are presented in these instructions.
8. Assemble the frame including the struts (if equipped).
9. Consult the Must Read document for anchoring comments and instructions.
10. Assemble and install the cable assemblies (if equipped). These are typically found on larger shelters. Your shelter may include struts or other methods of bracing attached during the frame assembly procedure. (Some shelters do not require cables or struts.)
11. Install, tighten, and secure the end panel (if equipped) and main cover. This applies to fabric covers that stretch over the frame assembly. *Your shelter may include roof panels or side panels or both.*
12. Read the Care and Maintenance information at the end of these instructions.
13. Complete and return all warranty information as instructed.

## LIST OF WORDS AND PHRASES

Before you begin, it is important to become familiar with the words and phrases used in this instruction manual.

These words and phrases are common to most ClearSpan™ shelters and identify the different parts of the shelter. (Some are used in this document. Others may not apply to this particular shelter.)

These terms describe the shipped parts and can also be found on the materials list/spec sheets included with the shipment. To aid in the assembly, read through the following definitions before you begin to assemble your shelter.

- **Conduit:** An assembly of pipes used to secure the main cover and end panels (if equipped). Purlins and some strut assemblies also consist of connected pipes to form a conduit. Each pipe joint of a conduit assembly is secured with a self-tapping Tek screw.
- **Coupler or Fitting:** A part of the frame assembly where legs, purlins and rafter pipes are inserted and secured. In most instances, 3-way and 4-way couplers are used. In some larger applications, couplers are used to secure the joints of the different rafter sections during the assembly of the rafters. Some shelters do not use couplers.
- **Foot or Rafter Foot:** The part attached to and found at the base of the rafter or leg of the shelter. Depending on the shelter, the foot is an optional purchase. Some shelters do not offer an optional foot. Some use 1-way connectors.
- **Must Read Document:** This document includes building and shelter anchoring instructions, steps for end wall reinforcement, safety precautions, and notices and warnings. The Must Read document is sent with all shelters and buildings. If you did not receive a Must Read document, contact Customer Service to request one.
- **On-Center:** Term used to describe a measurement taken from the vertical center of the rafter or frame member to the vertical center of another.
- **Purlin:** The pipe assembly that runs perpendicular to the rafters or framework that supports the main cover. Purlins are found on the sides and roof areas of the assembled frame, are evenly spaced, and typically run from the front to the back of the shelter.
- **Plain or Straight Pipe:** A term used to describe a pipe that has the same diameter or width throughout its entire length.
- **Strut:** A strut is usually a length of pipe with two flattened ends and is used for diagonal bracing of the shelter frame. A strut is typically secured to the frame work by special brackets and bolts.
- **Swaged End or Swaged Pipe:** The term "swaged" refers to the tapered end of the pipe or tube. Swaged ends of a pipe can be inserted into couplers and the straight ends of other pipes.
- **Tek Screw:** A self-tapping fastener used to secure pipe joints and to fasten brackets to rafters.

# CLEARSPAN™ CARPORTS

## REQUIRED TOOLS

The following list identifies the main tools needed to assemble the shelter. Additional tools and supports may be needed depending on the structure, location, and application.

- Tape measure or measuring device
- Chalk line (optional)
- Marker to mark locations on the pipes
- Variable speed drill and impact driver (cordless with extra batteries works best)
- Metal-cutting tool for pipe
- Wrench, ratchet and socket (recommended)
- Hammers and gloves
- Ladders, work platforms, and other machinery for lifting designed to work safely at the height of the shelter



Space below is reserved for customer notes.

## UNPACK AND IDENTIFY PARTS

The following steps will ensure that you have all the necessary parts before you begin to assemble the shelter.

1. Unpack the contents of the shipment and place where you can easily inventory the parts. Refer to the Bill of Materials/Spec Sheets.
2. Verify that all parts listed on the Bill of Materials/Spec Sheets are present. If anything is missing or you have questions, consult the Pictorial Parts Guide and all shelter diagrams for clarification, or contact Customer Service.

**NOTE:** At this time, you do not need to open the plastic bags containing the fasteners (if used).

## QUICK START GUIDE

For a quick overview of this shelter and its components, consult the Quick Start Guide at the back of these instructions.

# ClearSpan

The following graphics and photos will help you identify the different parts and show you how they are used.  
(Not all parts are shown.)



FA4482B  
Tek Screw



100441  
Nut Setter



104075  
1.75" x 1.75" Square  
Tube Insert

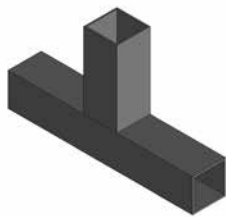

104626  
3-Way Square Tube  
Fitting

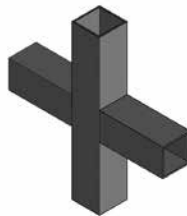

104627  
4-Way Square Tube  
Fitting

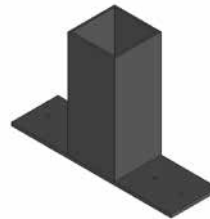

104624  
1-Way Square Tube  
Fitting w/ Plate

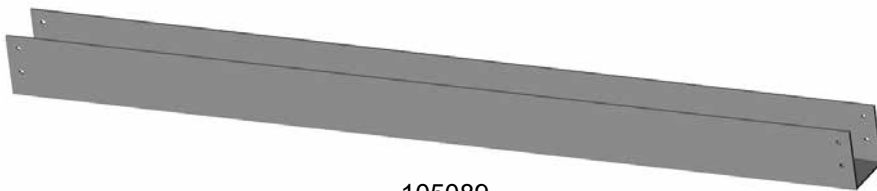

105089  
Carport Brace



## ClearSpan™ Carport 18' Wide (Small and Medium)

### OVERVIEW

This section describes assembling your carport frame. For details, please see section, Assembling the Carport Roof Frame Components. See illustration below to identify main parts of shelter.

1. Locate the required parts for each assembly procedure.
2. Assemble and position base rails.
3. Assemble rafters and frame.
4. Square and anchor carport.
5. Install struts and shelter bracing.
6. Install side and end panels (if equipped).
7. Attach main cover (if equipped).

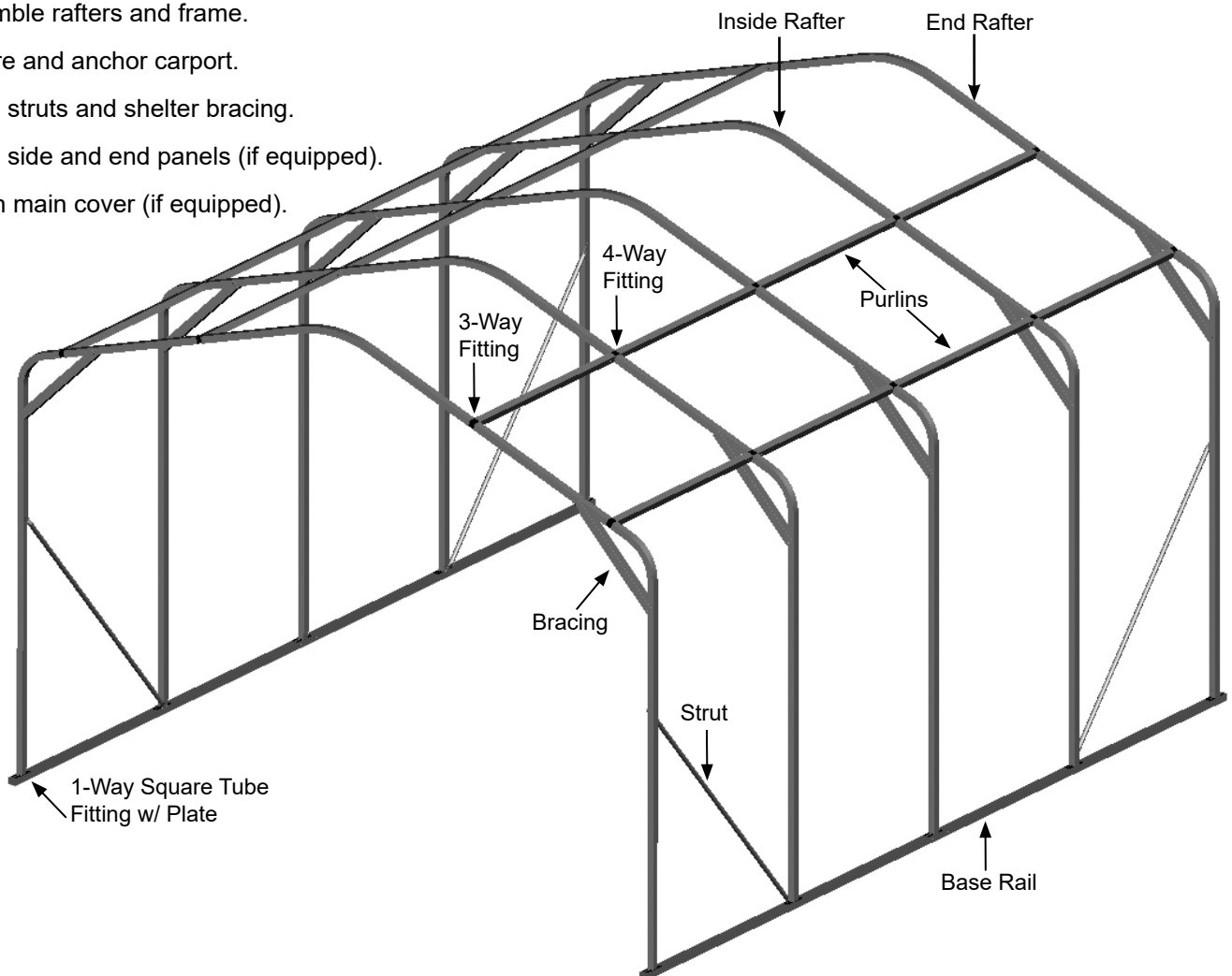

Diagram may show a different shelter length.

**LAY OUT THE BUILDING SITE**

After the site is prepared, marking the ground where the shelter will be situated and identifying the location of the shelter corners helps to square the frame after it is assembled.

Taking these steps **before** assembling the shelter saves time and ensures that the structure is positioned as desired. The following procedure is a suggested method. Its use depends on the size of the shelter, shelter application, the footings, and the method used to anchor the shelter.

This procedure may not be needed for shelters that include a base rail. It can be used, however, as a guide when positioning the frame on the site during assembly.

**SQUARE THE SITE**

1. Identify a corner where a building rafter or base rail will be positioned, drive in a stake, and string a line the exact width of the building and stake in place.
2. Sting a line at least as long as the building from the first stake at 90°.

**NOTE:** A transit can be used to ensure an accurate 90° angle, or the 3-4-5 rule can be used. Refer to diagram. Using multiples of 3-4-5 such as 6-8-10 or 12-16-20 helps to maintain an accurate 90° angle.

3. After squaring the position of the building and placing a stake at all corners, string a line between the stakes to mark the base of the building.

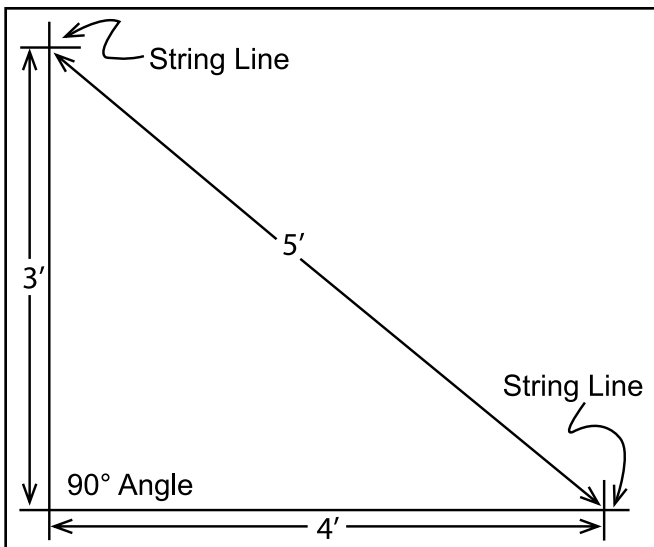

4. Continue with the base rail assembly procedures that follow.

**ASSEMBLE AND POSITION BASE RAILS**

**NOTE:** Assistance is required to assemble the carport frame.

Gather the parts:

- Square tubing (See chart below)
- 1.75" x 1.75" square tube insert (#104075)
- 1-way square tube fittings (#104624)
- Tek screws and nut setter 3/8" x 2-9/16 magnetic

The base rails consist of 2" x 2" square tubing and run the length of the building. The tubing is connected by a 16" square tube (1.75" x 1.75") insert. Each frame length has a different configuration of 2" x 2" square tubes.

Listed below are the shelter lengths and the needed tubing for one (1) base rail.

Shelter Length	Tubing Requirement
20'	124" & 124"
25'	(2) 124" & 60"
30'	(2) 124" & 120"
35'	(2) 124" & 120" & 60"
40'	(2) 124" & (2) 120"
45'	(2) 124" & (2) 120" & 60"

**ASSEMBLE BASE RAILS**

1. Locate your shelter in the table above and determine the required tubing for the two base rails.

**Example:** For a shelter that is 20' long, one base rail would require two (2) 124" tubes.

2. At each splice, insert the 1.75" x 1.75" square tube 8" into one of the 2" x 2" tubes and secure with two Tek screws.
3. Slide the remaining 2" x 2" tube onto the exposed portion of the insert and secure with Tek screws. See diagram below.

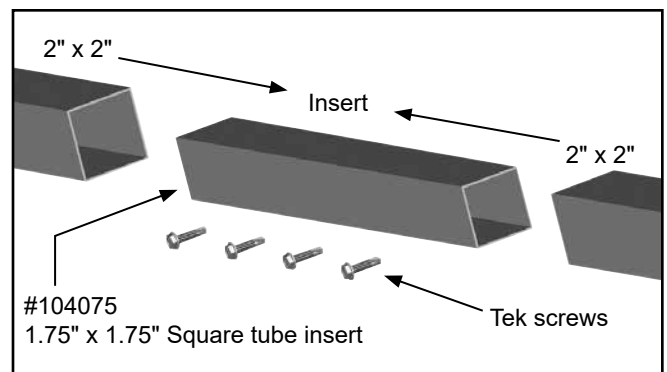

4. Repeat the steps for all base rail splices (if present) and for the remaining base rail.



## CLEARSPAN™ CARPORTS

### ASSEMBLE AND POSITION BASE RAILS (Continued)

Attach 104624 Fittings (Rafter Feet)

Gather the parts:

- Assembled base rails
- 1-Way square tube fittings (#104624)
- Tek screws and magnetic nut setter 3/8" x 2-9/16"
- Tape measure and marker

**NOTE:** Before attaching the 104624 square tube fittings, position the base rail so the heads of the Tek screws face the inside or the outside of the shelter.

*Do not position the rail with the Tek screws on the top or bottom of the rails. Doing so may interfere with the installation of the #104624 fittings for the rafters.*

1. After connecting the tubes of the two base rails, measure 4" in from one end of a base rail and mark the location.

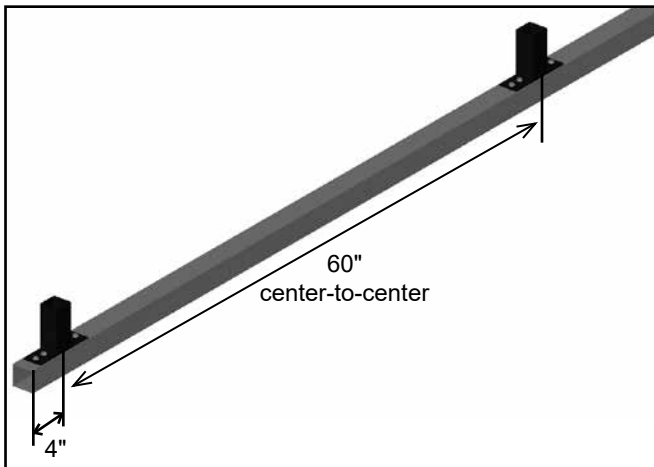

2. Beginning at the mark made in Step 1, measure 60" and mark a second line on the base rail.
3. Continue marking the base rail in 60" intervals. These marks represent the 5' on-center rafter positions.
4. Center the first square tube fitting (#104624) on the first mark and secure it to the top of the base rail using four (4) Tek screws as shown below.

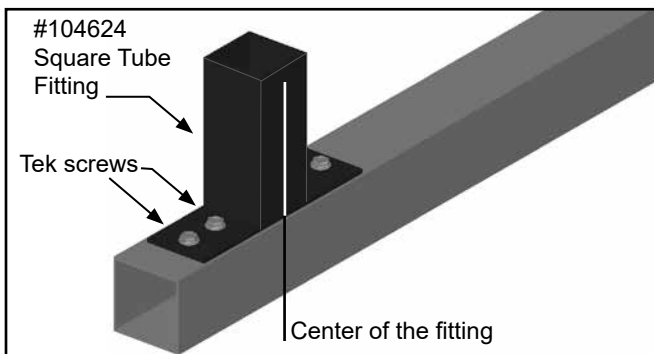

5. Center a square tube fitting (#104624) on each remaining mark and secure the fitting to the rail using Tek screws.

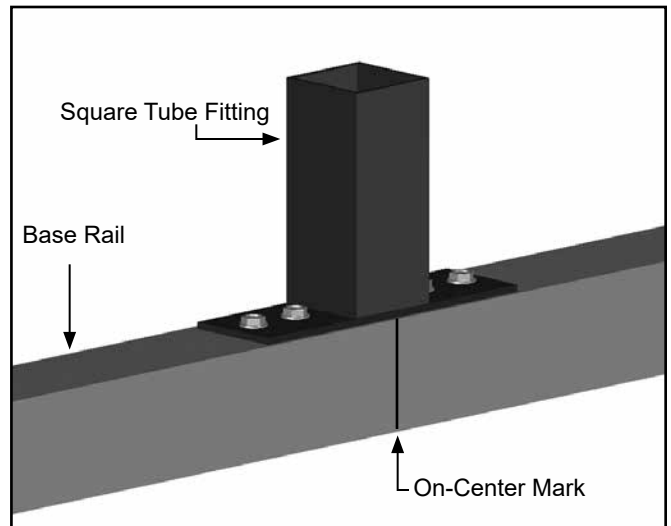

6. Repeat the steps for the remaining base rail.

**NOTE:** Rafter spacing is measured center-to-center.

7. Position base rails on the site where the shelter will be assembled. Space rails at the approximate width of the shelter.

**ATTENTION:** Do not anchor the rails to the site at this time.

8. After the base rails are assembled and positioned on the site, continue with the rafter assembly steps.



**RAFTER ASSEMBLY**

Gather the parts:

- Rafter pipe ( #12CP20P1) & rafter pipe (#18CP20P3)
- Rafter pipe (#S20P048)
- Rafter pipe (#S20P036): Medium frame only
- Carport brace (#105089)
- 3-way (#104626) and 4-way fittings (#104627)
- Tek screws and magnetic nut setter 3/8" x 2-9/16"

**Rafter Assembly Procedure**

Each rafter assembly consists of five (5) rafter tubes: one (1) curved center pipe (for the top or peak), two (2) bent leg pipes, and two (2) straight pipes between the peak and the bent leg pipes.

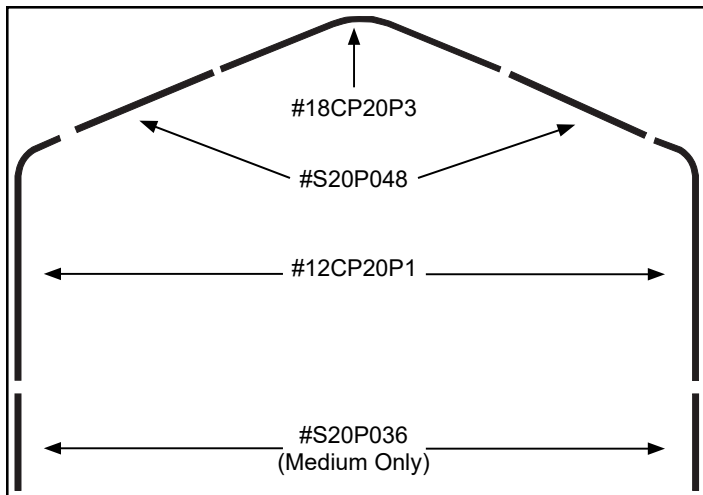

**ATTENTION** (medium frame only): Two (2) additional straight pipes are included. See the diagram above for clarification and tube locations.

**End Rafters**

Complete the following steps to assemble the two (2) end rafters.

**NOTE:** The two (2) end rafters are assembled using 3-way square tube fittings (#104626) positioned between the upper tube splices.

1. Select the tubes needed to assemble the rafter and place these on the ground as shown.

**NOTE (medium frame only):** The lower leg pipes (#S20P036) are 36" long. The upper (#S20P048) pipes are 48" long. *Measure the pipes if needed to install in the correct location.*

2. Insert the 3-way square tube fittings (#104626) into the rafter pipes as shown below and secure them using Tek screws.

The free end of each 3-way square tube fitting (#104626) *must face the same direction*. The free section of the tube fitting is used to connect the purlin pipes and the next rafter.

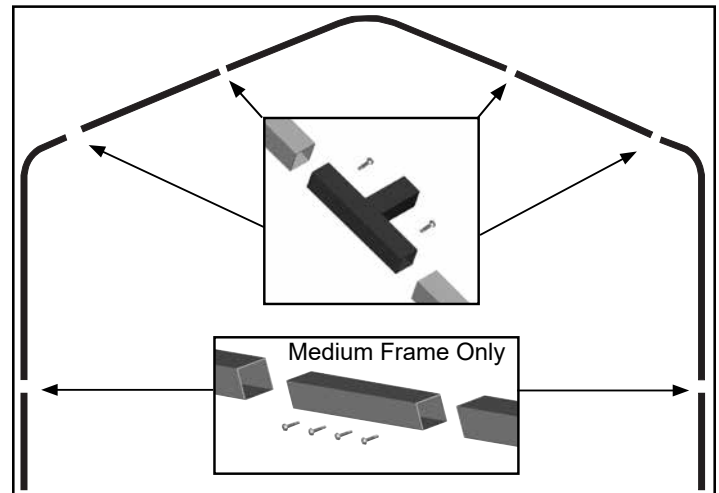

**IMPORTANT:** To prevent damage to the roof panels or cover, position the Tek screws so the heads do not contact the roof when installed.

**Medium Frame Only:** Connect the lower rafter legs using the 1.75" x 1.75" square tube insert (#104075). (See the Base Rail assembly steps if needed.) Place the insert 8" into the rafter pipes and secure using Tek screws.

3. Repeat steps for the remaining end rafter.

**NOTE:** There are two (2) end rafter assemblies.

## CLEARSPAN™ CARPORTS

### RAFTER ASSEMBLY (continued)

#### Interior Rafters

1. Select the tubing for the *first interior rafter assembly* and position it on the ground as previously described.
2. Install a 4-way square tube fitting (#104627) in the locations shown in the diagram below and secure the joints using Tek screws.



Space below is reserved for customer notes.

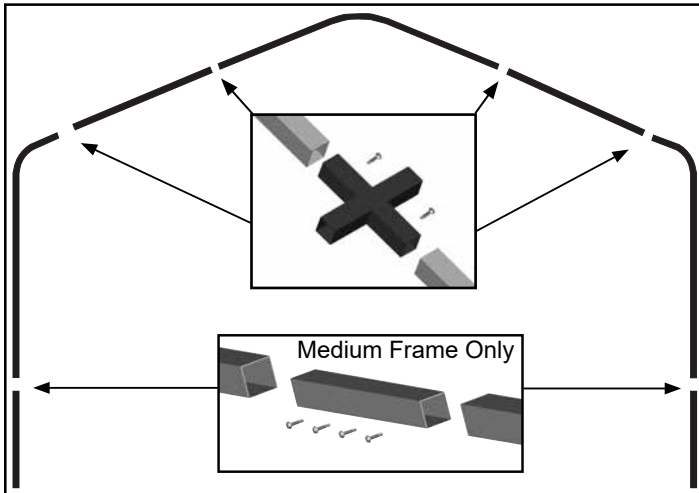

**IMPORTANT:** To prevent damage to the cover, install Tek screws so the heads do not contact the roof panels when these are installed.

**Medium Frame Only:** Connect the lower rafter legs using the 1.75" x 1.75" square tube insert (#104075). (See the Base Rail assembly steps if needed.) Place the insert 8" into the rafter pipes and secure using Tek screws.

3. Repeat the steps for all remaining interior rafters.
4. Once all rafter assemblies are complete, continue with the frame assembly instructions that follow.

**FRAME ASSEMBLY**

The following instructions assume the 104624 fittings (rafter feet) are properly spaced on each base rail.

**ATTENTION:** If the site is not level as recommended, you must take the necessary steps to level the site before continuing. The frame will not assemble properly without a level site.

Gather the parts:

- Rafter assemblies and assembled base rails
- 58" square tubes (#S20P058)
- Tek screws and magnetic nut setter 3/8" x 2-9/16"

1. Stand the first end rafter and place the leg pipes on the first set of 104624 fittings on the base rails.

**NOTE:** Point the free ends of the 3-way fittings toward the next rafter position.

2. Anchor the end rafter with ropes or other temporary bracing. *Verify that the rafter is plumb (straight).*

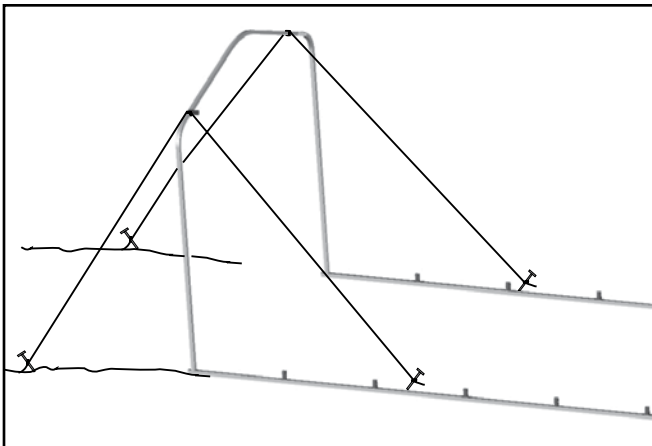

**NOTE:** In the above diagram, ropes (identified by black lines for clarity) are used to temporarily anchor the rafter in place. *Frame shown may differ from actual frame.*

For this first end rafter, all temporary bracing *must remain* in place until other rafters are set and attached to the first rafter and each other.

3. Secure each rafter leg tube to each 104624 fitting using one Tek screw as shown below.

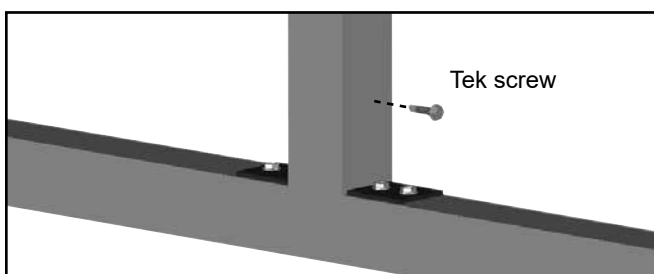

4. Carefully stand the first *interior rafter* and place the leg pipes on the next set of 104624 square tube fittings.
5. Secure the rafter leg tubes to the fittings using Tek screws as previously described.
6. Slide a 58" square tube (#S20P058) onto the 3-way fittings of the *end rafter* and secure each with a Tek screw.

**NOTE:** Verify that the screw head will not touch the cover when it is installed (if equipped).

7. Place the free end of each purlin onto the 4-way fittings of the second rafter, which is the first interior rafter.
8. Measure 60" from the center of the end rafter to the center of the second rafter. Adjust the rafter forward or backward to achieve the dimension.
9. When the dimension between the rafter peaks is achieved, secure the purlins to the 4-way fittings of the interior rafters using Tek screws.
10. Verify that all rafters are plumb and continue with the next step.
11. Continue to stand, place, and secure the remaining rafters to the base rails to complete the assembly of the frame.

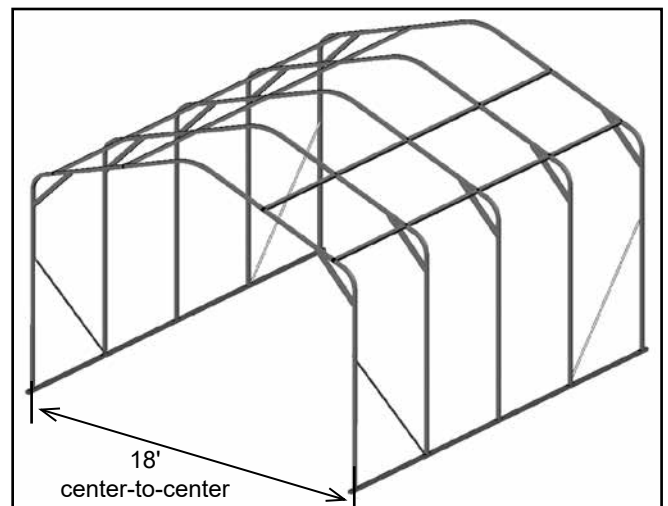

Frame shown may differ from actual frame. It is used for illustration only. Struts and bracing are installed later in this manual.

12. Once all rafters are set and all purlins are in place and secured to the 3-way and 4-way fittings, remove the temporary bracing (if needed), and square the assembled frame.

## CLEARSPAN™ CARPORTS

### SQUARE THE ASSEMBLED FRAME

Complete these steps:

1. Perform a final square of the frame by measuring diagonally (corner-to-corner) at the base and verify that the two measurements are equal.

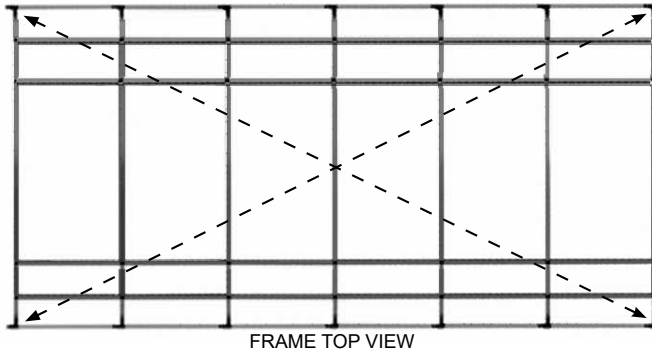

2. Examine the frame and remove any sharp edges from the frame or reposition screws so they do not come in contact with the roof panels (if equipped).
3. Verify that rafters are plumb and the width between the base rails is 18' on-center.
4. Verify that all pipe and tube joints are secured with Tek screws. *This includes base rails, rafters, purlins, and all additional bracing.*
5. After the frame is squared, read or reread the **MUST READ** document and anchor the frame in place.

### ANCHOR THE SHELTER

At this point in the assembly process, anchor the assembled frame. Once the frame assembly is anchored properly, continue with these instructions.

**⚠ WARNING:** Securing the base rails to concrete blocks or wood boards set on the site is not a substitute for properly anchoring the shelter. *You must anchor the shelter as described in the MUST READ document.*

FAILING TO PROPERLY ANCHOR THE SHELTER WILL RESULT IN DAMAGE TO THE SHELTER AND MAY CAUSE PERSONAL INJURY.

READ THE MUST READ DOCUMENT TO PROPERLY ANCHOR THE SHELTER.

The diagrams below illustrate two possible ways to properly anchor the shelter to the site.

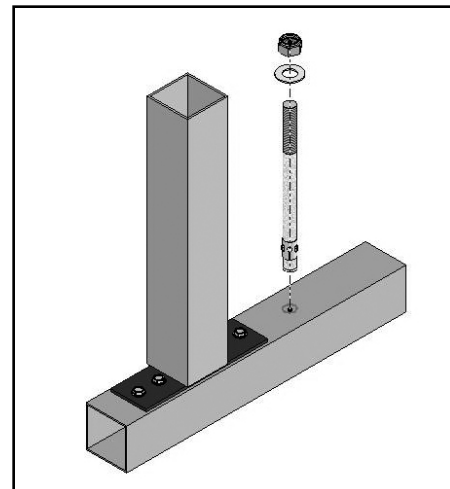

Anchor System for use on concrete

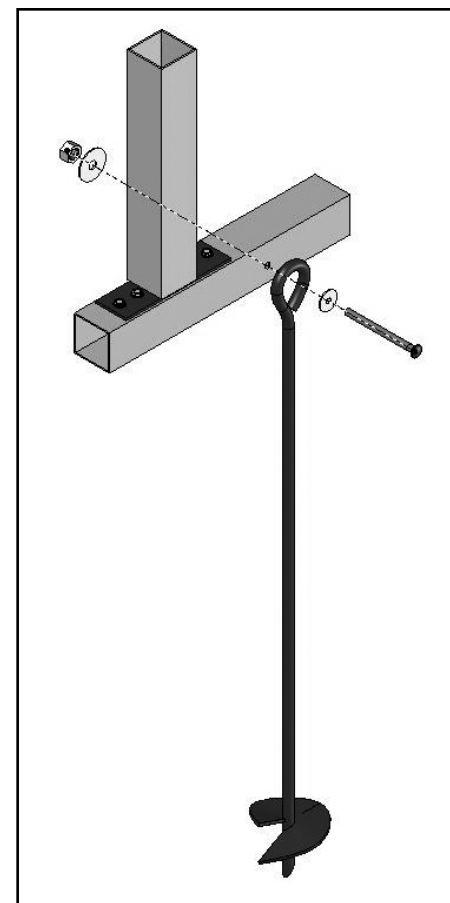

Ground Anchor System

The parts shown in the diagrams regarding anchor systems are *not included* with the shelter.

Contact Customer Service at 1.800.245.9881 to purchase additional parts to anchor the shelter.

**SIDE STRUT INSTALLATION**

Gather the parts:

- Struts (#105119)
- Tek screws

Complete these steps to install the four (4) side struts:

1. Locate one (1) eight foot strut and position it between one end rafter leg and the leg of the first interior rafter on the inside of the assembled frame as shown below.

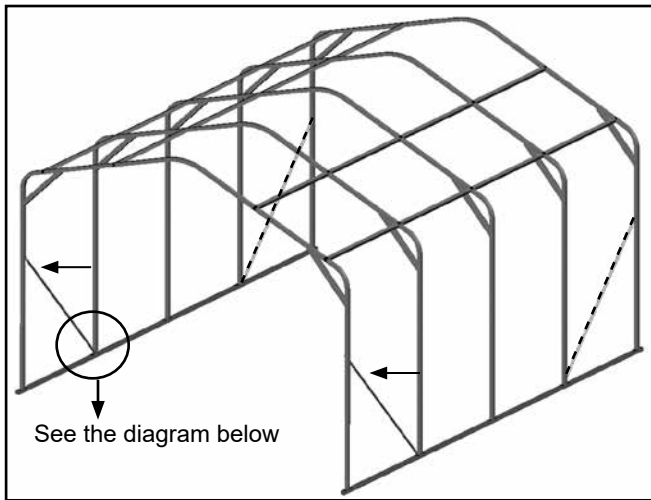

2. Align one end of the strut with the center of the interior rafter leg and *secure the strut to the base rail with a Tek screw*. See the diagram that follows for clarification.

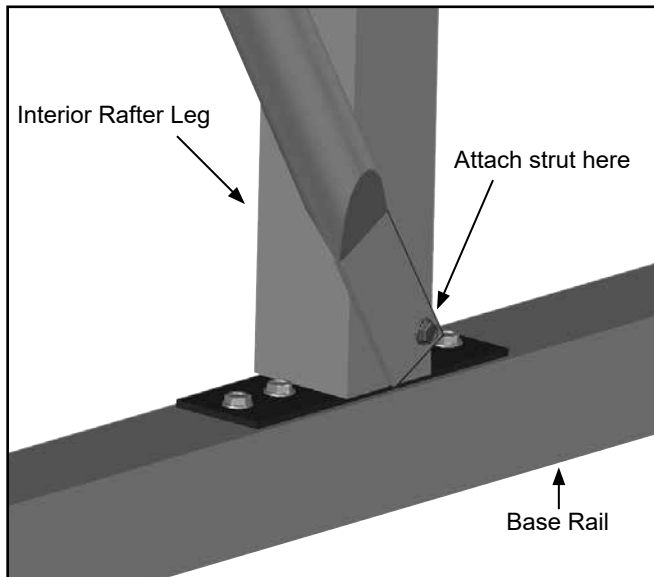

3. Verify that the end rafter is plumb (straight up and down) and *secure the top of the strut to the inside of the end rafter leg*.
4. Repeat the steps to attach the remaining side struts to the shelter frame.
5. After securing the four (4) struts, complete the next procedure to install shelter bracing.

**INSTALL SHELTER BRACING**

The diagonal shelter bracing is installed *after* the frame is squared and anchored and *before* installing the optional panels and/or main cover.

Gather the parts: Bracing (#105089) and Tek screws

Complete these steps to install the diagonal bracing for the shelter.

1. Locate one (1) three-foot (3') brace and place it into position as shown below.

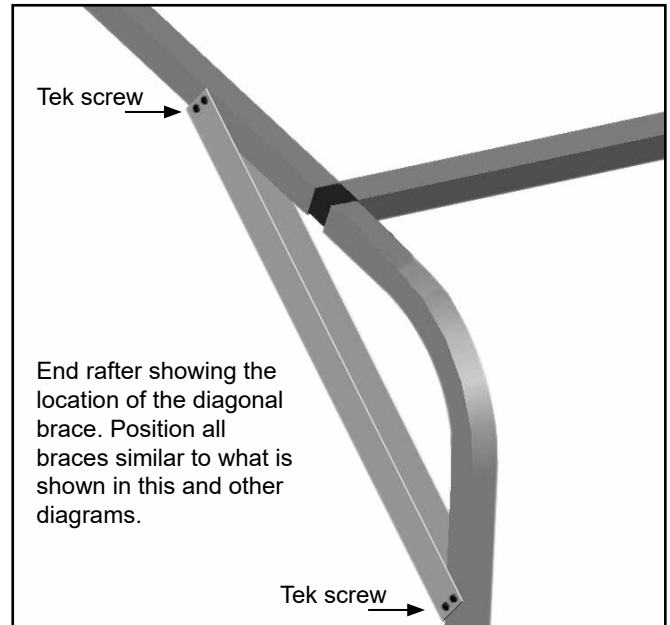

**NOTE:** Before attaching the brace to the rafter leg, verify that the rafter is plumb (side-to-side and front-to-back).

2. Secure the brace to the rafter using Tek screws as shown above.
3. Repeat the procedure for the remaining diagonal rafter braces.

**NOTE:** To keep all diagonal bracing consistent throughout the frame, measure the location of the first brace and duplicate that measurement for the remaining braces.

4. After all diagonal bracing is installed and secured to the assembled frame, continue with the following instructions.

## CLEARSPAN™ CARPORTS

### INSTALL OPTIONAL PANELS (if equipped)

Side panels are available for the shelter and provide additional protection from the elements and other sources that could damage the contents of the shelter. If your shelter includes the optional side panels, install these *before* the main cover is installed.

To purchase the optional side panels for your shelter, contact Customer Service at 1.800.245.9881 for additional information. If you do not have side panels to install, continue with the Ratchet and Main Cover Installation procedures (if equipped).

**⚠ WARNING:** To prevent serious personal injury or property damage, DO NOT install the cover on a windy or stormy day. For longer shelters, additional help is needed to lift and hold the panels in position.

### OPTIONAL INSTALLATION - END and/or SIDE PANELS

If the shelter includes the optional side panels and/or gable end panels, these panels MUST be attached to the frame *before* the cover is installed. If the shelter does not include the optional panels, continue with the main cover installation (if equipped).

**NOTE:** Optional gable ends and side panels are attached to the frame with the ball tie downs in the manner illustrated. Secure the panels to the frame before installing the main cover.

1. Unpack panels and unfold completely.
2. Take the snigger ball tie downs, feed the stretch cord through a grommet, and attach the main cover to the assembled frame. Use one snigger ball for each grommet.

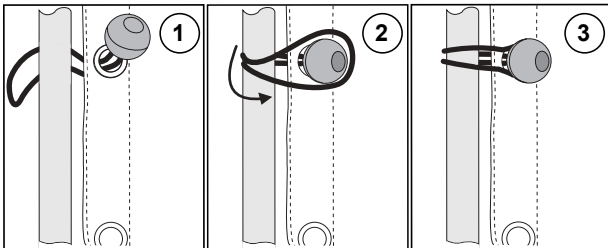

**NOTE:** A space will remain between the cover edge and the frame as shown in the diagrams.

If the installed side panel slides up or down, install a screw into the rafter below the upper snigger balls (shown to the left) to prevent the panel from sliding down, and above the lower snigger balls (not shown) to prevent the panel from sliding up the rafter leg or legs.

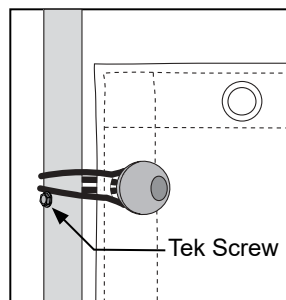

3. Install all side panels and/or gable end panels and continue with the main cover (if equipped).

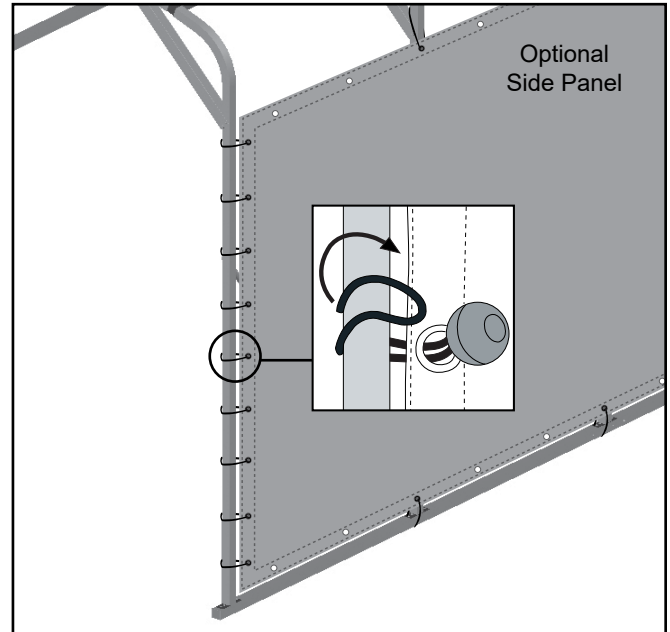

**⚠ WARNING:** Do not install panels without first anchoring the assembled frame.

### ALTERNATIVE SIDE PANEL INSTALLATION

The optional *main cover* (when it is installed) requires the installation of ratchets to the outside of specific rafters. In the main cover installation procedure that follows these side panel steps, the ratchets are installed after the side panels are attached. *As a result, ratchets are attached with Tek screws driven through the side panel and into the rafter.*

If desired, you can install the side panels on the *inside of the frame*. This will allow removal of the side panels without removing the ratchets that secure the main cover. Consult the diagram below.

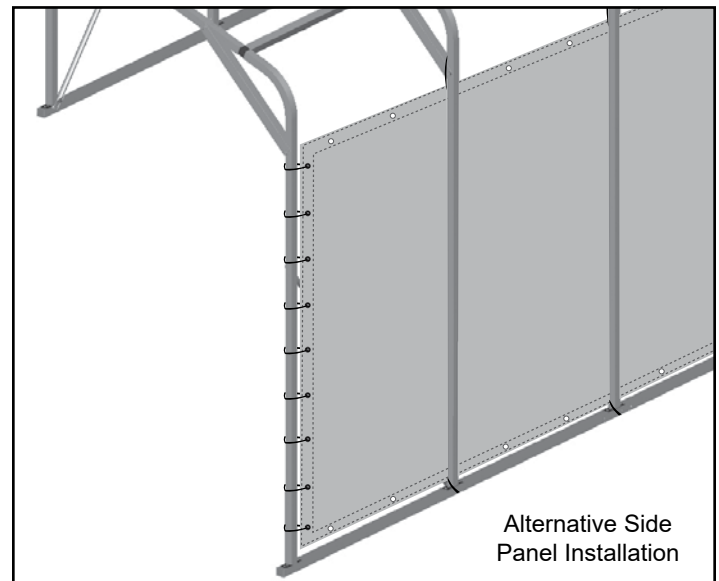



**INSTALL OPTIONAL MAIN COVER (if equipped)**

The main cover is secured to the frame using ratchets and straps. The straps are wrapped around a conduit inserted in a pocket along each side of the cover.

**NOTE:** Carports can be ordered with or without covers.

**⚠ WARNING:** To prevent damage to the cover and to prevent serious personal injury, **DO NOT** attempt to install the cover on windy days.

1. Locate the pipes for two (2) main cover conduits. *The assembled conduits are nearly the length of the shelter.*

**NOTE:** The number of pipes used in the cover conduit assembly varies with the length of the shelter.

Each cover conduit consists of 1.315" x 75" (#131S075) swaged pipes (number is determined by shelter length) and one (1) 1.315" x XX" (#131P0XX) plain pipe.

The "XX" represents the remaining length needed to reach the end of the frame.

2. Connect these pipes by inserting the swaged ends of the pipes into the plain ends until each conduit is assembled. Secure each pipe joint with a Tek screw and wrap the joint with duct tape.

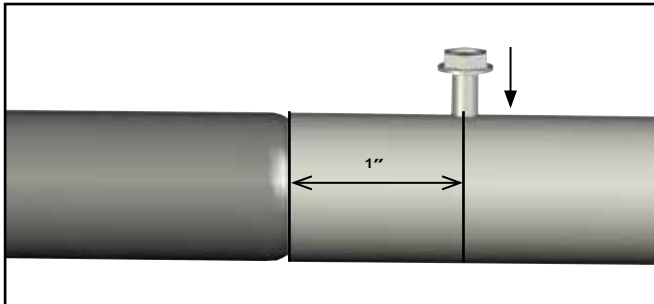

These cover conduits are inserted into the pockets sewn into the cover. The conduits are used to tighten and secure the cover.

3. After assembling the cover conduits, locate the cover and unfold it on a clean, smooth surface near the frame.

**NOTE:** When handling the cover and setting it in position, do not pull on the end straps. They will pull out of the cover. Unfold the cover with the inside surface facing up.

4. Locate the cover ends with strapping and align cover with the front and back of the shelter.

5. Insert the cover conduits into the pockets of the cover.

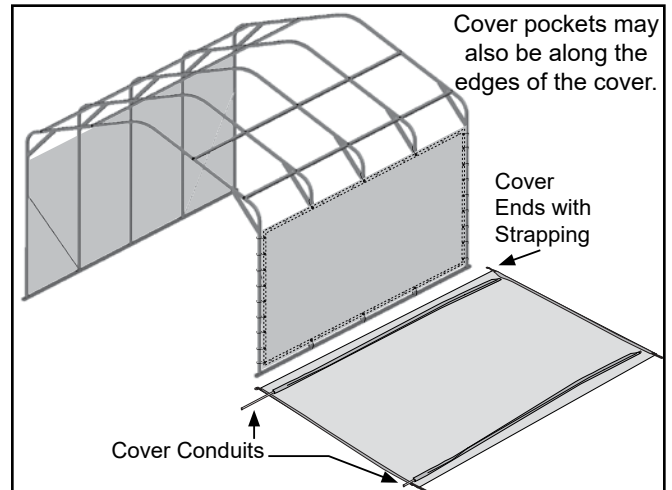

**NOTE:** Shelter shown above may differ in length from the actual model. Cover design may also differ.

6. To pull the cover over the frame, attach ropes to both ends of the cover conduit. Wrap the rope around the conduit a few times to prevent it from slipping off.

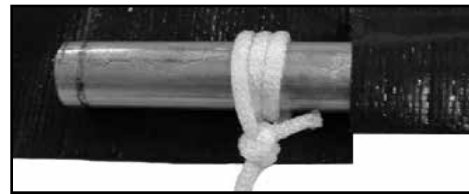

**NOTE:** Depending on the length of the cover it may be necessary to attach additional ropes to the cover conduit between the end ropes by cutting a small opening in the cover pocket and tying the rope around the conduit. **DO NOT** cut through the cover. *Cut through the conduit pocket only.*

7. With all ropes attached to the cover conduit, lift the conduit and carry the cover toward the base of the frame.
8. Toss the ropes over the frame and pull the cover into position. One person is required at each rope.
9. Center the cover front to back and side to side.

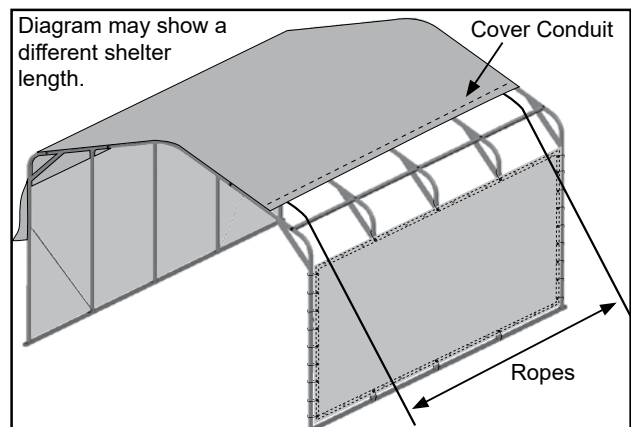

**ATTENTION:** Do not leave an unsecured cover unattended.



# CLEARSPAN™ CARPORTS

## INSTALL COVER (CONTINUED)

10. At the front and back cover hems, locate the black straps. Using the straps as guides, fasten ratchets to the outside of the end rafter legs using a Tek screw.

**NOTE:** Allow a few inches to remain between the end of the cover and the ratchet.

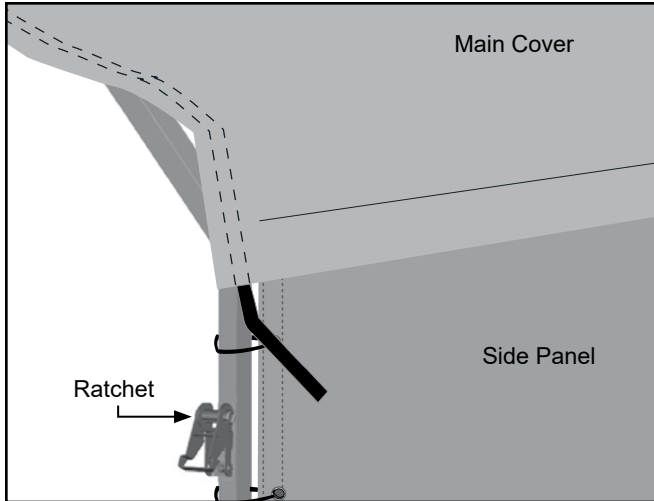

11. Thread the strap end into the ratchet and slightly tighten. *Do not tighten completely at this time.*

**NOTE:** It may be necessary to remove excess strap if it binds up in the ratchet.

12. Divide the remaining number of ratchets in half. Place the ratchets on the ground next to the rafter where they will be attached.

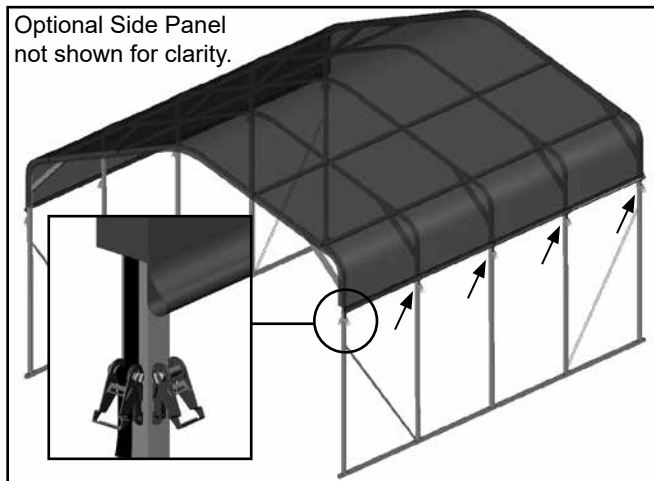

**NOTE:** Ratchets are evenly spaced long each side of the shelter and directly across from each other on the *same rafter assembly*.

Consult the Side Profile diagrams in the Quick Start section for ratchet location details.

13. Using the main cover conduit and strap length as guides, attach the ratchets to the rafters at the proper height. Fasten ratchets to the outside of the rafters using Tek screws.

If bulk strap is sent, attach ratchets 12"-16" below the main cover conduit.

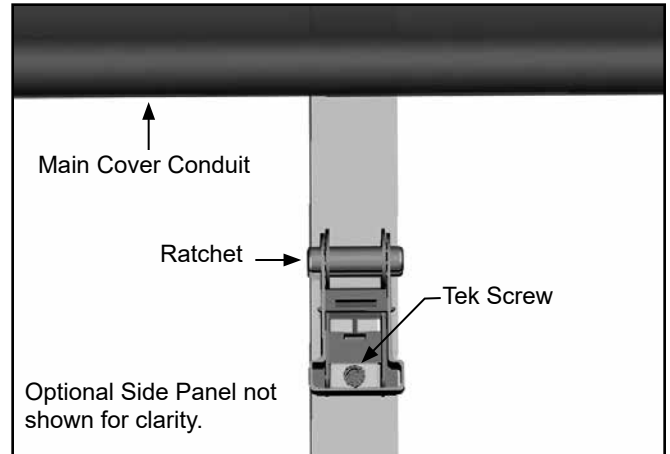

**NOTE:** Side ratchets are attached with Tek screws driven through the optional side panel (if equipped) and into the rafter.

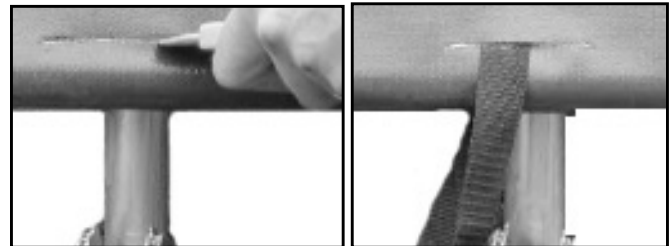

14. Cut a slit in the cover conduit pocket at the rafter position. Insert a section of strap through the slit and around the cover conduit.

**NOTE:** DO NOT cut through the main cover. *Cut through the conduit pocket only.* Photos may show a different rafter, procedures are the same.

15. Thread the strap ends into the ratchet and slightly tighten.

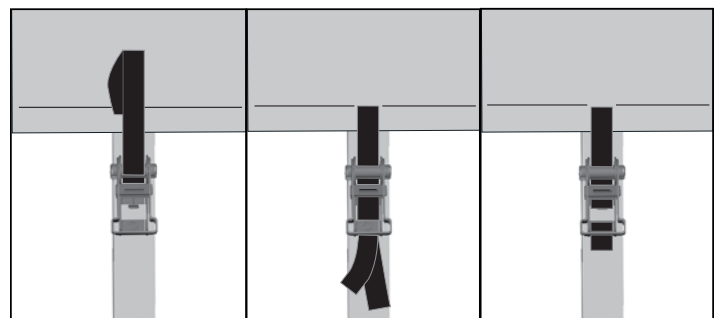

**NOTE:** It may be necessary to remove excess strap if it binds up in the ratchet.

**INSTALL COVER (CONTINUED)**

16. Repeat the steps for the remaining ratchets.
17. Using additional help (if needed) tighten the main cover beginning with the ratchets along the side of the shelter frame.
18. After the side ratchets are tightened, return to the end wall ratchets and tighten the bonnet straps of the main cover.

**NOTE:** Loosen the ratchets if needed to remove excess strap and retighten. Loosen all ratchets if needed to reposition the main cover on the frame and retighten the ratchets.

19. After the main cover is tight, read the **Shelter Care and Maintenance** information that follows.

**CARE AND MAINTENANCE**

Proper care and maintenance of your carport is important. Check the following items periodically to properly maintain your carport:

- Frequently inspect building and all components.
- Replace damaged or worn parts promptly.
- Regularly check the roof panels to see that they remain tight and in proper repair.
- Check connections and all fasteners to verify that they remain tight.
- Verify that the anchor system used to secure the assembled frame to the site is in good repair and that all connections and fasteners are tight.
- Do not climb or stand on the shelter at anytime.
- Remove debris and objects that accumulate on the shelter. Use tools that will not damage the roof panels when removing debris.
- Remove snow to prevent excess accumulation. Use tools that will not damage the roof panels when removing snow.
- Check the contents of the shelter to verify that nothing is touching the roof panels that could cause damage.
- If side or end panels are present, verify that they remain tight and in good repair.
- If the shelter is moved, inspect all parts and connections before using.
- For replacement or missing parts, call 1.800.245.9881 for assistance.

**NOTE:** With the exception of Truss Arch buildings, ClearSpan™ shelters and greenhouses *do not* have any tested loading criteria.



Space below is reserved for customer notes.

# ClearSpan

## QUICK START GUIDE

18' Wide Carport  
(Small and Medium Frame)

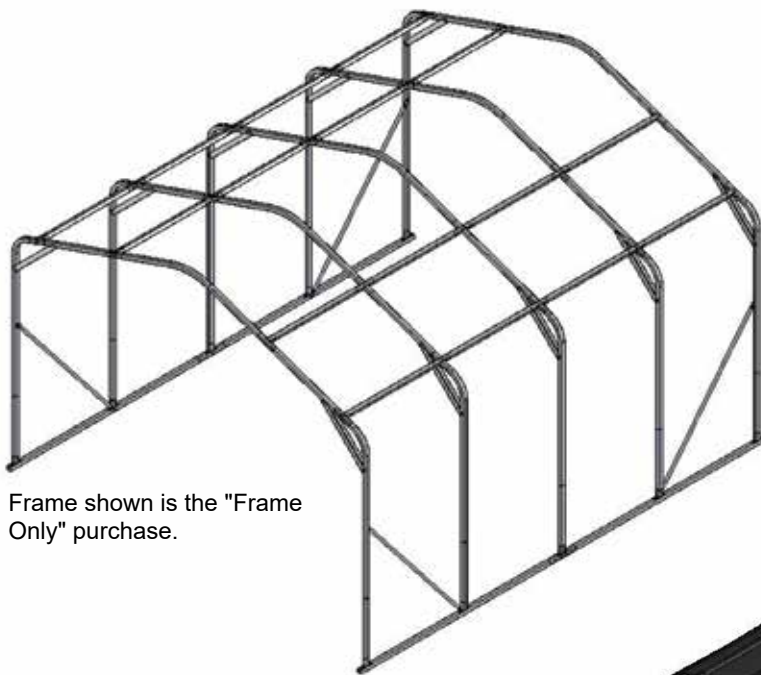
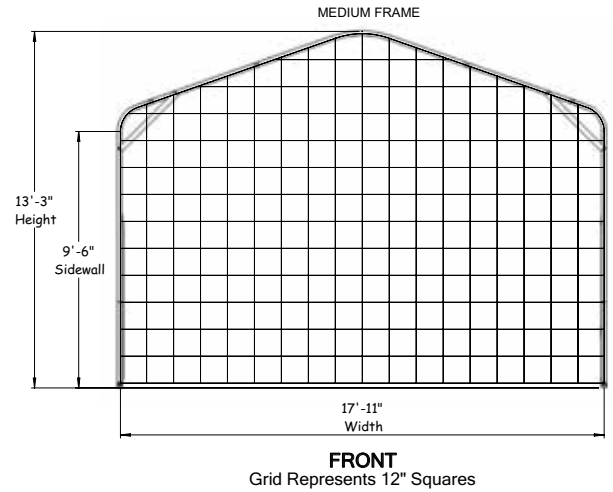
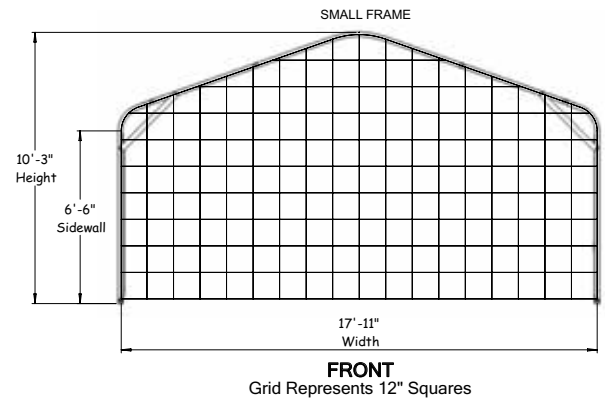

Frame shown is the "Frame Only" purchase.

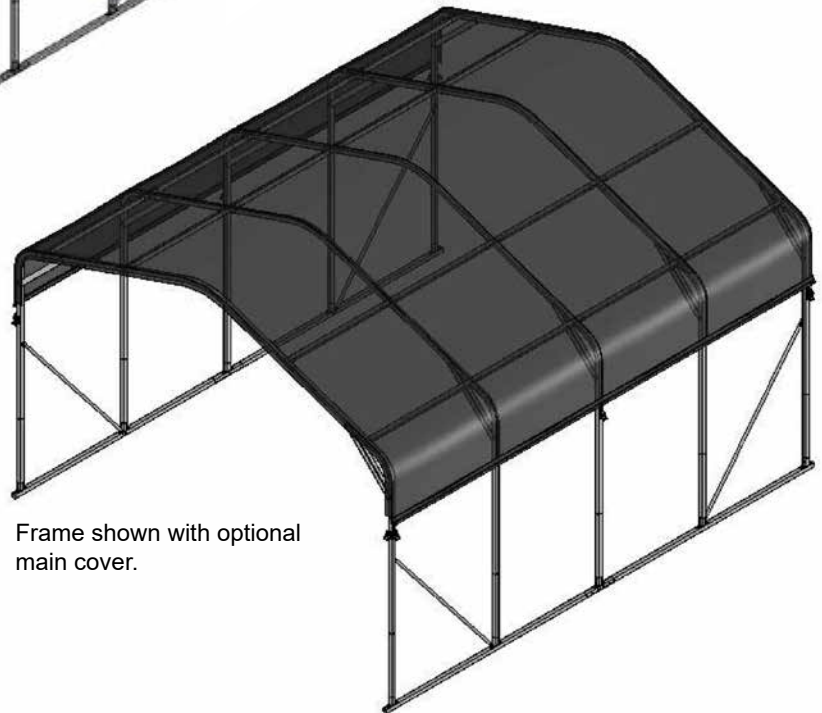

Frame shown with optional main cover.

Frames shown may differ in length and/or height from actual frame.

# FRONT PROFILE

**Connection Note**

Purlin connected to end rafters using 104626 tube fitting

Purlin connected to mid rafters using 104627 tube fitting

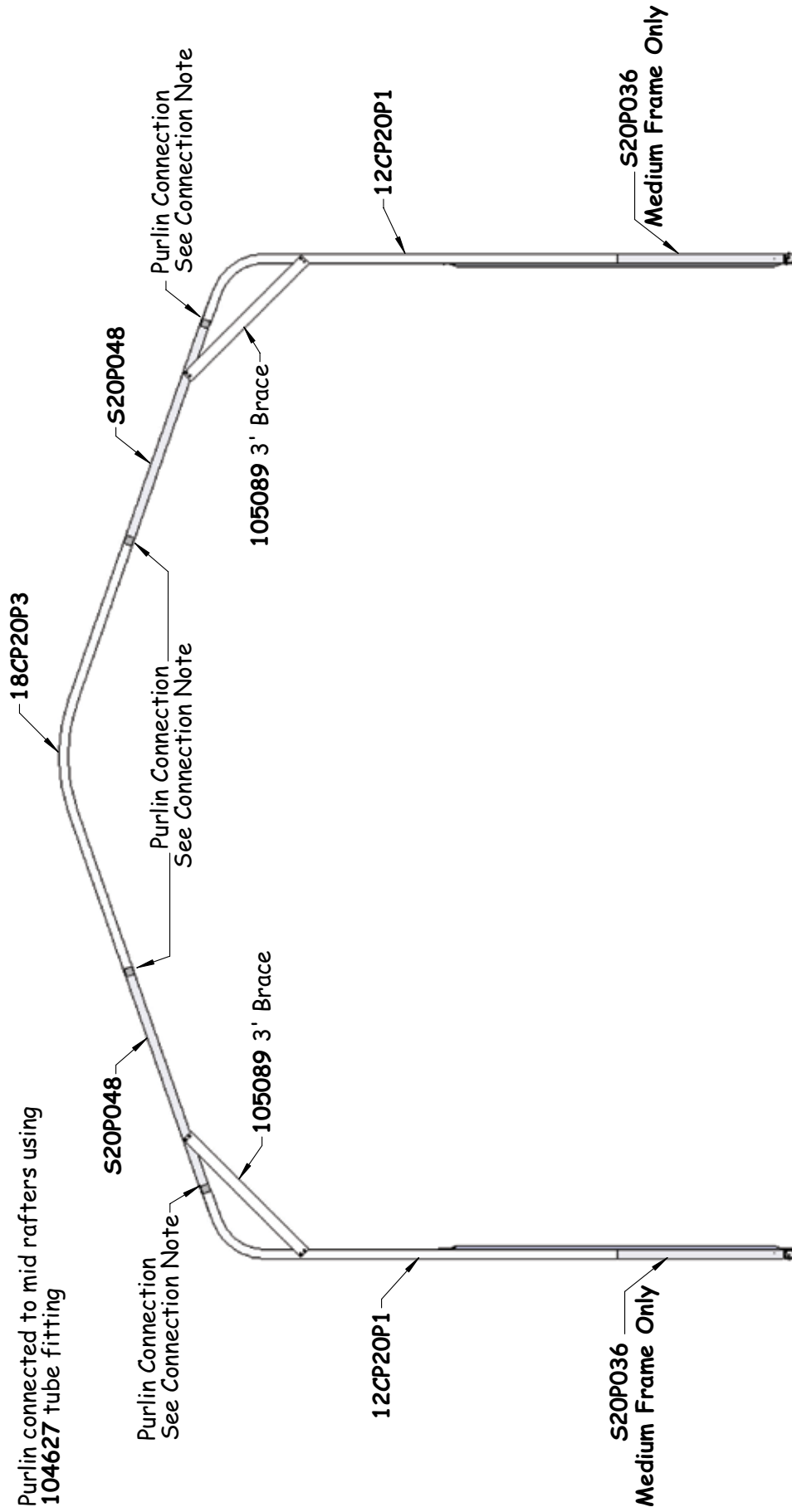

# SIDE PROFILE - 104968F

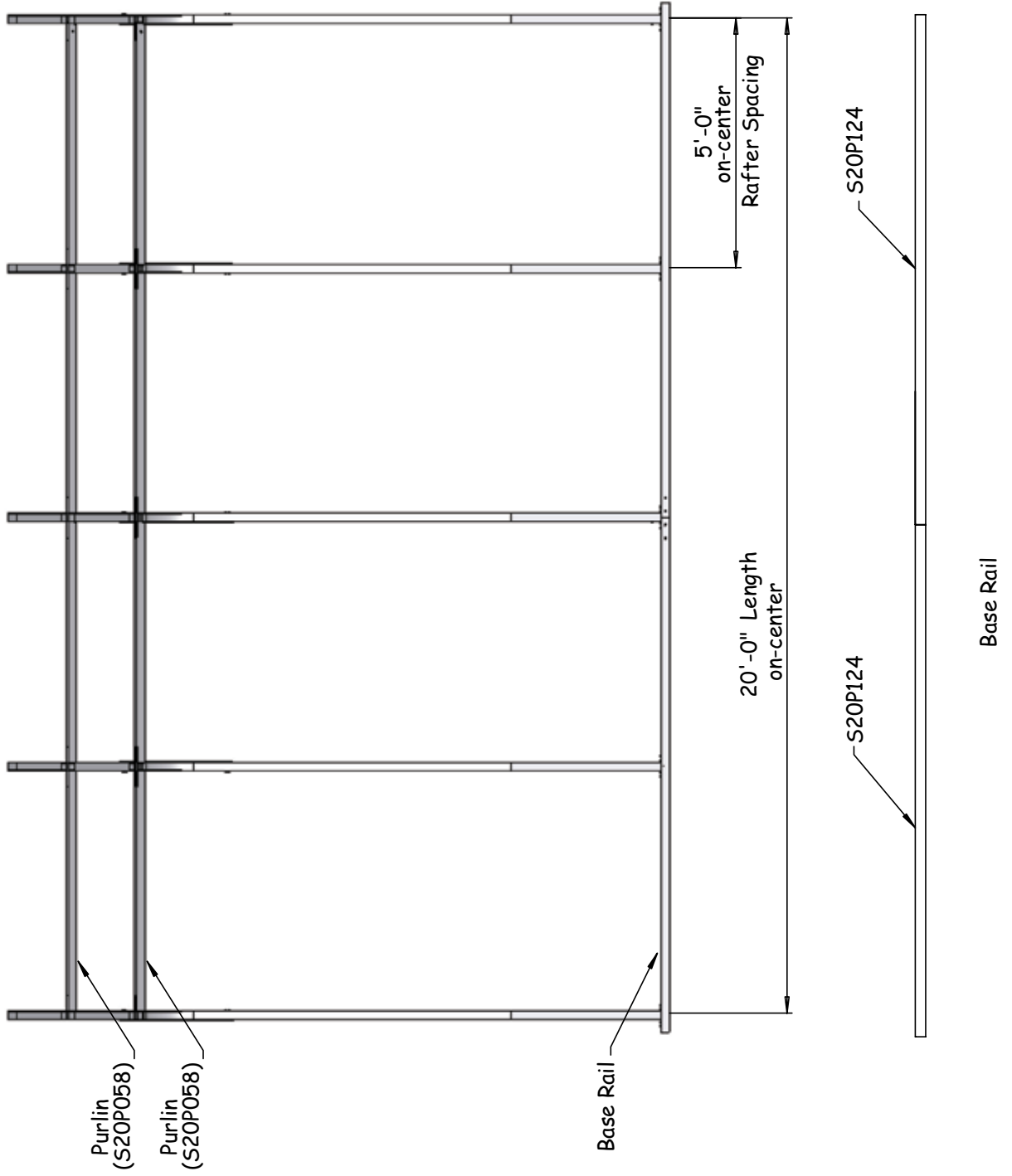

# SIDE PROFILE - 104969F

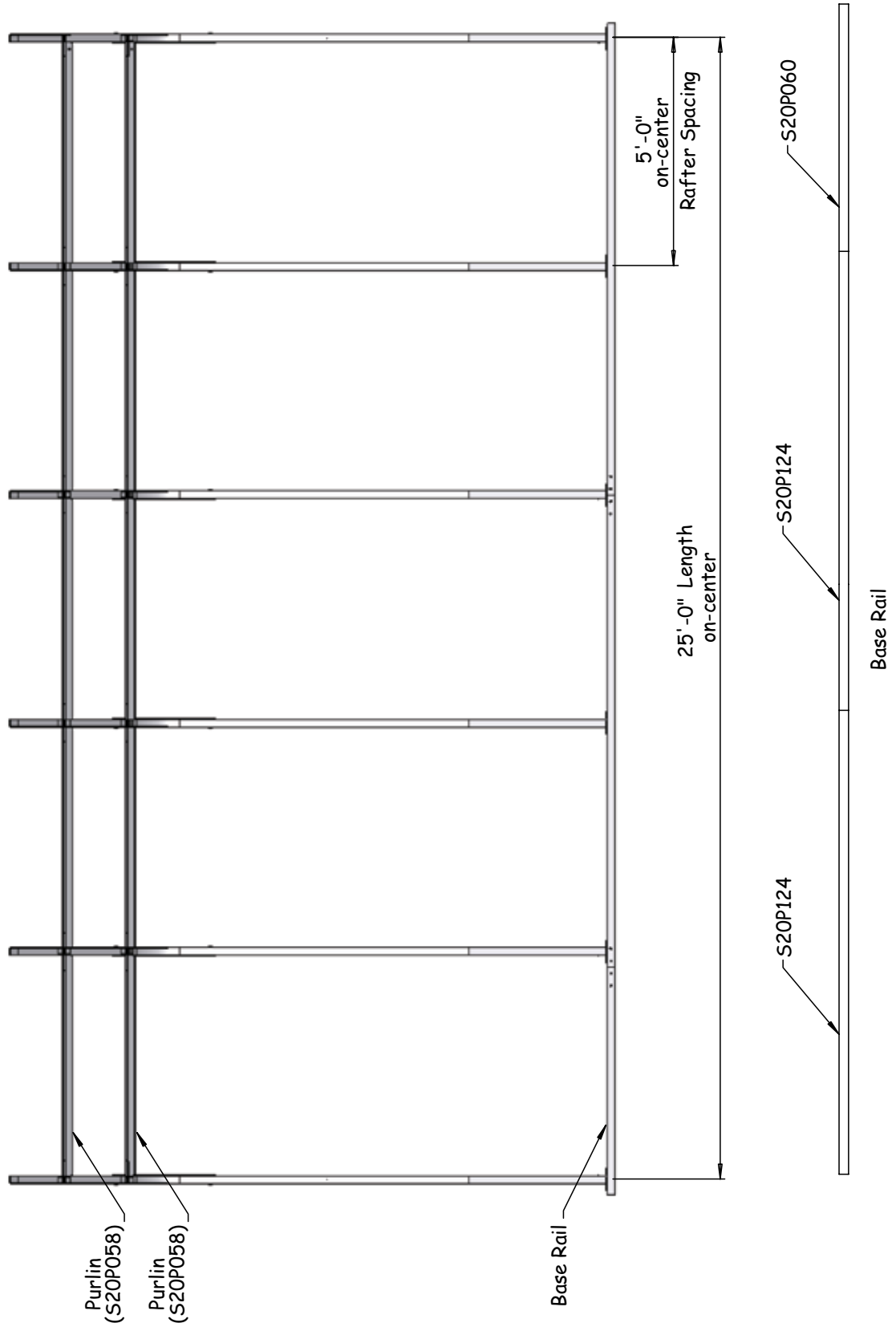

# SIDE PROFILE - 104970F

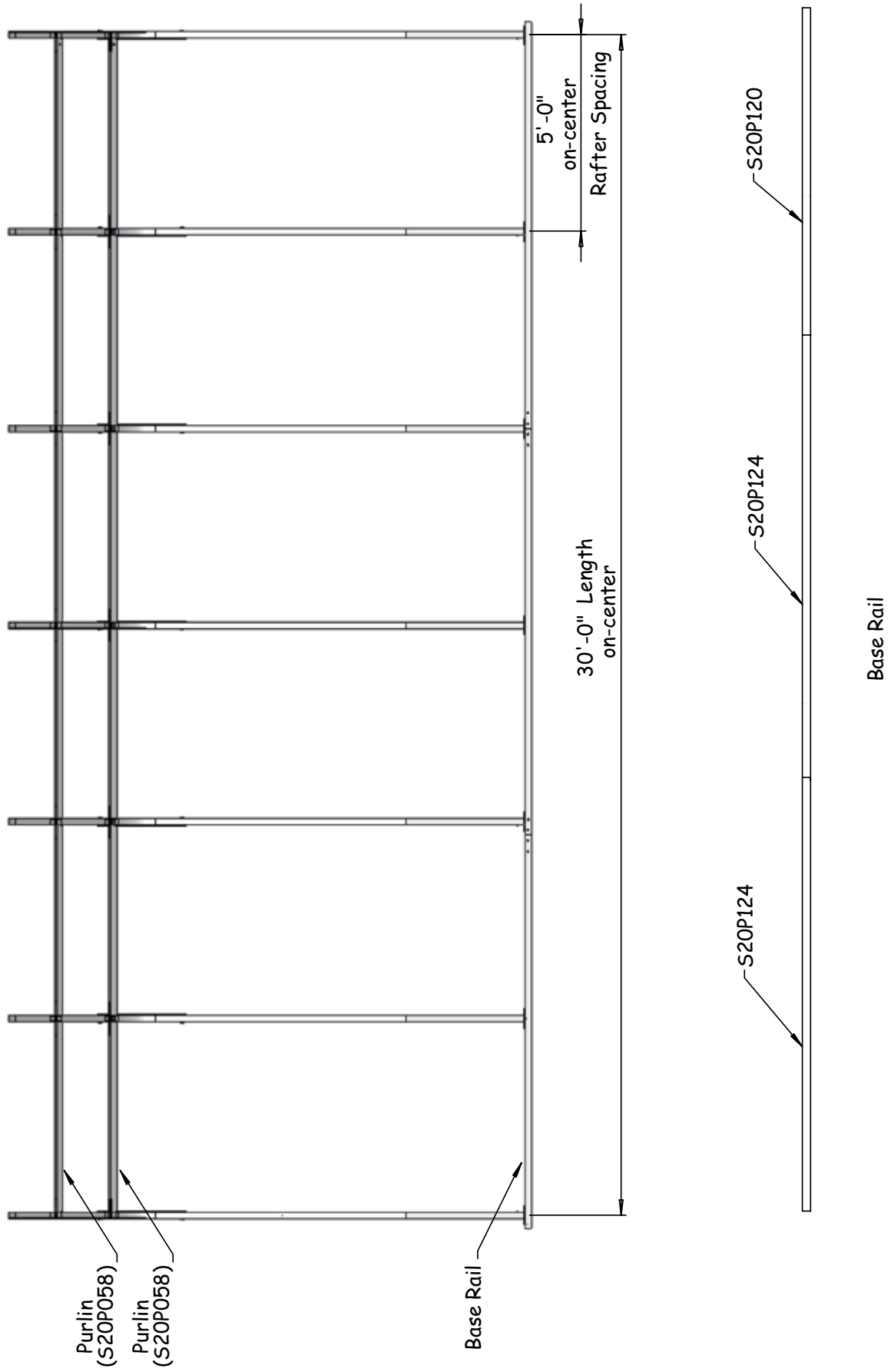



# SIDE PROFILE - 104971F

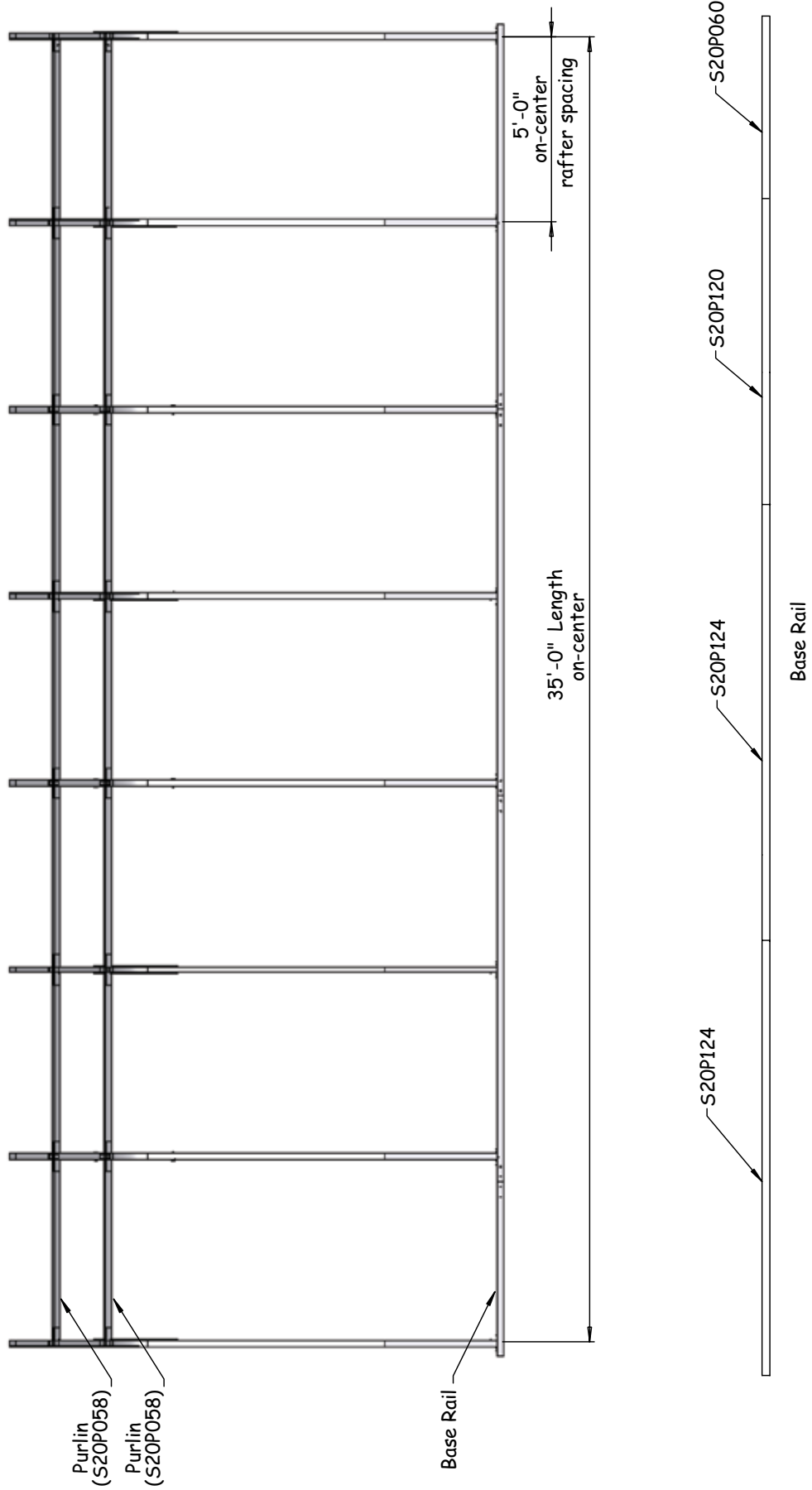

# SIDE PROFILE - 104972F

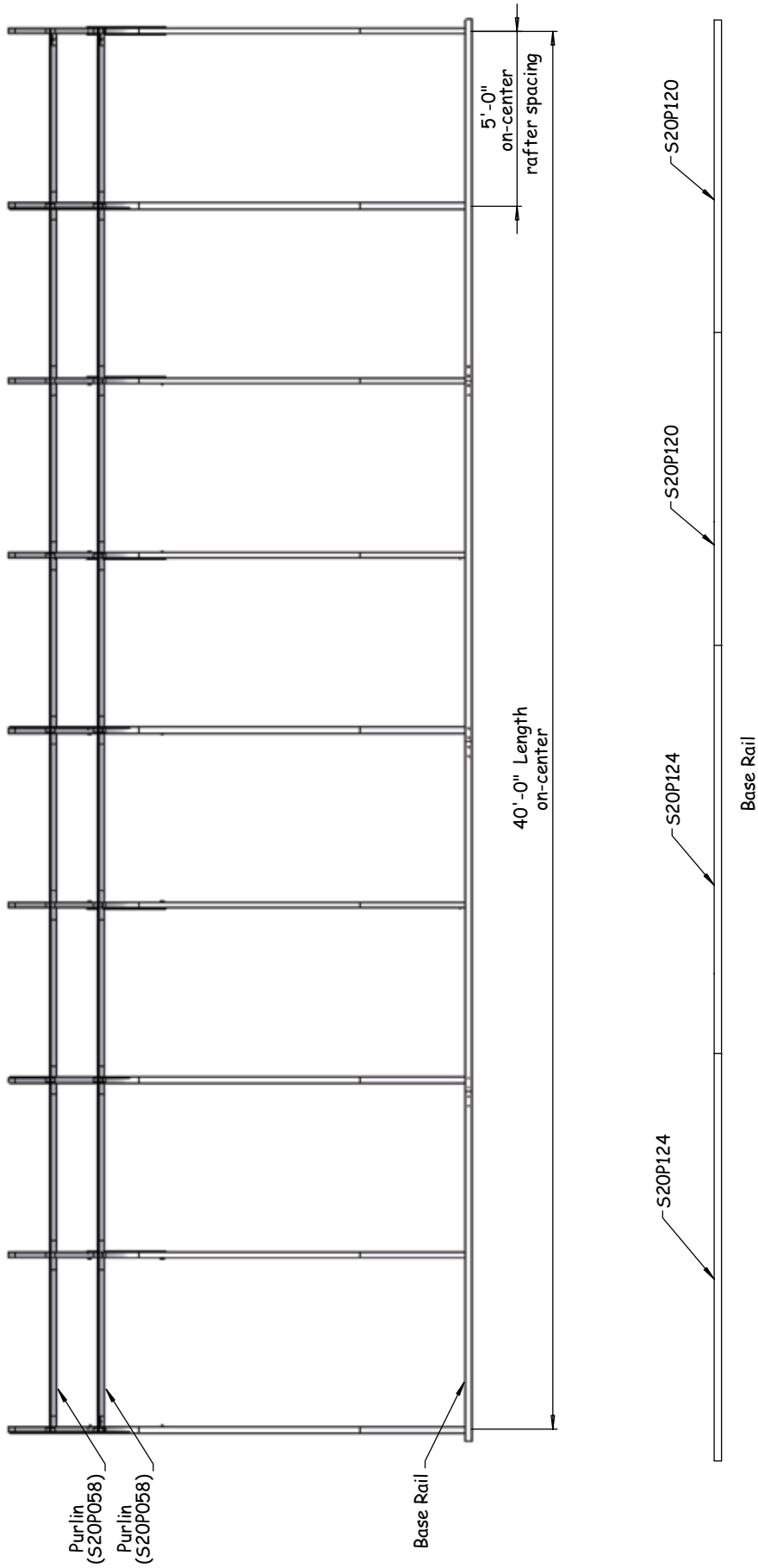

# SIDE PROFILE - 104973F

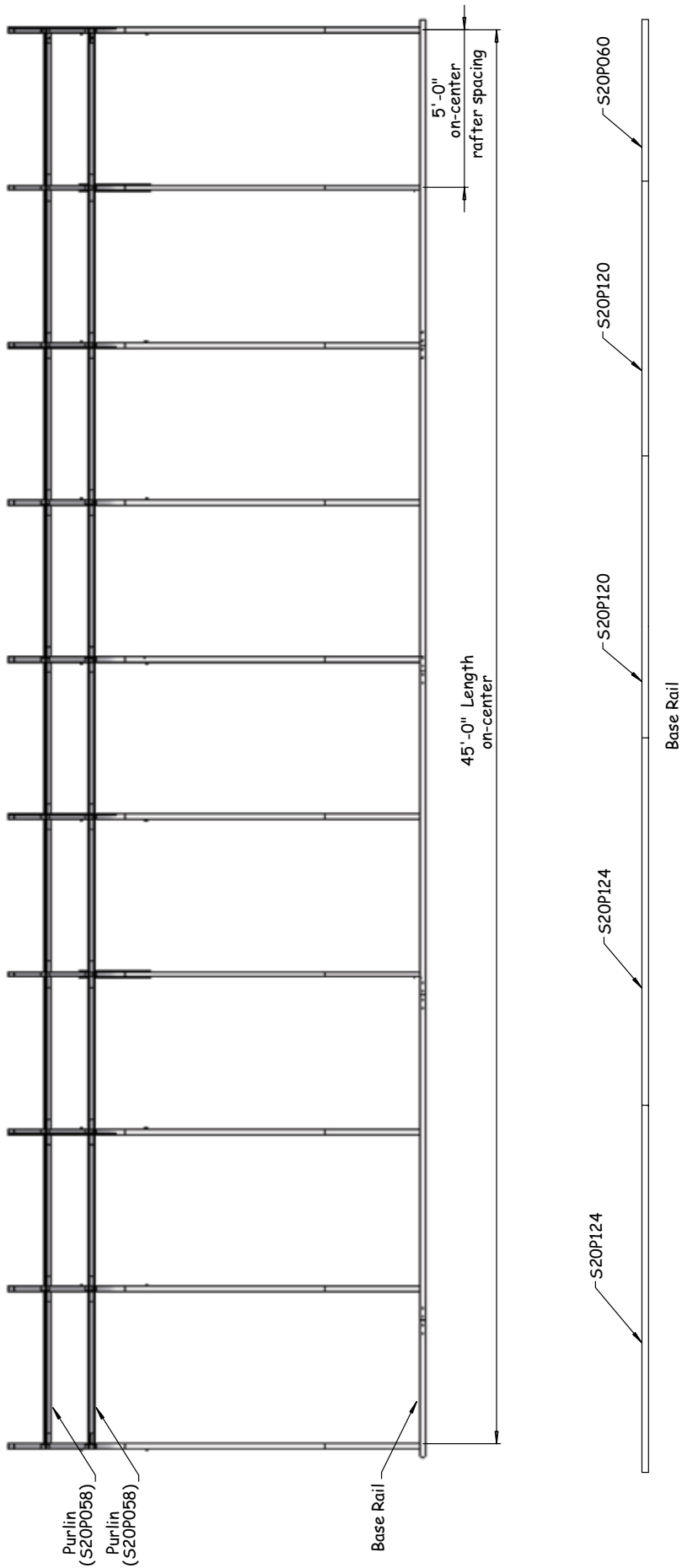

# CONNECTIONS

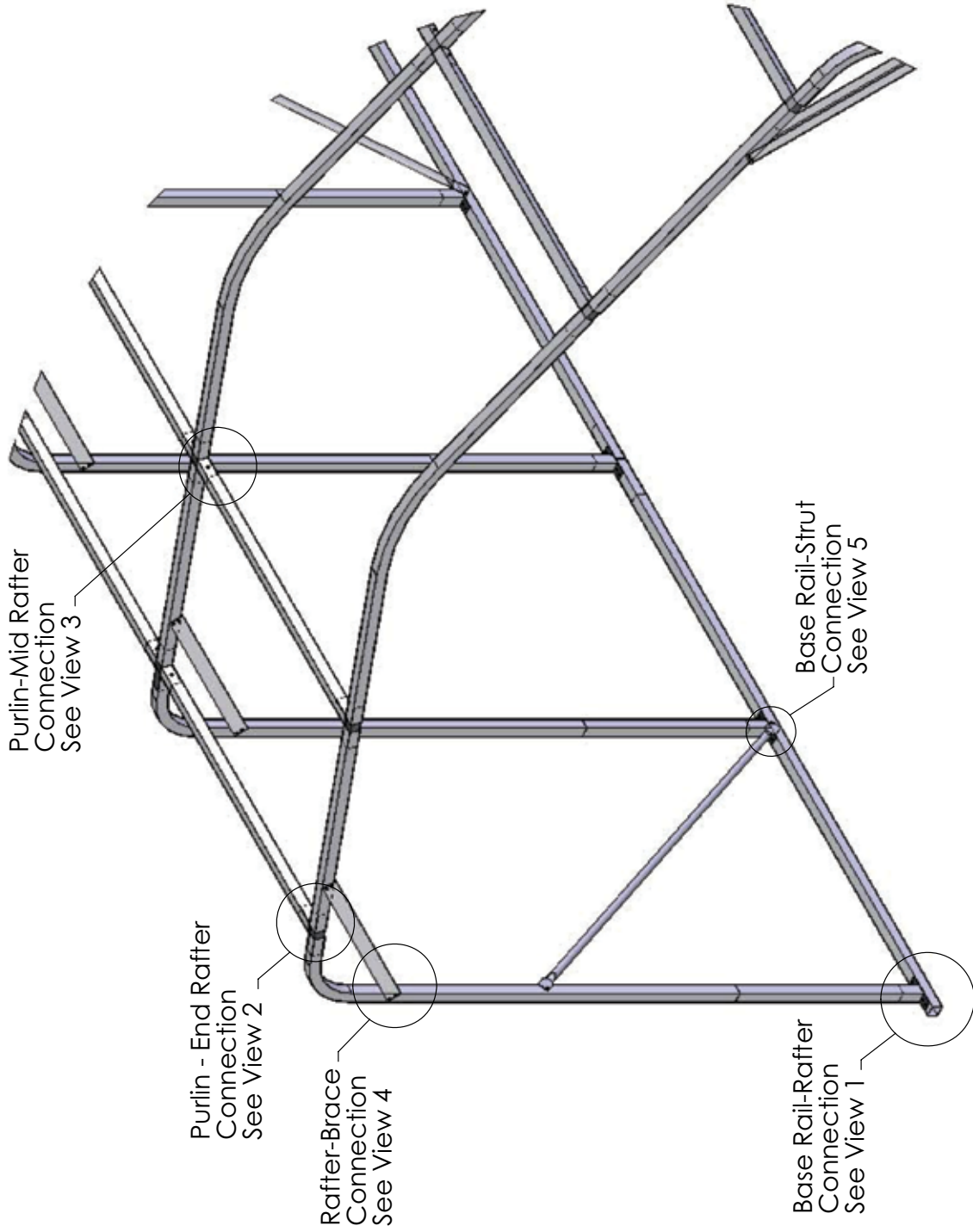

NOTE: Plain tubing connected using 104075

# CONNECTION - DETAILS

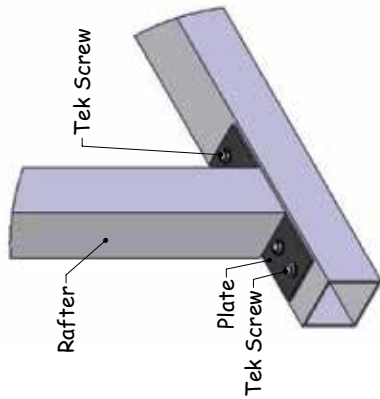

**VIEW 1**  
**BASE RAIL-RAFTER**

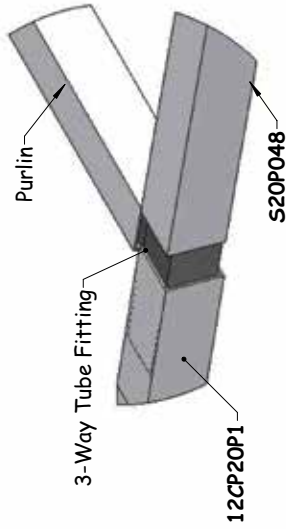

**VIEW 2**  
**PURLIN-END RAFTER**

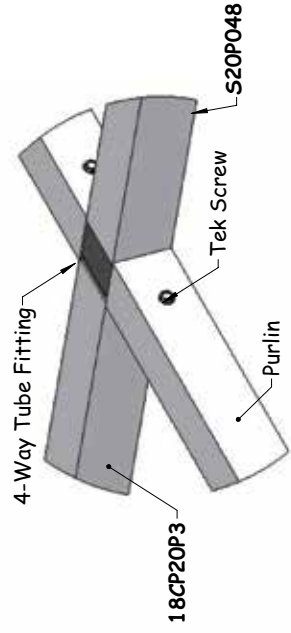

**VIEW 3**  
**PURLIN-MID RAFTER**

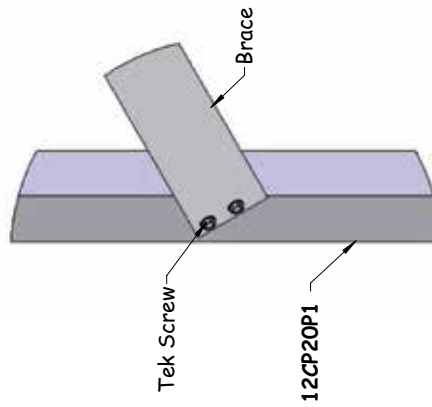

**VIEW 4**  
**RAFTER-BRACE**

NOTE: Brace attaches in similar fashion at other end

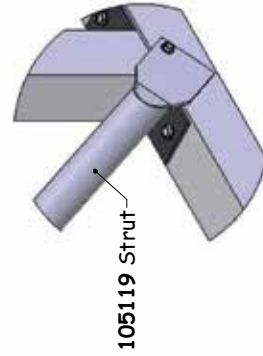

**VIEW 5**  
**BASE RAIL-STRUT**

NOTE: Strut attaches in similar fashion to rafter