



**GrowSpan™**  
**Gothic Pro Greenhouses and Systems**



*Photo may show a different but similar model.*

STK#	DIMENSIONS
104840	14' W x 9' 6" H x 16' L
104841	14' W x 9' 6" H x 20' L
104842	14' W x 9' 6" H x 24' L
104843	14' W x 9' 6" H x 28' L



## YOU MUST READ THIS DOCUMENT BEFORE YOU BEGIN TO ASSEMBLE THE SHELTER.

Thank you for purchasing this GrowSpan™ greenhouse. When properly assembled and maintained, this product will provide years of reliable service. These instructions include helpful hints and important information needed to safely assemble and properly maintain the greenhouse. Please read these instructions **before** you begin.

If you have any questions during the assembly, contact Customer Service at 1-800-245-9881 for assistance.

## SAFETY PRECAUTIONS

- Wear eye protection.
- Wear head protection.
- Wear gloves when handling metal tubes.
- Use a portable GFCI (Ground Fault Circuit Interrupter) when working with power tools and cords.
- Do not climb on the greenhouse or framing during or after construction.
- Do not occupy the greenhouse during high winds, tornadoes, or hurricanes.
- Provide adequate ventilation if the structure is enclosed.
- Do not store hazardous materials in the greenhouse.
- Provide proper ingress and egress to prevent entrapment.

## ANCHORING INSTRUCTIONS

Prior to assembling this greenhouse, please read the **MUST READ** document included with the shipment.

**⚠ WARNING:** The anchor assembly is an integral part of the greenhouse construction. Improper anchoring may cause greenhouse instability and failure of the structure. Failing to anchor the greenhouse properly *will void the manufacturer's warranty* and may cause serious injury and damage.

## LOCATION

Choosing the proper location is an important step before you begin to assemble the structure.

The following suggestions and precautions will help you determine whether your selected location is the best location.

- Never erect the structure under power lines.
- Identify whether underground cables and pipes are present *before* preparing the site or anchoring the structure.
- Location should be away from structures that could cause snow to drift on or around the building.
- Do not position the greenhouse where large loads such as snow and ice, large tree branches, or other overhead obstacles could fall.
- *Always check local building codes before you begin.*

## SITE

After choosing a location, proper preparation of the site is essential. The following site characteristics will help ensure the integrity of the structure.

- *A level site is required.* The site must be level to properly and safely erect and anchor the structure.
- If the site is not level, use footings to provide a secure base to assemble the structure. Pre-cast concrete blocks, pressure-treated wood posts, or poured footings are all acceptable when properly used. (Some shelters use ground posts or rafter feet.)
- **Drainage:** Water draining off the structure and from areas surrounding the site should drain away from the site to prevent damage to the site, the structure, and contents of the structure.

**⚠ WARNING:** The individuals assembling this structure are responsible for designing and furnishing all temporary bracing, shoring and support needed during the assembly process. For safety reasons, those who are not familiar with recognized construction methods and techniques *must seek the help of a qualified contractor.*

## DOUBLE-LAYER FILM INSTALLATION

Greenhouses equipped with a double-layer film include a layer that is Infra Red (IR) Retention film.

**IMPORTANT! During cover installation, the IR film must be installed first! Examine the film and install it according to the instructions printed on the film.**

## ASSEMBLY PROCEDURE

Following the instructions as presented will help ensure the proper assembly of your greenhouse. Failing to follow these steps may result in an improperly assembled and anchored greenhouse and will void all warranty and protection the owner is entitled.

The steps outlining the assembly process are as follows:

1. Verify that all parts are included in the shipment. Notify Customer Service for questions or concerns.
2. Read these instructions, the Must Read document, and all additional documentation included with the shipment **before** you begin assembling the greenhouse.
3. Gather the tools, bracing, ladders (and lifts), and assistance needed to assemble the greenhouse.
4. Check the weather **before** you install the roof cover and any panels (if equipped). Do not install covers or panels on a windy or stormy day.
5. Re-evaluate the location and site based on the information and precautions presented in the documentation included with the shipment.
6. Prepare the site (if applicable).
7. Assemble the frame components in the order they are presented in these instructions.
8. Assemble the frame including the struts (if equipped).
9. Consult the MUST READ document and properly anchor the assembled frame.
10. Install the End Wall framing.
11. Install, tighten, and secure the End Wall end panels and doors.
12. Install, tighten, and secure the main cover. This applies to fabric and film covers that stretch over the frame assembly.
13. Read the Care and Maintenance information at the end of these instructions.

## LIST OF WORDS AND PHRASES

Before you begin, it is important to become familiar with the words and phrases used in this instruction manual.

These words and phrases are common to most GrowSpan™ shelters and identify the different parts of the shelter. (Some are used in this document. Others may not apply to this particular shelter.) These terms describe the shipped parts and can also be found on the materials list/spec sheets included with the shipment. To aid in the assembly, read through the following definitions before you begin to assemble your shelter.

- **Band Clamp:** Clamp used to connect the end wall framing to the rafter pipe. In some cases, band clamps are also used to connect diagonal struts to the assembled frame.
- **Clip or Fabric Clip:** A short, half-section piece of conduit (cut lengthwise) used to secure the end panel cover to the leg or rafter assembly. The clip or fabric clip is typically fastened in place using self tapping Tek screw.
- **Conduit:** An assembly of pipes used to secure the main cover and end panels (if equipped). Purlins and some strut assemblies also consist of connected pipes to form a conduit. Each pipe joint of a conduit assembly is secured with a self-tapping Tek screw to prevent separation. Some conduit assemblies are used to secure larger end panels and main covers. These conduits typically consist of sections of PVC tubing glued at the joints.
- **Cross Connector:** Any one of the metal brackets used to "connect" or secure a purlin to a rafter. Cross-connectors are typically pictured on the Pictorial Parts Guide page or in the Quick Start section (if present).
- **End Panel:** Fabric or material used to cover the end wall assemblies. End wall assemblies are optional for many shelters.
- **Must Read Document:** This document includes building and shelter anchoring instructions, steps for end wall reinforcement, safety precautions, and notices and warnings. The Must Read document is sent with all shelters and buildings. If you did not receive a Must Read document, contact Customer Service to request one.
- **On-Center:** Term used to describe a measurement taken from the vertical center of the rafter or frame member to the vertical center of another.
- **Purlin:** The pipe assembly that runs perpendicular to the rafters or framework that supports the main cover. Purlins are found on the sides and roof areas of the assembled frame, are evenly spaced, and typically run from the front to the back of the shelter.
- **Plain or Straight Pipe:** A term used to describe a pipe that has the same diameter or width throughout its entire length.
- **Strut:** A strut is usually a length of pipe with two flattened ends and is used for diagonal bracing of the shelter frame. A strut is typically secured to the frame work by special brackets and bolts.
- **Swaged End or Swaged Pipe:** The term "swaged" refers to the tapered end of the pipe or tube. Swaged ends of a pipe can be inserted into couplers and the straight ends of other pipes.
- **Tek Screw:** A self-tapping fastener used to secure pipe joints and to fasten brackets to rafters.

## GROWSPAN™ GOTHIC PRO GREENHOUSES AND SYSTEMS

### REQUIRED TOOLS

The following list identifies the main tools needed to assemble the shelter. Additional tools and supports may be needed depending on the structure, location, and application.

- Tape measure or measuring device
- Marker to mark locations on the pipes
- Variable speed drill and impact driver (cordless with extra batteries works best)
- Metal-cutting saw
- Wrenches and impact socket set, or an adjustable wrench
- Scissors, utility knife, or tin snips
- Hammers and gloves
- Adjustable pliers and self-locking pliers
- Ladders, work platforms, and other machinery for lifting designed to work safely at the height of the building
- Rope/cable for cover installation

### UNPACK AND IDENTIFY PARTS

The following steps will ensure that you have all the necessary parts *before* you begin to assemble the shelter frame.

1. Unpack the contents of the shipment and place where you can easily inventory the parts. Refer to the Bill of Materials/Spec Sheets.
2. Verify that all parts listed on the Bill of Materials/Spec Sheets are present. If anything is missing or you have questions, consult the Pictorial Parts Guide and all diagrams for clarification, or contact Customer Service.

**NOTE:** At this time, you do not need to open the plastic bags containing smaller parts such as fasteners or washers (if equipped).

### QUICK START GUIDE

For a quick overview of this shelter and its components, consult the Quick Start Guide near the back of these instructions.

The pages of the Quick Start Guide show exploded views of all critical connections. Use the diagrams in the Quick Start section to assemble the frame of your building.

Consult the remainder of these instructions for important details that will help during the construction.

### SPECIAL NOTE: Baseboards for Frame

These instructions describe installing a baseboard (recommended) at ground level along each side of the frame. The baseboard runs from the front to the back of the frame.

This baseboard is *not included* with the shipment and must be supplied by the customer. Treated or recycled plastic lumber works well for a baseboard.

The baseboard, when installed properly, helps prevent ground posts from sinking when anchored. Depending on building, it also provides a surface to attach struts or other building components. **Secure baseboard using the supplied FAH009B (1/4" x 4") bolts and FALB01B (1/4") nuts.**

Consult these instructions, or contact Customer Service for additional information regarding baseboards.

### ANTI-BILLOW ROPE INSTALLATION

TO PREVENT DAMAGE AND POSSIBLE INJURY, INSTALL THE ANTI-BILLOW ROPES IN SHORT LENGTHS ALONG EACH SIDE OF THE FRAME.

DO NOT INSTALL AS A SINGLE LENGTH TIED AT EACH END OF THE BUILDING. DOING SO WILL RESULT IN A LOOSE SIDE PANEL IF THE SINGLE ROPE BREAKS DURING STRONG WINDS.

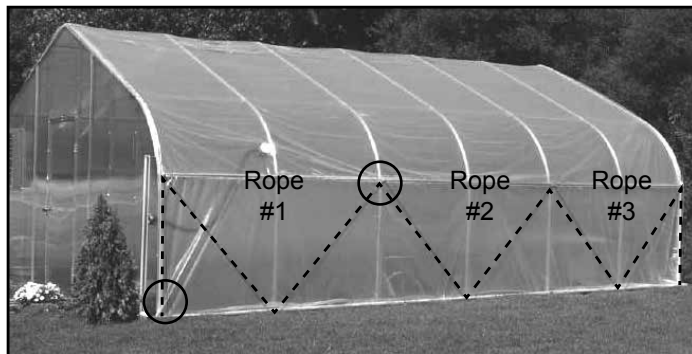

Dotted line represents the anti-billow rope.  
Example: Circles identify the ends of Rope #1.

### IMPORTANT: POLYCARBONATE PANELS

Do not allow polycarbonate panels to remain in direct sunlight prior to installation. Doing so will cause the protective film to become difficult if not impossible to remove.

Prior to installation, cover panels using a light colored tarp to reflect sunlight or store indoors or in the shade.



The following graphics and photos will help you identify the different parts and show you how they are used. (Some parts are not shown.)

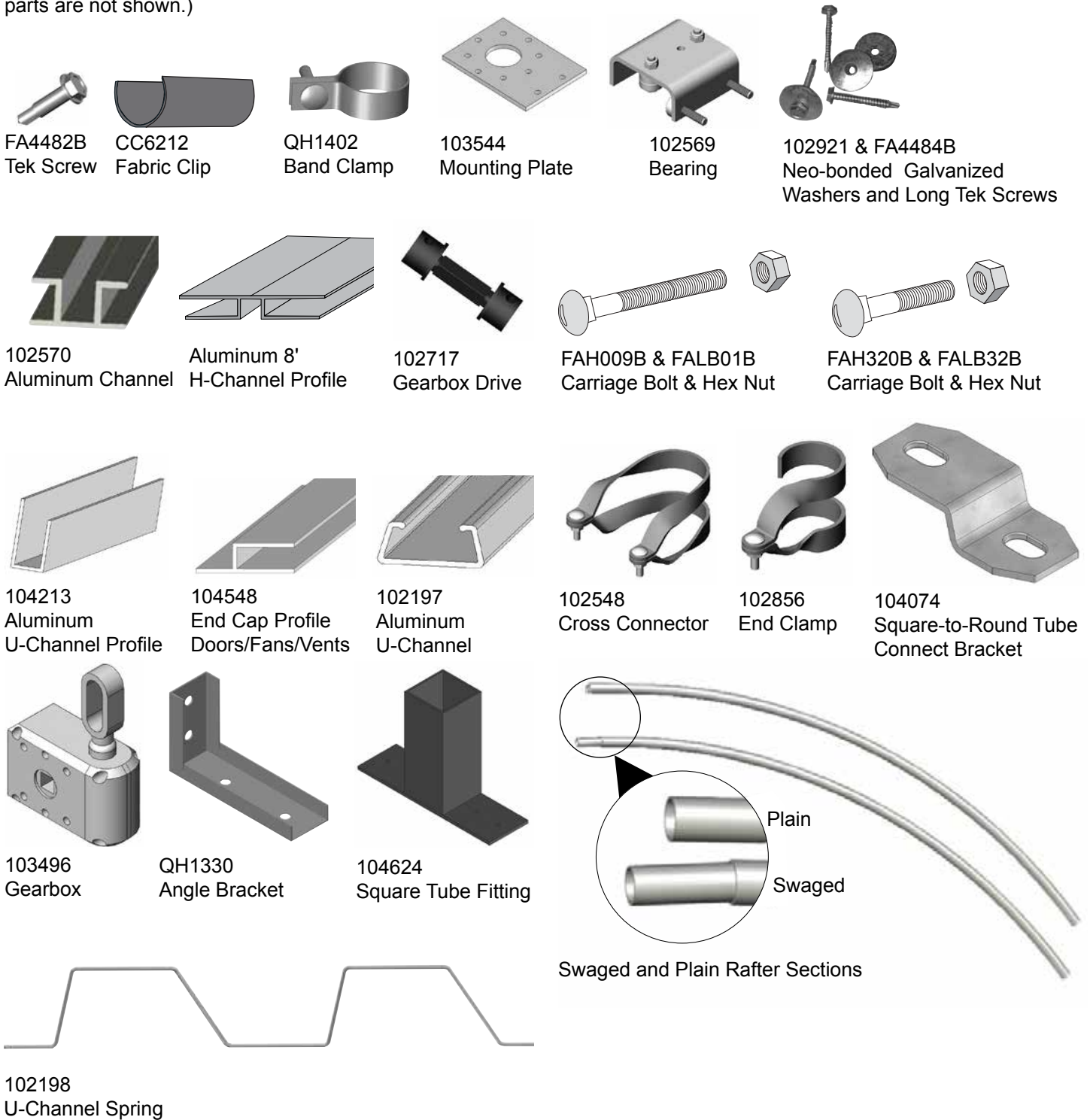

## H-CHANNEL INSTALLATION INSTRUCTIONS

The new H-channel design requires installation of the flat side facing out with channel side toward the building. Some diagrams and photos in this document show installation of *original* H-channel with channel side facing out. Design of new H-channel *does not allow* channel-side out installation.

Use the diagrams on this page to install H-channel with flat side facing out.



**ATTENTION:** Use only 1-1/2" Tek screws to attach H-channel to building frame. **Do not use shorter screws. They will not hold. Do not use washers on Tek screws when installing H-channel.**

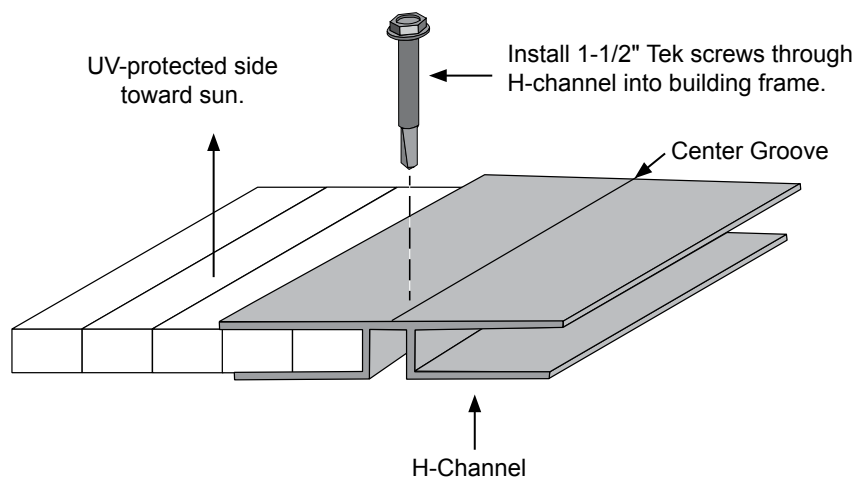
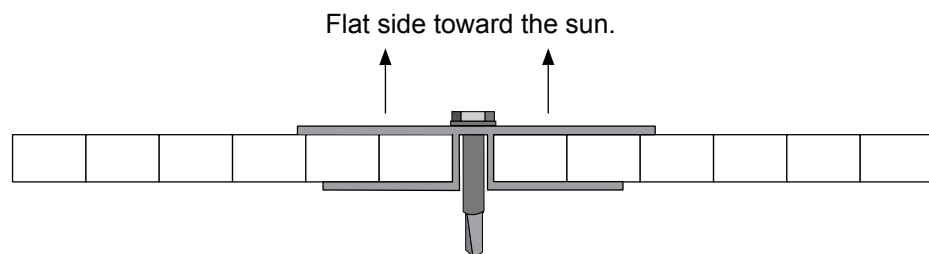
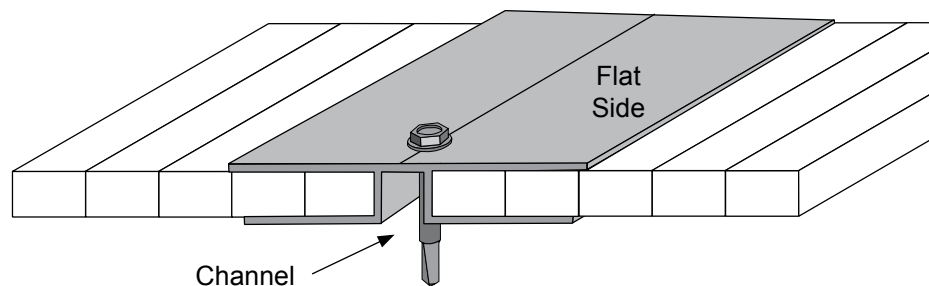

**ATTENTION:** Install all twin-wall poly carbonate panels with UV-protected side toward the sun.



## GrowSpan™ Gothic Pro Greenhouses and Systems

### OVERVIEW

This section describes assembling your greenhouse. For details, please see section, Assembling the Gothic Pro Greenhouse Components. See illustration below to identify main parts of greenhouse.

1. Locate the required parts for each assembly procedure.
2. Assemble the rafters and frame, and square the frame.
3. Prepare and attach end panels.
4. Attach main cover and Twist-of-the-Wrist assembly.

**ATTENTION:** Position purlins evenly during the frame assembly. Use the rafter pipe joints as guides when installing the end clamps, cross connectors, and purlins.

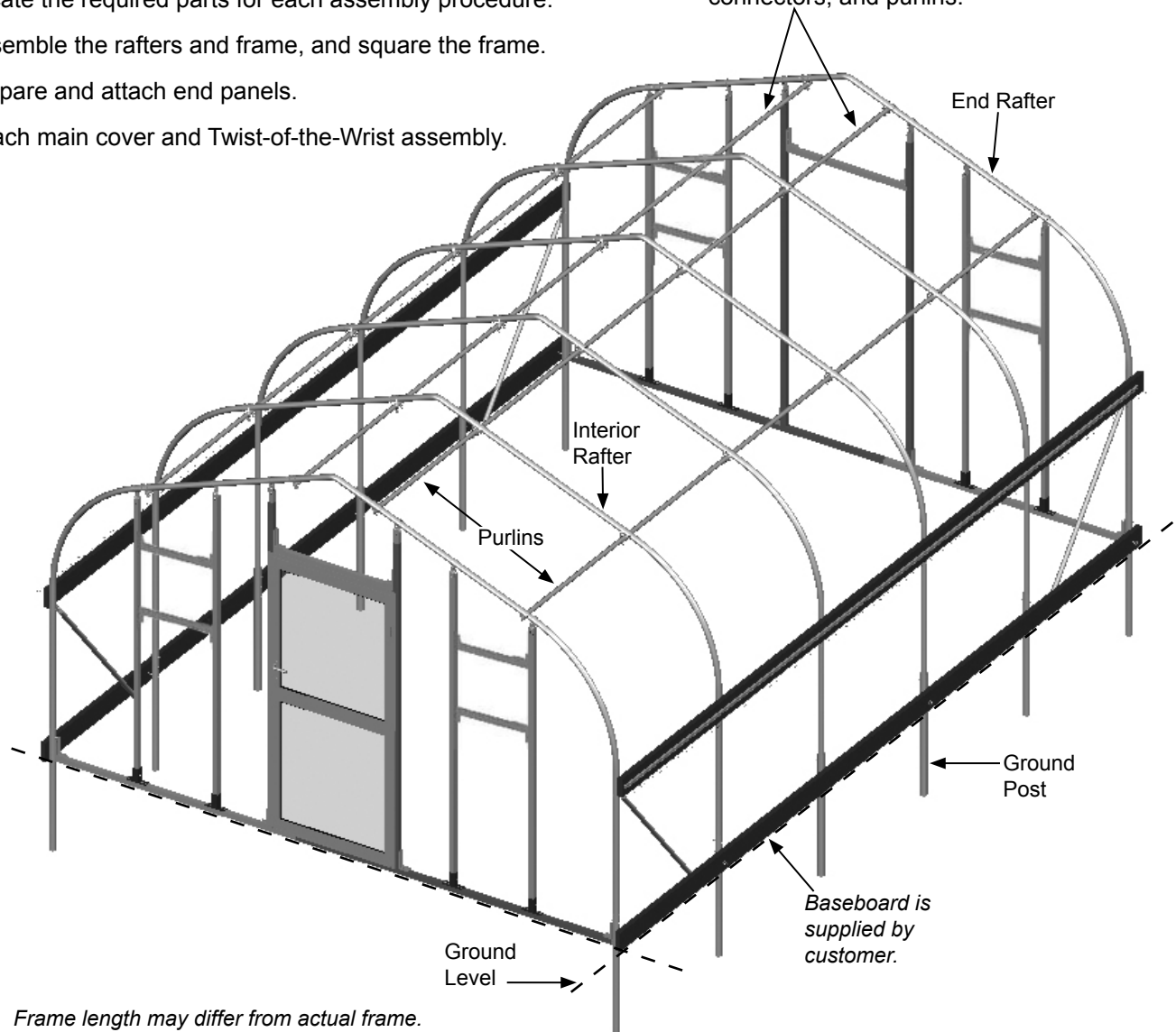

*Frame length may differ from actual frame.*

## GROWSPAN™ GOTHIC PRO GREENHOUSES AND SYSTEMS

### LAY OUT THE BUILDING SITE

After the site is prepared, lay out the building site.

Taking these steps *before* assembling the shelter saves time and ensures that the structure is positioned as desired.

*Ground posts must be driven to the proper depth. Width of the shelter is measured from the center of one ground post to the center of the remaining ground post.*

### SQUARE THE SITE

Gather the Parts:

- Ground Posts
- 5/16" x 2-1/2" Machine Bolts
- 5/16" Nuts

1. Identify a corner where a ground post will be positioned and drive the first ground post into the ground.

**NOTE:** Insert the ground post driver into the top of the ground post to protect the post and drive the post into the ground. *The top of the post will be one (1) foot above the finished grade when properly driven.*

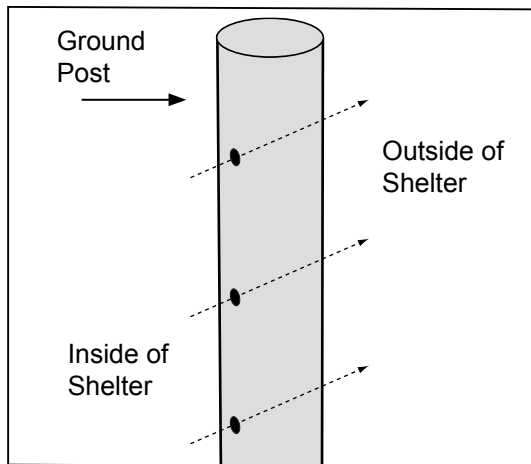

**ATTENTION:** Position the pre-drilled holes facing to the inside/outside of the shelter so they can be aligned with the bolt holes in the rafter legs.

To align the bolt holes in the ground posts with those in the rafter *after driving the ground posts*, insert a tapered rod or pry bar into a ground post bolt hole and turn the post using the rod or pry bar.

2. After the first corner ground post is in place, string a line the width of the building (center-to-center) and drive the second ground post into the ground just enough to hold it in place.

3. Use a transit or line level to drive the second corner post to the same depth as the first ground post.
4. String a line at least as long as the building from the first stake at 90°.

**NOTE:** A transit can be used to ensure an accurate 90° angle, or the 3-4-5 rule can be used. Refer to diagram. Using multiples of 3-4-5 such as 6-8-10 or 12-16-20 helps to maintain an accurate 90° angle.

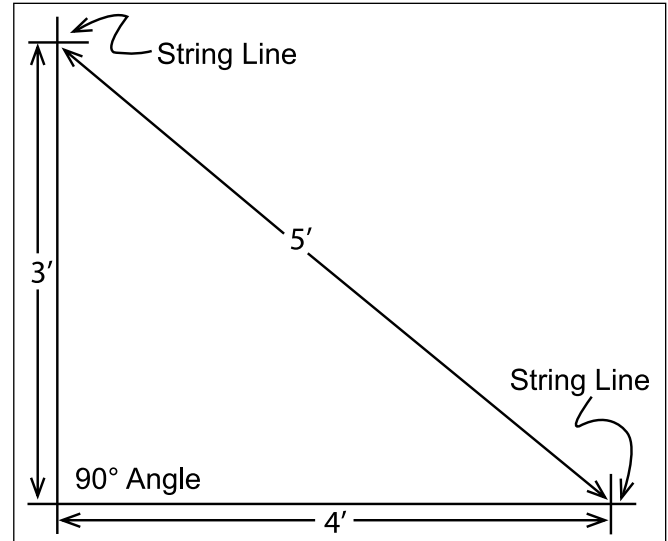

5. After squaring the position of the building, measure the length (center-to-center) and drive the next corner ground post.
6. Repeat the same step for the last corner post.

**NOTE:** The distance measured diagonally between corner posts must be equal for the building to be square.

7. Check all dimensions (and adjust if needed) before driving the remaining posts to the required height.
8. After all corner posts are accurately installed, tie a string line between the tops of the corner ground posts on the same side of the shelter. The string is used to identify the tops of all remaining ground posts. The string must remain tight and level.
9. Use a tape measure to mark the 48" on-center locations of the remaining ground posts.
10. Drive the remaining ground posts into the ground at the required 48" on-center width and the height identified by the string.

**NOTE:** Verify that the holes in the ground posts are in the proper position and that each post is plumb and driven to the correct depth.

11. Continue with the **Rafter Assembly** steps that follow.

**ASSEMBLING THE GOTHIC PRO GREENHOUSE FRAME COMPONENTS**

After the site is prepared and an inventory of parts is complete, continue with the rafter assembly.

**NOTE:** All rafter assemblies consist of rafter tubes and purlin clamps. Consult the rafter diagram in the Quick Start section of these instructions before and during the rafter assembly process.

Assistance is required to assemble the greenhouse frame.

**RAFTER ASSEMBLY**

Gather the Parts:

- Rafter Pipe (#18G16A)
- Rafter Pipe (#18G16B)
- Rafter Pipe (#166S051)
- End Clamps (#102856)
- Tek Screws (#FA4482B)
- Magnetic nut setter (3/8" x 2-9/16")

**END RAFTER ASSEMBLY**

The end rafters include purlin end clamps and band clamps. Install the purlin end clamps before the different pipes of the rafters are connected. The band clamps for the side struts are installed when the two (2) end rafters are set onto the ground posts.

1. Select the five (5) pipes needed to assemble the first end rafter and arrange on a level surface.

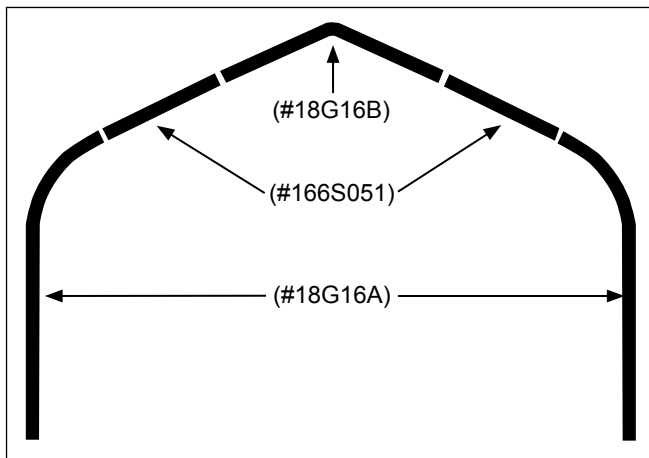

2. Slide four (4) end purlin clamps (two on each side of the peak) over the rafter pipes. Position all end clamps at the rafter pipe joints. Position the end clamps as shown.

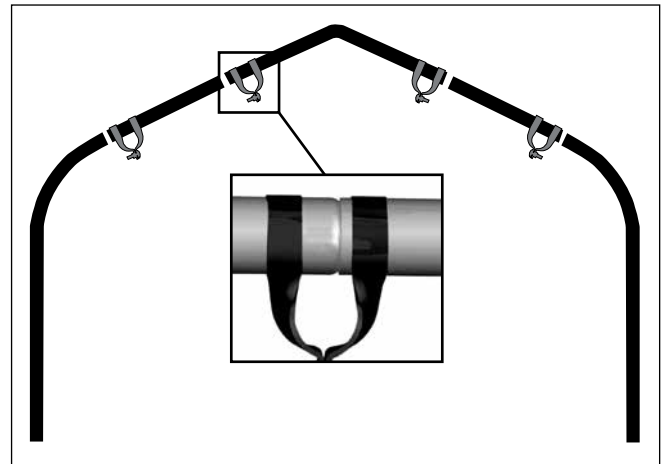

End clamp as seen from inside the assembled frame.

**NOTE:** Position all purlin clamps at the rafter pipe joints. Consult the Quick Start section for additional information.

3. After slipping the clamps over the rafter pipes, insert the swaged end of the rafter pipes into the plain ends of the pipes to assemble the rafter.
4. Once the rafter is assembled, reposition the purlin clamps over the pipe joints and install a Tek screw through the rafter pipes to secure each joint.

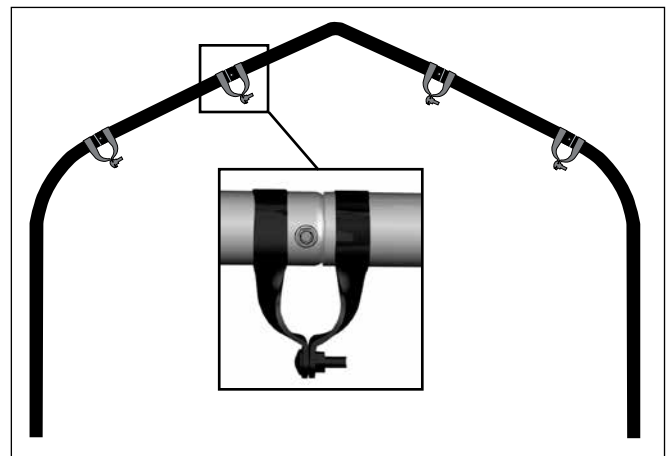

End clamp as seen from inside the assembled frame.

**IMPORTANT:** To prevent damage to the cover and end panels (if equipped), position the Tek screws so the heads do not contact the cover when it is installed.

5. Repeat steps for to assemble the remaining end rafter and set both end rafters aside.

## GROWSPAN™ GOTHIC PRO GREENHOUSES AND SYSTEMS

### RAFTER ASSEMBLY (continued)

#### INTERIOR RAFTER ASSEMBLY

Complete the following steps *for the interior rafters*.

1. Select the pipes for the first interior rafter assembly and position these on the ground as shown.

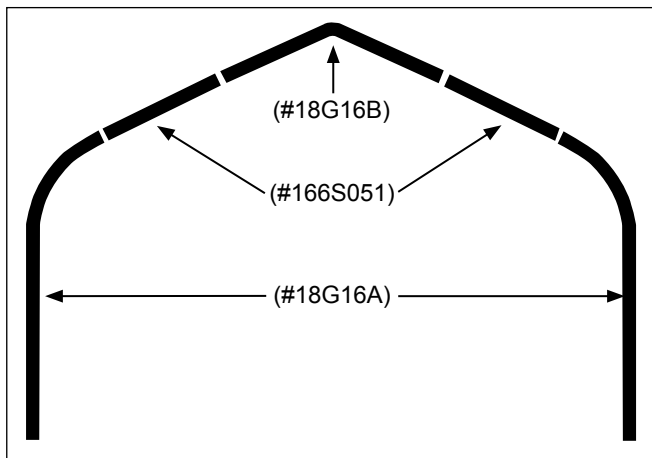

**IMPORTANT:** Interior rafters do not use end clamps. Instead, cross connectors are attached during the frame assembly.

2. Insert the swaged ends of the rafter pipes into the plain ends of the pipes and secure each joint with a Tek screw.

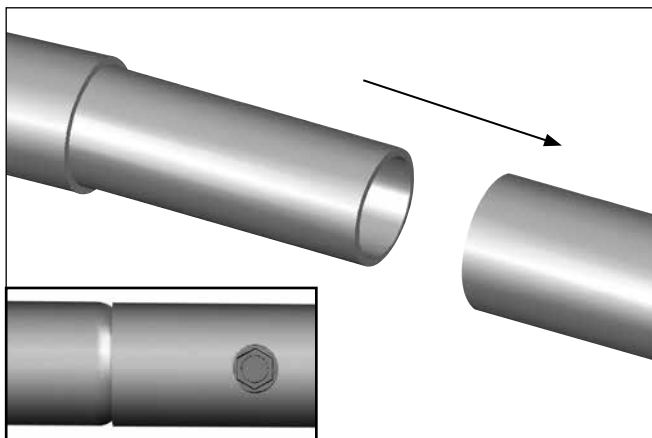

**NOTE:** For longer frames, it may be easier to assemble a few rafters at a time and then begin to assemble the frame. Position Tek screws so they will not contact the cover when the frame is assembled.

3. Once rafters are assembled, assemble the frame.

### FRAME ASSEMBLY

After all ground posts are driven in place and rafters are assembled, assemble the frame.

**NOTE:** The baseboards (strongly recommended) shown in the diagrams throughout these instructions are not included and must be supplied by the customer.

Contact Customer service at 1-800-245-9881 to purchase baseboards, or for additional information.

#### ASSEMBLE AND PRE-MARK THE PURLINS

The following steps describe one way to speed the assembly process and eliminate the need to measure each purlin as it is installed. Pre-marking the purlins ensures that an accurate spacing of the rafter assemblies is achieved and maintained during assembly.

Gather the Parts:

- Pipe 1.315" x 75" swaged (#131S075)
- Pipe 1.315" x XX" plain (#131P0XX)
- Marker and tape measure

**NOTE:** The purlins are part of the assembled frame and run perpendicular to the rafter assemblies. Each purlin consists of 1.315" x 75" (#131S075) swaged pipes (number is determined by shelter length) and one (1) 1.315" x XX" (#131P0XX) plain pipe.

**ATTENTION:** The XX" represents the remaining length required to reach the end of the shelter. Consult the Spec Sheet for part identification.

1. Select the required pipe sections for one purlin and connect these by inserting the swaged ends of the pipes into the plain ends until the entire purlin is assembled.

**NOTE:** Assemble the purlins in a location that is accessible during the assembly of the frame, but will not interfere with the process of lifting and setting the rafters.

2. Verify that each pipe joint is properly seated.

**NOTE:** These pipes must be separated during the assembly procedure. Do not fasten them together at this time.

3. For the 48" rafter spacing, measure forty-eight and three-quarters inches (48-3/4") from one end of the assembled purlin and mark the distance on the pipe.

**NOTE:** This first measurement is three-quarters (3/4) of an inch longer than the on-center rafter spacing to account for the length of purlin pipe that extends through the end purlin clamp of the first end rafter.

**FRAME ASSEMBLY (continued)**

4. From the location marked in the previous step, measure forty-eight inches (48") and make another mark on the assembled purlin.
5. Continue to mark the purlin in 48" intervals until all locations are marked. These marks help to maintain the 48" on-center rafter spacing of the shelter during assembly.
6. Repeat this procedure until all assembled purlins are marked.
7. After assembling all rafters and pre-marking the purlins, assemble the frame.

**ASSEMBLE THE FRAME**

After all ground posts are driven in place, rafters are assembled and purlins pre-marked, assemble the frame.

Gather the parts:

- All rafter assemblies and pre-marked purlins
  - Band clamps (#QH1402)
  - Cross connector (#102548)
  - 5/16" x 2-1/2" machine bolts and 5/16" nuts
  - Lifts, ladders, and assistants
  - Rope or cable
1. Carefully stand the *first end rafter*, slide a band clamp onto each rafter leg, and place the leg pipes in the first set of ground posts.

Brace the rafter in place to keep it straight. Depending on the frame size, a lift and additional assistants may be needed. Consult Quick Start section for details.



Rafter shown differs in design.

**ATTENTION:** Stand the rafter so the nuts and bolts of the end clamps are to the inside of the frame.

2. Secure the leg pipes to the ground posts using the 5/16" x 2 1/2" machine bolts and nuts.

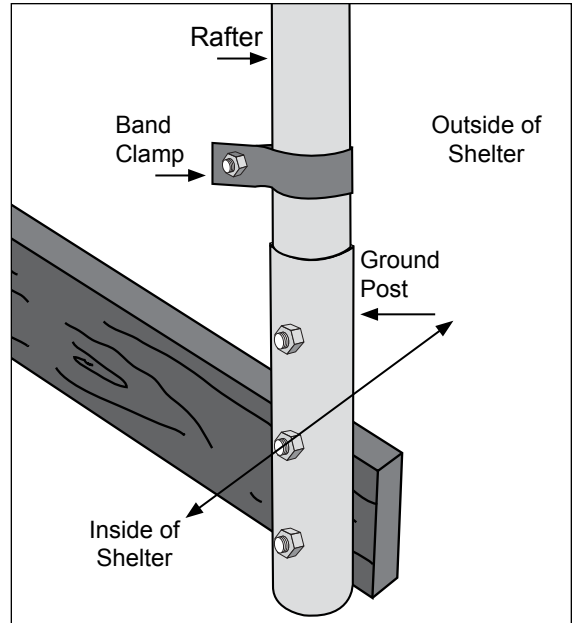

3. Use rope or cable to keep the rafter in position.



Rafter shown differs in design.

4. Carefully position the first interior rafter in place and secure the leg pipes to the ground posts.

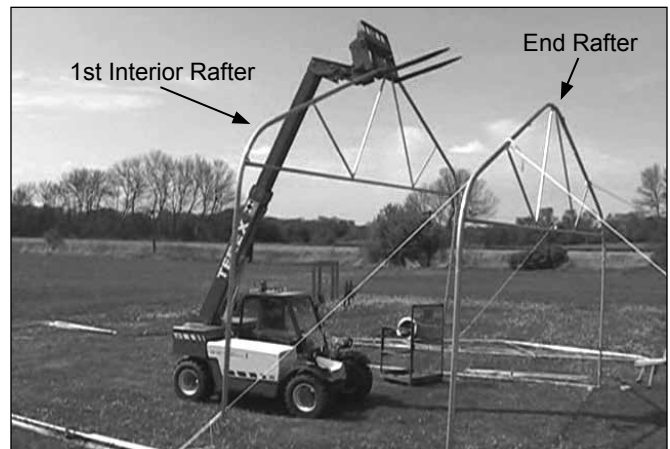

Rafter shown differs in design.

# GROWSPAN™ GOTHIC PRO GREENHOUSES AND SYSTEMS

## FRAME ASSEMBLY (continued)

- As the second rafter is steadied, remove one section of pipe from one assembled purlin.

**NOTE:** Work from the end of the purlin where the first measurement was taken during the pre-marking procedure.

- Insert the purlin pipe through an upper end clamp of the end rafter and through a cross connector placed in the same position on the *interior rafter*. Consult Quick Start section for purlin location per frame.

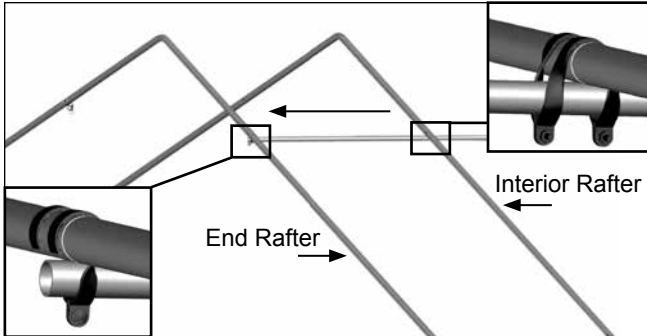

- Align the plain end of the purlin with the center of the end rafter and rotate the purlin pipe so that the first mark is visible (near the clamp of the interior rafter).

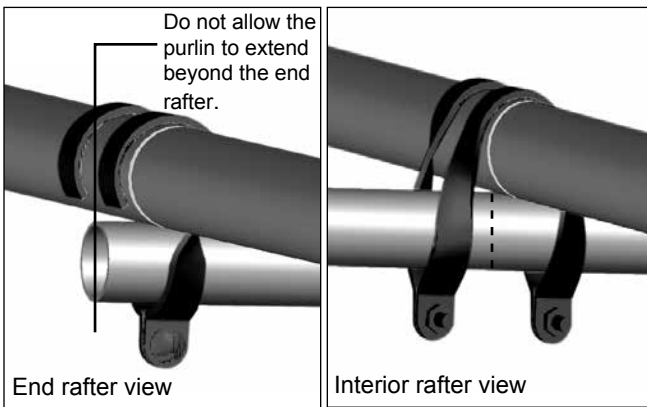

- Tighten the end clamp and secure it to the rafter with a Tek screw.
- Install Tek screw through end clamp and into the purlin pipe.

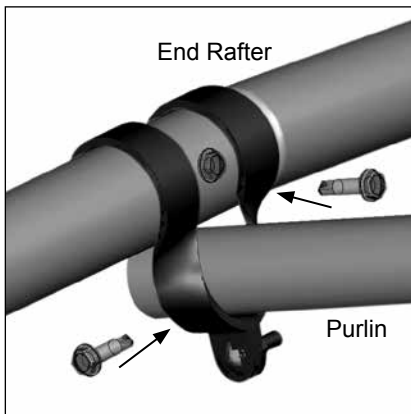

- Move to the interior rafter and align the mark on the purlin with the center of the rafter to maintain the proper spacing.

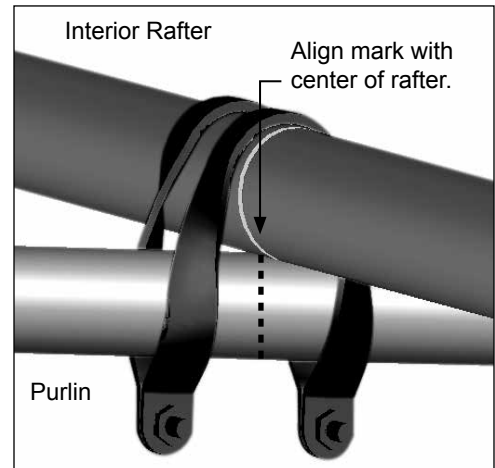

- Verify that the rafter spacing is forty-eight inches (48") on-center (adjust as needed) and tighten the cross connector.
- Secure the cross connector to the rafter using a Tek screw. See Quick Start section if needed.
- Repeat Steps 6-12 to install the first section of each purlin assembly for the first two rafters.

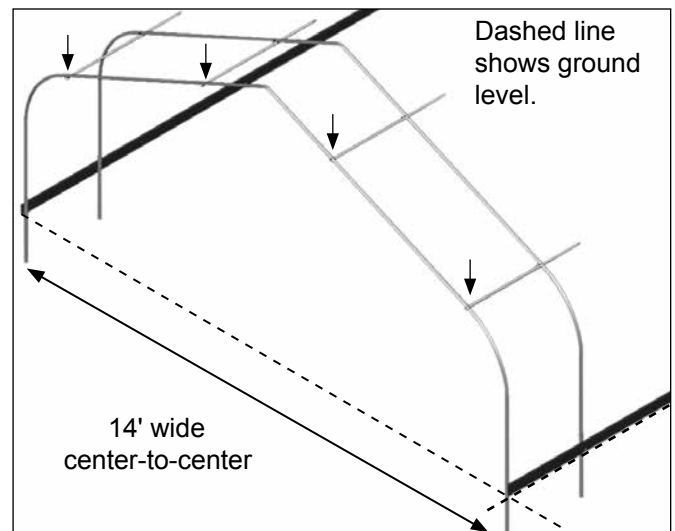

Frame shown may differ slightly from actual frame.

- Choose another interior rafter assembly and set it in position. **DO NOT USE THE REMAINING END RAFTER.**
- Secure the rafter legs to the ground posts as previously described and steady the rafter.
- Remove another section of purlin pipe from each pre-marked purlin assembly and attach these to the rafter.
- Verify that the distance between the rafters is 48" center-to-center. *Adjust the rafter forward or backward as needed to maintain this dimension.*

**FRAME ASSEMBLY (continued)**

18. Secure the purlin pipe joint with a Tek screw.
19. Repeat the above steps as needed to stand and secure the remaining interior rafters and purlins to complete the frame assembly.
20. Slide a band clamp onto each leg of the remaining end rafter, secure the rafter to the ground posts, and attach the purlins to it. Verify that the end clamps are positioned with the nut and bolt to the inside of the assembled frame. Refer to the Quick Start section and previous diagrams if needed.

**NOTE:** If the last end rafter is plumb and the purlin extends beyond the end of the rafter, cut the last section of purlin pipe to the required length.

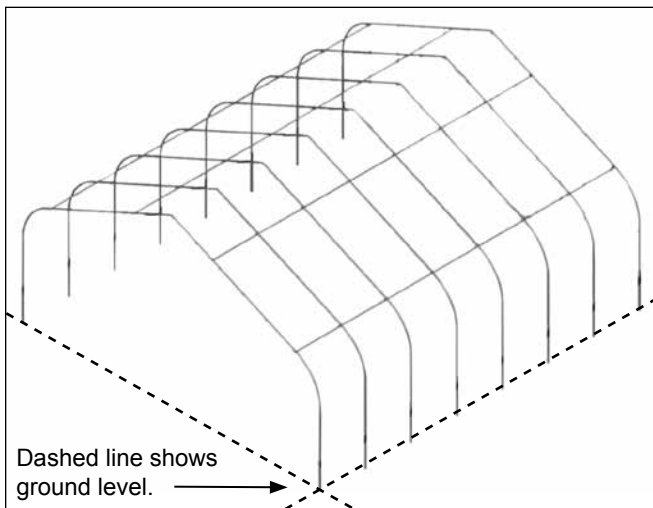

Frame shown may differ slightly from actual frame.

21. Once all rafters are set and all purlins are in place and secure, return to each pipe splice of each purlin and verify that a Tek screw is installed. Install a Tek screw if needed.
22. Remove any temporary bracing (if needed) and install the baseboards and the side struts.

**BASEBOARD INSTALLATION (RECOMMENDED)**

The baseboard (strongly recommended) is supplied by the customer and is attached at ground level along both sides of the frame. It helps keep the ground posts in place and also prevents the frame from working into the ground when anchored.

Attach the baseboards to the frame on the outside of the ground posts at this time.

**Gather the Parts**

- Treated or recycled plastic lumber (supplied by customer).
- 1/4" x 4" Carriage Bolts and 1/4" Nuts

**NOTE:** The following procedure describes one way to install the recommended baseboards. The size and type of the baseboard chosen may require the use of alternative steps. When properly installed, baseboards run the length of the frame.

On the outside of the frame, attach the first baseboard to the ground posts using the 1/4" x 4" carriage bolts and nuts. Continue adding baseboards to complete the first run. Splices are made between posts as shown. Use a short section of baseboard to secure separate baseboards at a splice.

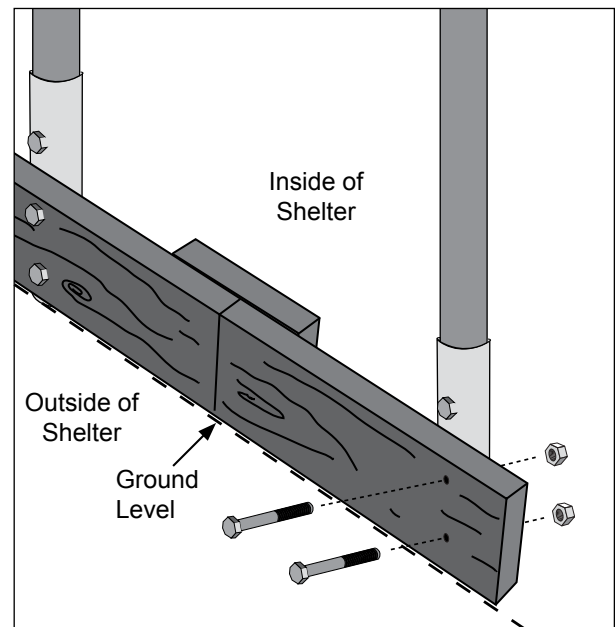

**NOTE:** The boards should be at ground level or slightly into grade to prevent the shelter from sinking and to create a seal along the bottom. After installing the baseboards, continue with these instructions.

If the recommended baseboard (customer-supplied) is not used, secure the required diagonal struts to the ground post using a Tek screw or other customer-supplied fastener. The installation of the diagonal struts is described as follows.

# GROWSPAN™ GOTHIC PRO GREENHOUSES AND SYSTEMS

## SIDE STRUT INSTALLATION

There are four (4) side struts for the shelter. These struts are positioned between the end rafters and the first interior rafter on each side of the shelter.

Complete these steps to install the four (4) side struts:

### Gather the Parts

- Struts
  - Band Clamps (#QH1402)
  - Lag screw or nut and bolt (supplied by customer)
1. Locate one strut and position it between one end rafter leg and the leg of the first interior rafter as shown below.

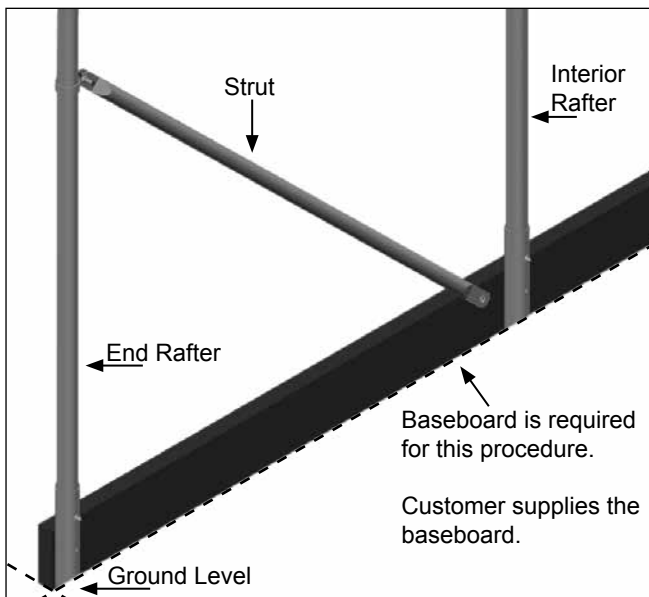

2. Attach one end of the strut to the band clamp as shown in the diagram below.

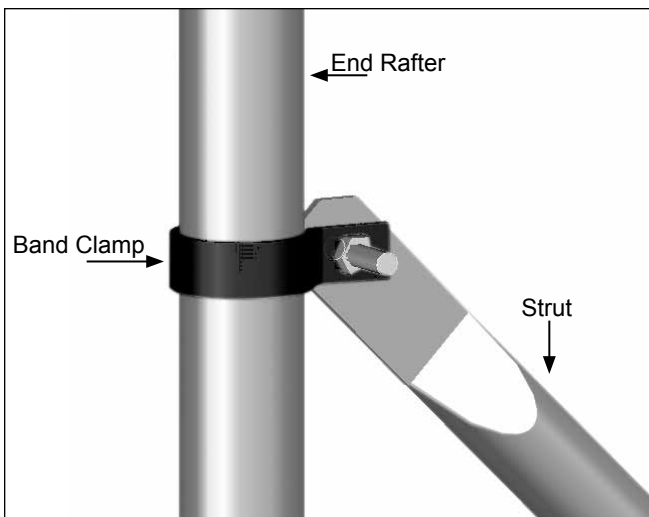

**NOTE:** Head of bolt on the band clamp must face the toward the outside of the shelter.

3. Attach the remaining end of the strut to the baseboard using a lag screw or nut and bolt (not included). See the diagram that follows for location.

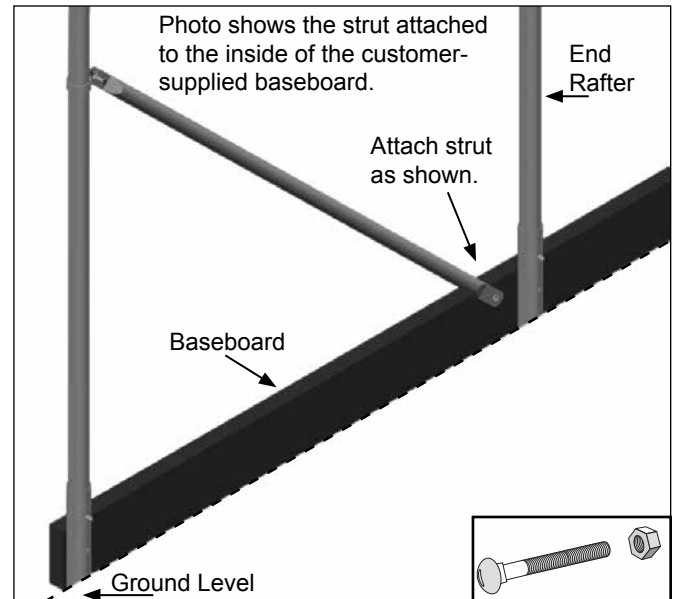

**NOTE:** A baseboard provides a place to attach each strut and helps keep the ground posts at the required depth. The customer is responsible for providing a baseboard for this frame. If no baseboard is present, attach the strut to the ground post using a Tek screw or other customer-supplied fasteners.

4. Repeat the above steps to attach the remaining side struts to the shelter.
5. After securing the struts, verify that all clamps are secured with a Tek screw to the rafters.
6. Verify that each pipe splice (purlin and rafter) is secured with a Tek screw.
7. Complete the next procedure to anchor the assembled frame.

### ANCHOR THE ASSEMBLED FRAME

At this point, anchor the greenhouse frame. Consult the MUST READ document for anchoring information and suggestions. Please call customer service at 1-800-245-9881 for additional anchoring information.

**CAUTION:** The anchor assembly is an integral part of the greenhouse construction. Improper anchoring may cause instability and failure of the structure to perform as designed. Failing to anchor the shelter properly will void the manufacturer's warranty and may cause serious injury and damage.

**END WALL INSTALLATION**

The steps to install the greenhouse end walls (front and back) are identical and include the following:

1. Install end wall framing. (See the diagrams in the Quick Start section at the back of these instructions. Read the installing accessories note below.)
2. Prepare polycarbonate end panels and attach.
3. Assemble doors and attach.

**INSTALL END WALL FRAMING (Front and Back)**

Site variations and different methods for anchoring the greenhouse may require slight changes to be made to these instructions. *It is the responsibility of the owner/ builder to adapt these instructions as needed to adjust for these and other differences.*

**A NOTE ABOUT INSTALLING THE END WALL FRAMING FOR OPTIONAL HEATERS, VENT FANS, AND MOTORIZED SHUTTERS (if equipped):**

Optional accessories such as heaters, vent fans and motorized shutter units are typically installed in the end walls of this greenhouse. Additional horizontal framing (included) is installed *between* the vertical end wall frame tubes to mount these accessories. The spacing shown for the end wall supports on the end frame diagrams may be too narrow for the installation of some larger accessories.

When framing the end wall, consult the installation instructions for the accessories (if equipped), or measure the width of the accessory to accurately space and position the end frame tubes.

Consult the panel installation diagrams in the Quick Start section to *identify the verticals that can be moved.*

**MOVE ONLY THE VERTICAL SUPPORTS LABELED AS NON-CRITICAL.**

*Before installing any greenhouse accessory, adhere to the following:*

- Consult the end frame diagrams before installing the accessory horizontal framing.
- Move only those verticals labeled as "NON-CRITICAL" on the end frame diagrams when deciding where to install the additional horizontal framing for accessories.
- Consult the diagrams in the Quick Start section showing the polycarbonate panel locations and the locations of the aluminum trim and profile before repositioning any end wall vertical.

- DO NOT REPOSITION THE END WALL VERTICALS USED AT THE SEAM OF TWO (2) POLYCARBONATE PANELS.
- Always consult the installation guides that shipped with the accessory for additional precautions, recommendations, and safety requirements.
- Before installing any electrical accessory, consult a professional electrician for precautions and additional assistance.
- For gas heaters, a professional, qualified service technician must install the unit.

*Complete these steps to install the accessory framing:*

1. Based on the installation requirements and precautions of the accessory, choose a location in the end wall to mount the accessory, and cut a 1.5" x 1.5" frame tube to the required length for framing.
2. Attach these horizontal frame tubes between the vertical frame tubes of the end wall (at the required height determined by the installation instructions included with that accessory) using angle brackets.

**INSTALL THE END WALL FRAME**

Refer to the end frame diagrams (Quick Start section).

The materials and parts needed to assemble the end wall frame include:

- Square Tube (#102897)
- Angle Brackets (#QH1330) & Band Clamp (#QH1402)
- Square Tube Fitting (#104624)
- Square-to-Round Tube Connect Bracket (#104074)
- Carriage Bolt (#FAH320) and Nut (#FALB32B)
- Tek Screws (#FA4482B)

1. Locate the square metal tubing for the base tube of the end wall. The base tube consists of two (2) 99" swaged tubes joined and cut to length. See Quick Start section for clarification.
2. Insert the swaged end of the tubing into the plain end to connect the pieces, measure, and cut to length.

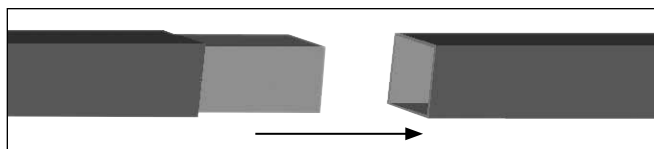

3. Position this assembled base tube on the ground between the legs of the end rafter at the front of the greenhouse and anchor it in place. This base tube will be directly below and in line with the end rafter.

## GROWSPAN™ GOTHIC PRO GREENHOUSES AND SYSTEMS

### INSTALL THE END WALL FRAME (continued)

- Secure the base tube between the legs of the end rafter using an angle bracket and Tek screws.

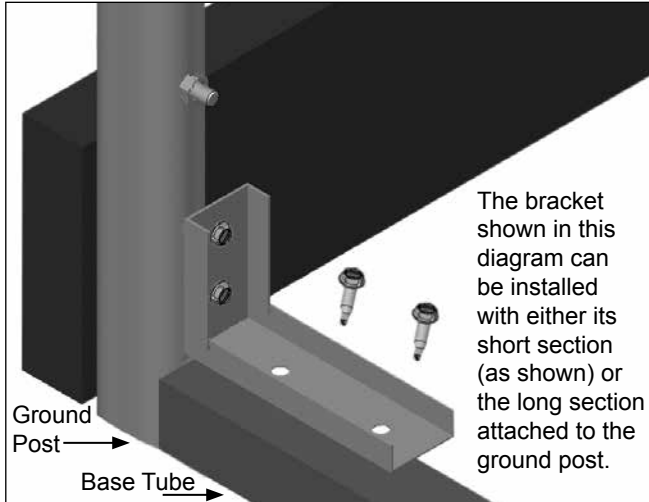

- On the base tube surface facing the inside of the greenhouse, install a short Tek screw at each joint and then locate and mark the center of the base tube.
- Consult the End frame diagram (Quick Start section) and *mark the rough opening for the width of the door assembly*.
- Place the band clamps on the end rafter above the door as shown below. **DO NOT TIGHTEN THE BOLTS AT THIS TIME.**

**ATTENTION:** The frame shown below may differ from the end wall frame. Consult the diagrams in the Quick Start section to view the frame for this shelter.

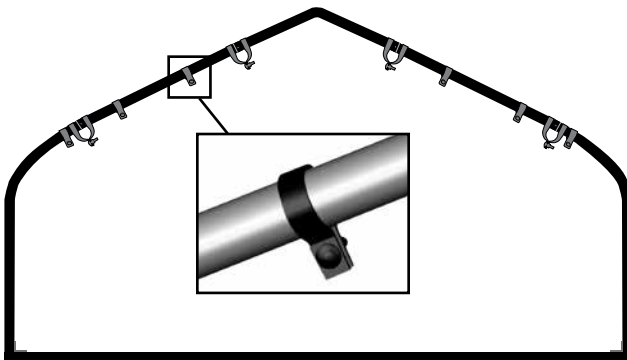

- Select the tubing for the two door jambs for the sides of the door. Each support includes:
  - One (1) long 99" section of square tubing (#102897 swaged end)
  - One (1) short section of square tubing (if needed). This is cut from a swaged end tube (#102897).
  - One (1) square-to-round tube bracket (#104074)

- Measure the distance *between the top of the base tube and band clamp (Step 7)* to determine the length of the first door jamb.

**NOTE:** If the measured length is longer than 99", an additional section of square tubing is required (see Step 10). If the distance is 99" or shorter, skip to Step 11.

- Choose one (1) square tube (#102897), insert the swaged end of the long tube into the plain end of another tube and tap with a hammer to properly seat the tubes at the joint.
- On the door jamb, mark the length determined in Step 9 (above) and *subtract the amount needed to account for the square-to-round tube connect bracket*, which is attached to the top of the door jamb. See the diagram that follows.

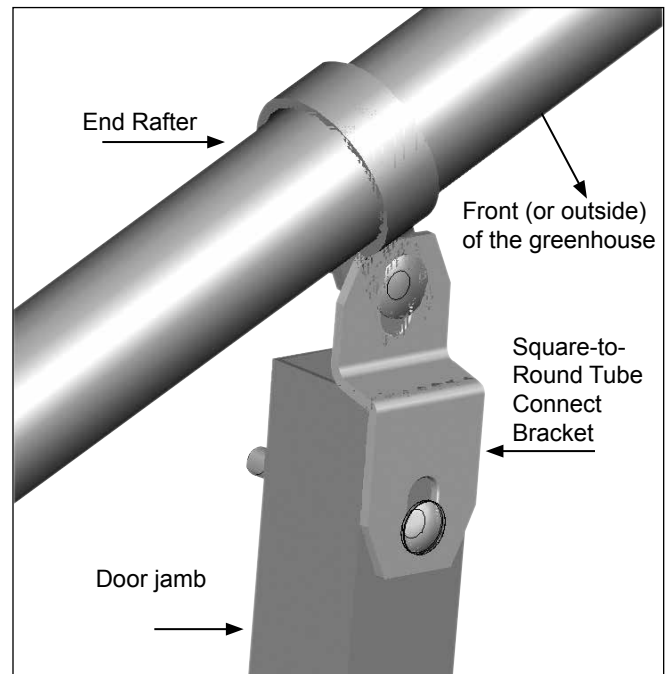

- Select a square-to-round tube connect bracket and attach the bracket to one end of the door jamb. Use a 5/16" drill bit to drill a hole through the tube and attach the bracket to the tube using a nut and carriage bolt.
- Repeat Steps 9-12 for the remaining door jamb.
- With the square-to-round tube connect bracket attached to the top of each door jamb, use the bolt in the band clamp to attach the bracket to the band clamp. **DO NOT TIGHTEN AT THIS TIME.**

**NOTE:** The heads of the bolts for each clamp are to the outside (or front/back) of the greenhouse. At this point, the two door jambs should be loosely attached to the end rafter assembly.

**INSTALL THE END WALL FRAME (continued)**

15. Using the marks on the base tube for the rough opening for the door (Step 6), *attach the bottom of one (1) door jamb to the base tube using an angle bracket.* Consult the end frame diagram.

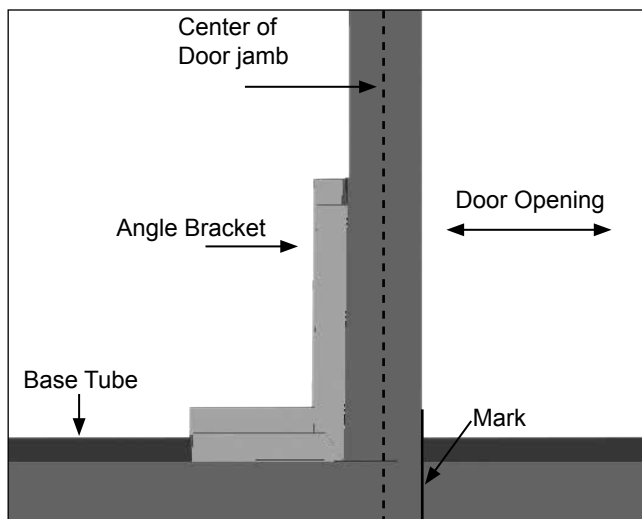

16. Using a level (or other means), verify that one door jamb is plumb and tighten the band clamp bolt to lock the first door jamb in place.
17. Take the door and set it in place on the bottom end wall frame tube between the secured vertical door jamb and the loose door jamb.

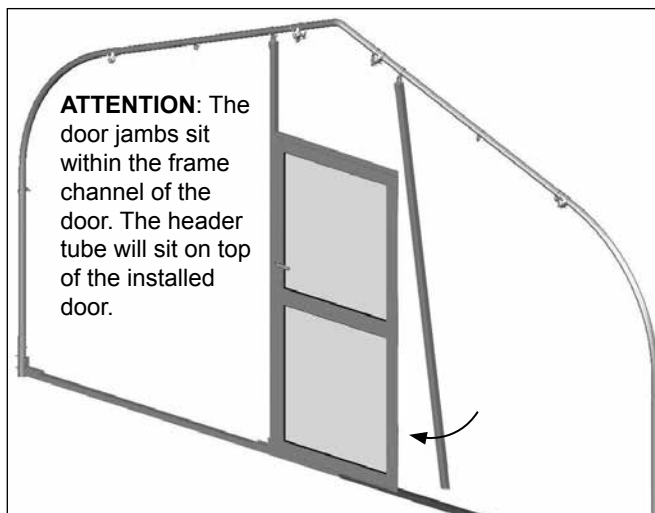

Frame shown may differ slightly from actual frame.

**ATTENTION:** The frame of the door is designed to "wrap around" the door jambs of the end wall. Diagram below shows how the door is installed.

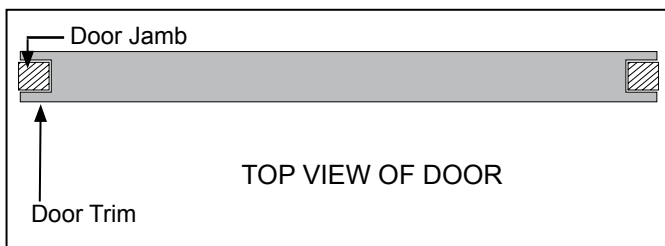

18. With the door centered in the rough opening, swing the loose door jamb back into position and secure the bottom of the door jamb to the base rail using Tek screws and an angled bracket.

**NOTE:** Verify that the door jamb is plumb before installing the Tek screws and adjust if needed.

19. Choose the square tube for the door frame header and cut the swaged end to the proper length for the width of the rough door opening.
20. Using two angle brackets, attach the header tube to the end wall assembly between the door jambs as shown below.

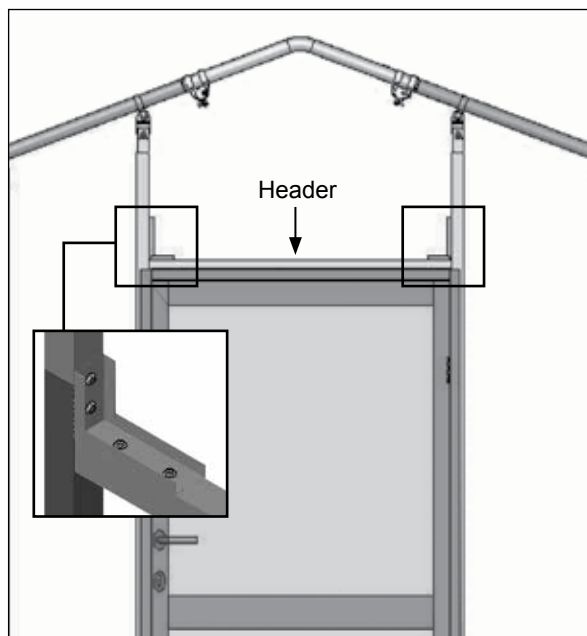

21. Verify that both door jambs are plumb and recheck the width of the door opening at the top and bottom. Adjust if needed.

**NOTE:** Do not secure the door to the door jambs at this time.

22. Use the end frame diagram to determine the number of remaining vertical end frame supports and place one band clamp on the end rafter for each of the remaining vertical supports. Use the diagram for the location of these clamps.
23. Using the end frame diagrams (Quick Start section), *measure and mark (on the base tube) the locations of the remaining vertical end wall supports.*

## GROWSPAN™ GOTHIC PRO GREENHOUSES AND SYSTEMS

### INSTALL THE END WALL FRAME (continued)

24. Choose the parts for each remaining vertical support for the end wall framing. Each vertical support consists of the following parts:
- Square tube: Longer verticals may require an additional shorter length cut from a longer tube.
  - One (1) square tube fitting (#104624) to attach the support to the base tube of the end wall assembly.
  - One (1) square-to-round tube connect bracket (#104074) to attach the tubing to the band clamp on the end rafter.
25. Use the steps presented earlier in these instructions and the end frame diagrams to measure and cut each section of square tubing for the remaining vertical frame members.

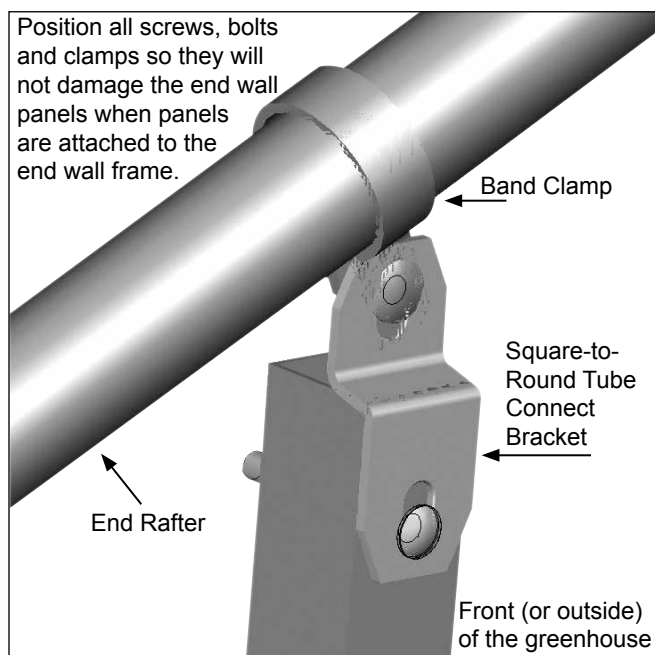

**ATTENTION:** Remember to subtract the amount needed to account for the square-to-round tube connect bracket that will be attached to the top of each remaining frame member.

26. Choose a square-to-round tube connect bracket and attach the bracket to one end of the vertical frame member. Use a 5/16" drill bit to drill a hole through the tube and attach the bracket to the tube using a nut and carriage bolt.
27. With the square-to-round tube connect bracket attached to the top of the frame member, place a square tube fitting on the bottom of the frame member.

28. Align the center of the assembled frame member with the center mark on the base tube and attach the top of the frame member to the band clamp on the rafter. Do not tighten.
29. Verify that the vertical end wall frame member is plumb and use the short Tek screws to secure the square tube fitting to the base tube.
30. Tighten the top band clamp and *install a short Tek screw through the clamp and into the rafter.*
31. Repeat the procedure as needed to assemble and install the remaining vertical end wall supports.
32. Return to the bottom of each frame member and install a short Tek screw through the back or side of each tube fitting to secure the end frame support to the tube fitting.

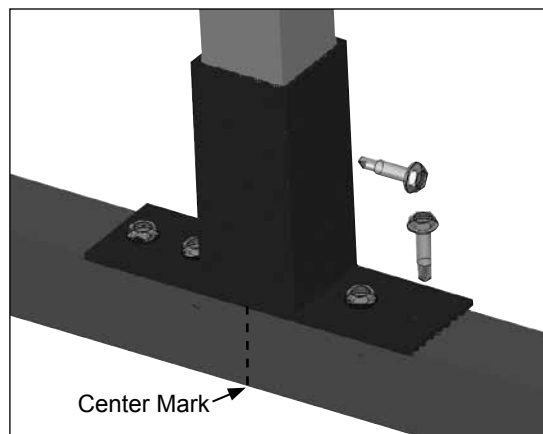

33. Once each end wall is assembled, return to each band clamp and pipe splice of each base tube and verify that a Tek screw is installed. Install a Tek screw if needed.

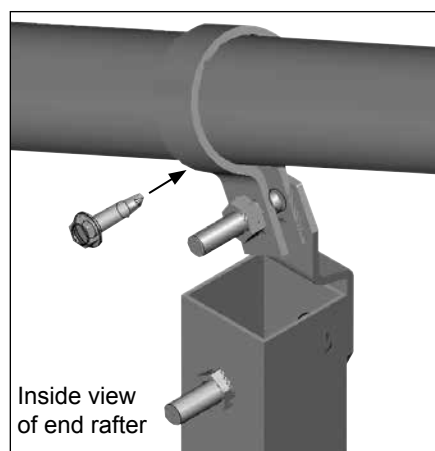

**INSTALL THE END WALL FRAME (continued)**

**INSTALL FRAMING FOR ACCESSORIES (OPTIONAL)**

Complete these steps to install the accessory framing:

1. Read the note regarding the installation of optional accessories at the beginning of the end wall installation section.
2. Based on the installation requirements and precautions of the accessory, choose a location in the end wall where you can mount the accessory, and cut two (2) 1.5" x 1.5" frame tubes to the required length. Consult the End Wall Diagram.
3. Attach these horizontal frame tubes between the vertical frame tubes of the end wall (at the required height determined by the installation instructions included with that accessory) using QH1330 brackets.



Space below reserved for customer notes.

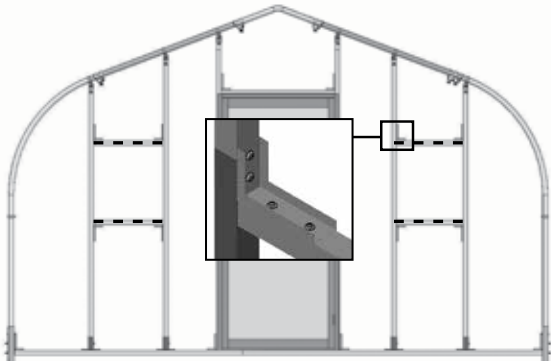

Dashed lines show where additional frame tubes are installed. If you are not installing any accessories the accessory framing is not needed.

**TAPE SHARP EDGES AND CONNECTORS**

After the frame is assembled, check the frame for sharp edges that could damage the cover or end panel, and file these smooth or tape over them using the supplied duct tape.

In addition, return to the rafters and apply tape over each connector to better protect the cover film when it is installed. The following photo shows one way to apply the tape.

Rafter and frame shown may differ from actual frame. Photo is used to illustrate how to apply tape.

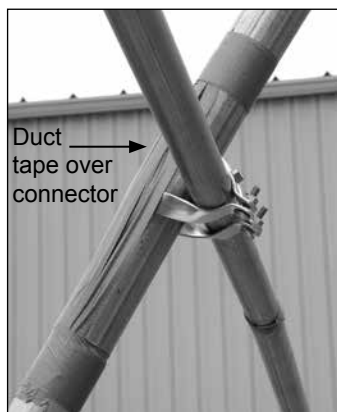

## GROWSPAN™ GOTHIC PRO GREENHOUSES AND SYSTEMS

### END PANEL INSTALLATION

After end wall framing is installed, attach polycarbonate panels. Steps that follow describe one way to complete the end wall panel installation.

Materials and parts needed to assemble end panels include:

- Polycarbonate panels and white vent tape
- Aluminum U-channel profile (104213)
- Aluminum End Cap profile (104548)
- Aluminum 8' H-channel (113236Z096)
- Tek screws (FA4484B)
- Neo-bonded, galvanized washers (102921B)

Read the following information before starting:

- U-channel profile is used to finish the sides and top edges of the polycarbonate panels.
- H-channel is used to join two (2) separate polycarbonate panels at the seam.
- Tek Screws and galvanized washers are used to secure aluminum channel and panels to end wall frame.
- Install the polycarbonate panels with the UV-protected side to the outside. Mark this side with a marker if needed after removing the protective film.

**ATTENTION:** The protective film must be removed from the polycarbonate panels. Allowing the film to remain intact and in direct sunlight will make the film difficult if not impossible to remove.

- During preparation, rest the edges of the panels on cardboard or other material to protect them from dirt and damage.
- Seal the bottom edge of the panels with white vent tape.
- Consult the polycarbonate panels (Quick Start section) for the location and lengths of each panel. The diagrams are located at the back of these instructions.

**ATTENTION:** Panels must be positioned as shown on the panel diagrams. Using a panel in the incorrect place can affect the placement of subsequent panels. In addition, the amount of aluminum profile used between panels and to finish the panel edges may not be adequate if additional seams are created. Begin at the *door end* of the building.

**NOTE:** Install all accessories (fans, vents, heaters, etc.) after installing all polycarbonate sheets.

Secure all polycarbonate panels as shown in the diagrams and photos below, unless otherwise noted.



Use a Tek screw and washer to secure panel to end wall frame. Do not crush panel when installing screws.

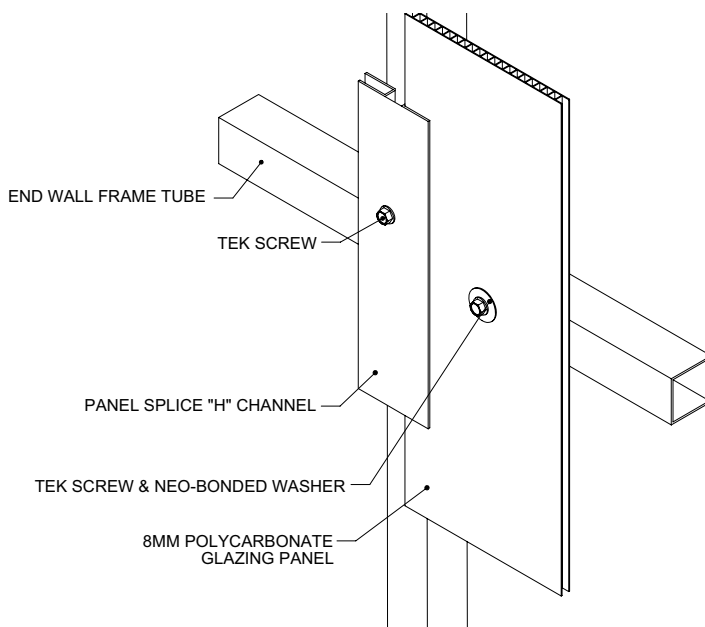
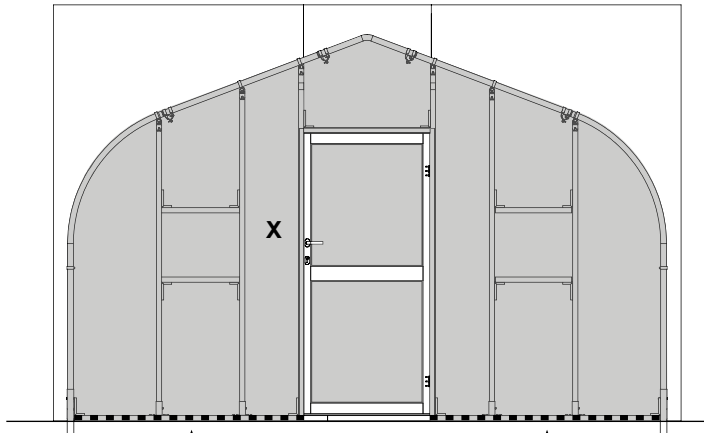

Diagram shows basic panel installation and fasteners used to secure polycarbonate panels. *Install H-channel with flat side out.*

**END PANEL INSTALLATION (continued)**

Complete following general steps to install end wall panels.

1. Consult panel location diagrams and select one 6' x 10' panel. When installing panels, begin at edge of door opening and work to the outside edge of end wall.



Dashed line and small arrows (above) show where to install the white vent tape.

**NOTE:** Upper end of panel is cut to length *after* attaching it to end wall frame and rafter.

2. Prepare the first panel for installation by removing protective film and marking UV-protected side with tape or removable marker.

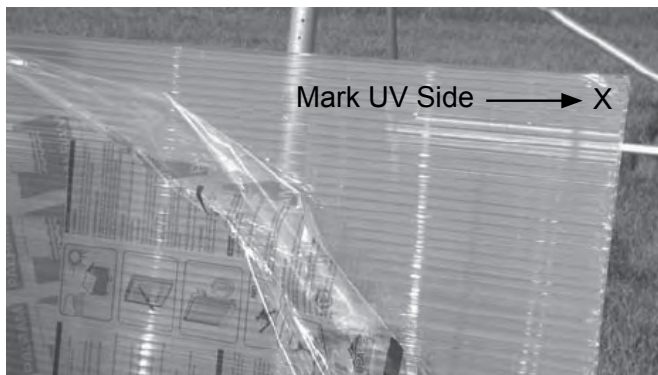

**NOTE:** Consult end wall diagrams located in Quick Start section for on-center dimensions. **Remember to account for installation of H-channel.**

**Some door designs allow for the installation of the adjacent panel behind door frame. Consider this when placing the panel into position.**

**NOTE:** Always remove protective film and mark and install UV-protected side to outside of greenhouse.

3. Apply white vent tape to bottom of panels and then install aluminum U-channel profile to panel edge adjacent to door as shown below and on Polycarbonate Panels diagram in Quick Start section.
4. Place in position, and attach to end wall framing using neo-bonded washers (102921B) long Tek screws (FA4484B).

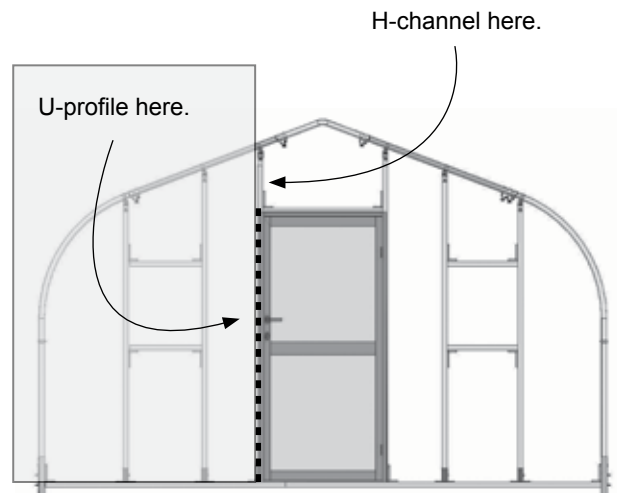

**NOTE:** Space screws evenly at **16"** when securing panels. **DO NOT USE WASHERS WHEN SECURING H-CHANNEL TO END WALL FRAMING.**

*Install H-channel with flat side out. It cannot be installed with channel side out as shown in photo. See diagram on previous page.*

# GROWSPAN™ GOTHIC PRO GREENHOUSES AND SYSTEMS

## END PANEL INSTALLATION (continued)

5. With panel secured in place, cut it to proper size using the rafter as a guide. *Panel can also be cut after all panels are installed.*

**Top of Panel:** In this photo, top of panel is removed using a power tool equipped with a round cutting bit. Greenhouse in photo used for illustration only. It is of a different model.

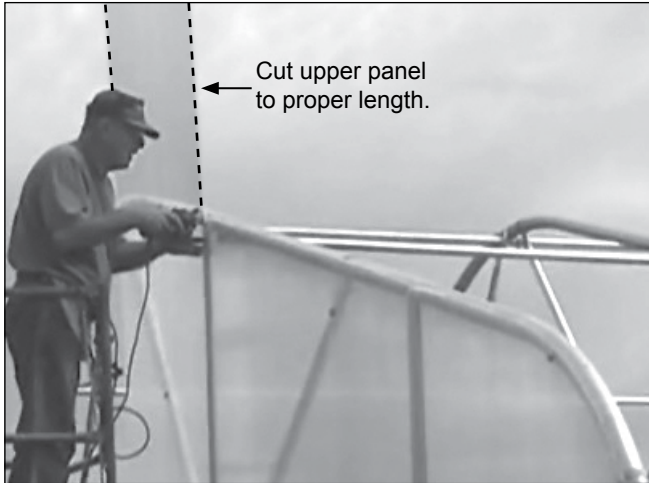

6. Take the 4' x 8' panel and cut a section to cover above door. Prepare as previously described. Remember to account for installation of adjacent panel and H-channel between panels.

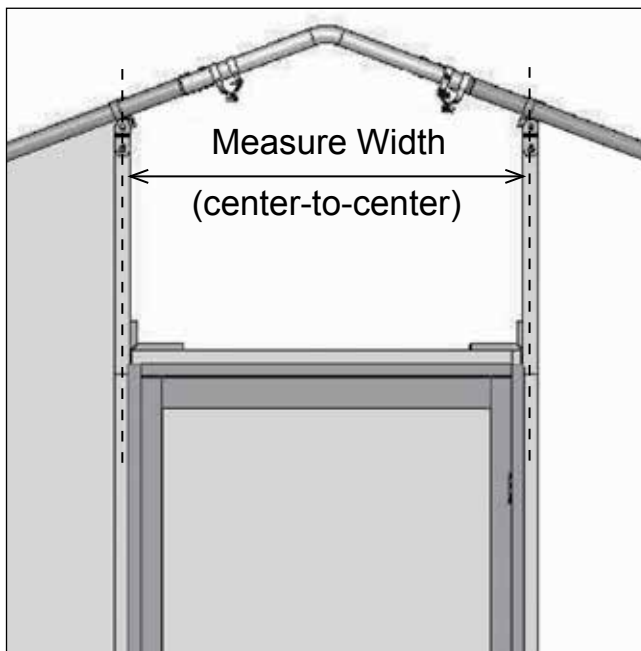

7. After cutting panel to proper width, measure and cut two sections of H-channel to correct length. H-channel is used to join two separate panels. *Install H-channel with flat side out.*

**NOTE:** Cut H-channel to a length that allows for installation of final piece of *aluminum U-channel*, which is installed at top of all end panels after panels are cut to proper height.

*H-channel must not interfere with cutting panel to correct length.*

8. Install one section of H-channel along each panel edge. Install H-channel flush with panel bottom.
9. Measure between *edges of H-channel* at panel bottom and cut a section of end cap profile (104548) to fit between H-channel.
10. Install end cap profile on bottom of small panel. *When installed, it will overlap top of door frame.*

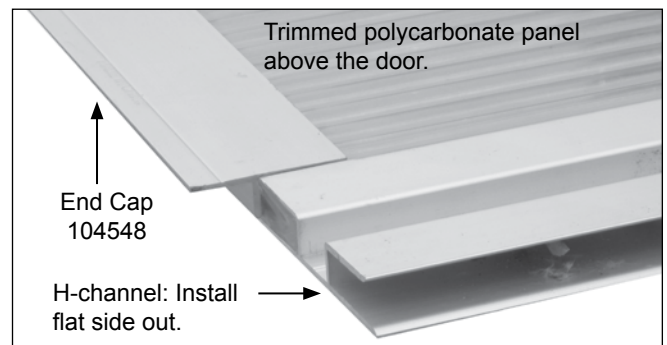

11. Using Tek screws (no washers), secure panel in place above door by installing a screw through center of H-channel and into frame member.

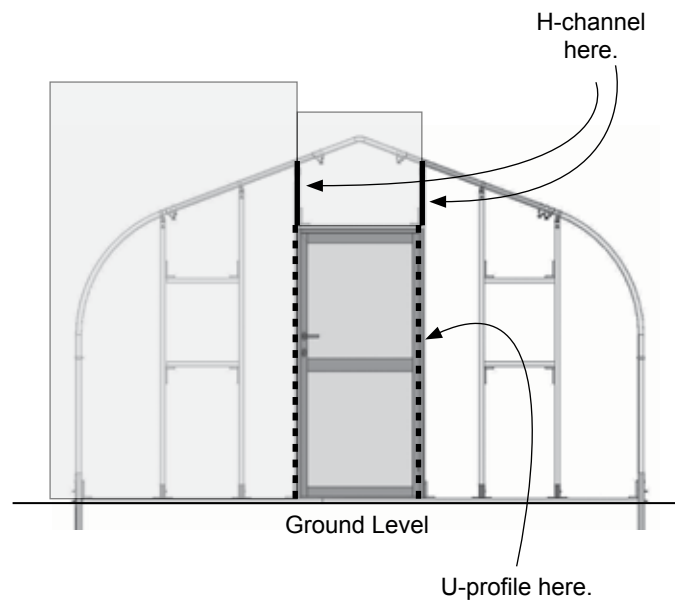

**NOTE:** H-channel must remain below top of rafter and short enough to allow for installation of final piece of aluminum profile. If necessary, remove panel, cut H-channel, and reinstall panel.

END PANEL INSTALLATION (continued)

12. Cut and prepare another 6' x 10' panel (as previously described) to cover remaining area of end wall.

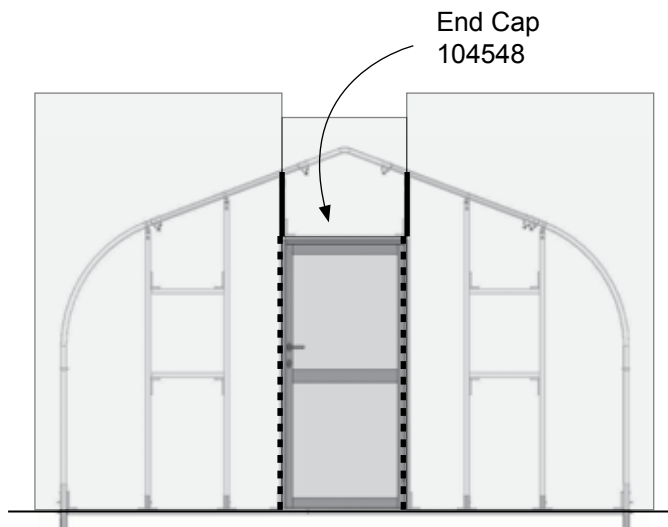

13. Place panel in position with its UV-protected surface to the outside and attach to end wall framing as previously described.

**ATTENTION:** The U-channel profile (104213) for top edge of all panels (dashed line below) is installed last and after all profile is installed along edges and between each panel.

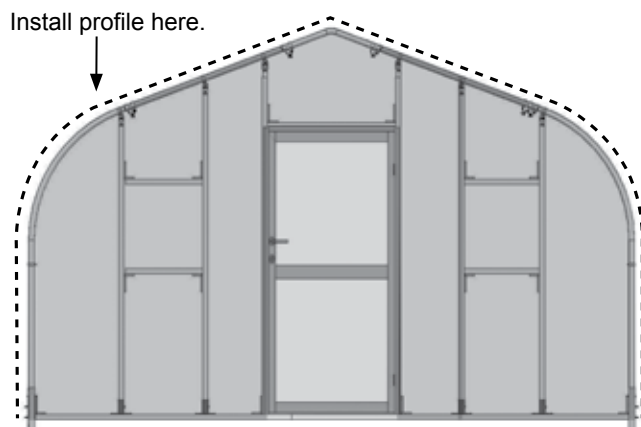

14. After installing all panels, cut and attach aluminum profile to remaining upper edge of all polycarbonate panels.

**NOTE:** For rounded panel edges, prepare U-channel profile as shown in photos that follow:



- a. Cut angled notches from aluminum profile to allow bending of profile. Position notches closer for tight curves.



- b. Distance between notches is determined by degree of bend required to fit rafter.

## GROWSPAN™ GOTHIC PRO GREENHOUSES AND SYSTEMS

### END PANEL INSTALLATION (continued)

- c. Bend U-channel at notches before installing it.



Space below reserved for customer notes.

15. Standing outside the door, install Tek screws through door frame and into end wall frame member to secure the door.

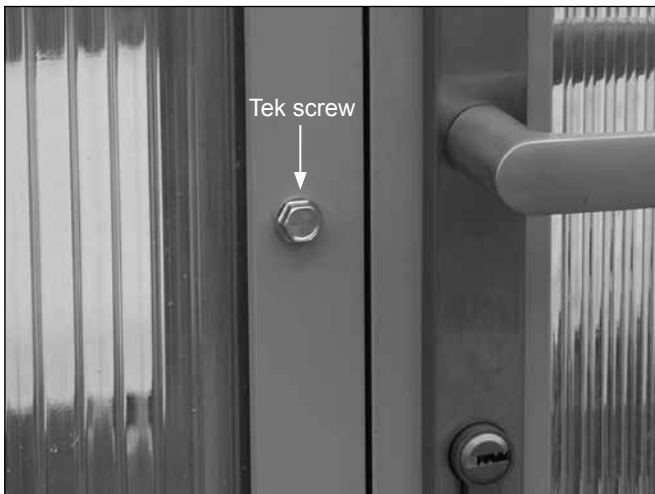

16. Repeat procedure (as needed) to install remaining end panels for other end of greenhouse.

**NOTE:** Consult Quick Start section for additional information.

17. Continue with **Main Cover Installation** procedures that follow.

**MAIN COVER INSTALLATION**

After the end panels and doors are installed, install the main covers. The steps to install the cover include:

1. Attach poly latch U-channel along the greenhouse sides and tops of the greenhouse *end rafters*.
2. Pull one cover film over the frame and attach to the end rafters.
3. Stretch and attach the first cover to the sides.
4. Install the Inflation Fan kit.
5. Attach a second cover layer to the frame.
6. Test the operation of the Inflation fan kit.
7. Install roll-up side kits and test.

**INSTALL POLY LATCH U-CHANNEL**

Gather the parts:

- Aluminum U-Channel (#102197)
- Ribbon board (supplied by customer)
- Tek screws (#FA4482B)

1. Measure the desired height to identify the top of the roll-up sides.

**NOTE:** For the roll-up side panel to function properly, the poly-latch channel attached to the sides of the frame must remain below the curve of the rafter.

Attaching a ribbon board (not included) to the rafters and then attaching the poly-latch U-channel to the ribbon board is recommended for the best results. Consult the diagram below for clarification.

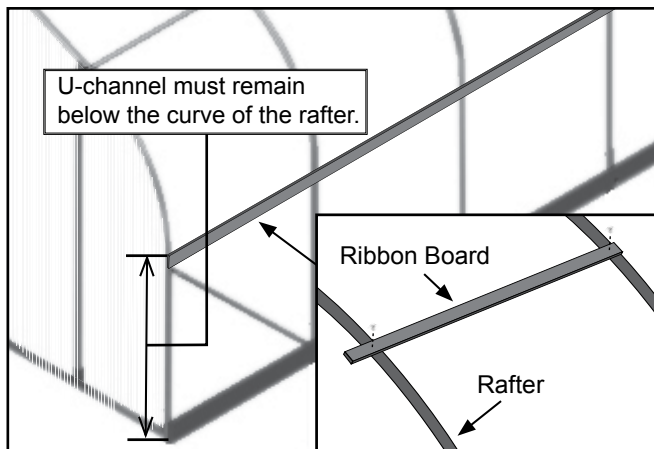

**NOTE:** Ribbon board and baseboard (recommended) shown in the diagram above *are not included* and are supplied by the customer.

2. Attach one section of the poly latch U-channel to the side of the frame using Tek screws. Attach U-channel flush with the outside edge of the end wall panels.

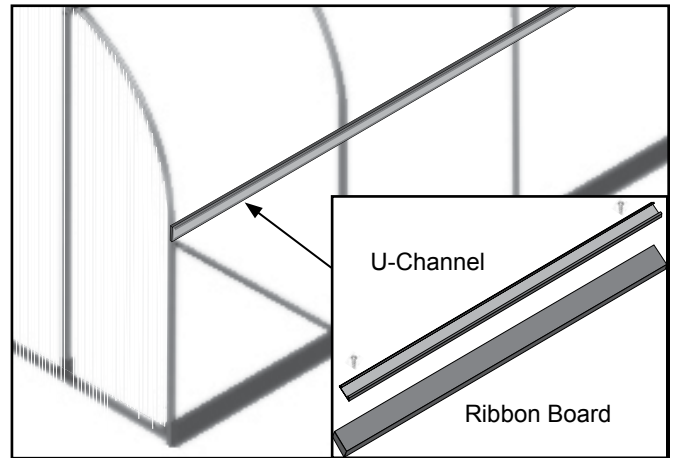

**NOTE:** The single poly latch is attached to the sides and tops of the end rafters.

3. Continue to attach the U-channel sections to the rafters (or ribbon board if used) and work toward the other end of the frame. Cut the last section of U-channel to the required length so that it is flush with the end wall panel (if needed).
4. Repeat these steps for the remaining side.
5. *After* attaching the U-channel to the sides of the frame, use Tek screws to attach the single U-channel to the top edge of the end rafters.

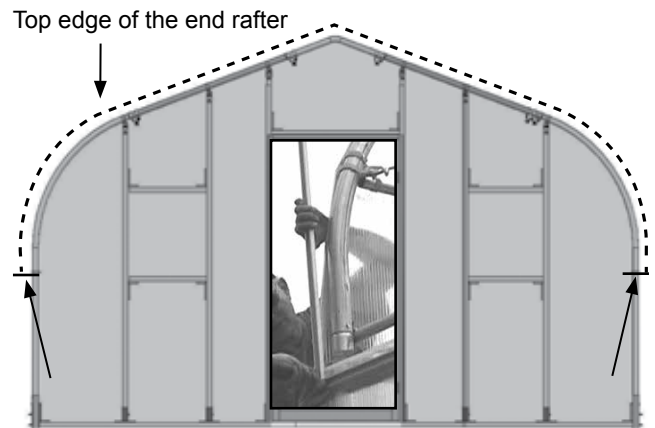

Location of the side runs of U-channel and ribbon board.

Insert shows the installation of poly latch U-channel on top of an end rafter. The poly latch U-channel will bend with the curve of the rafter as it is attached.

6. Continue to attach the U-channel until it has been installed on the top of *both end rafters*.

## GROWSPAN™ GOTHIC PRO GREENHOUSES AND SYSTEMS

### INSTALL MAIN COVER

Gather the parts:

- Main covers and inflation fan kit
- U-channel spring (#102198)
- Ropes long enough to reach over the frame (provided by customer)
- Box cutter or utility knife

#### Assembly Procedure

After the poly latch U-channel is attached to the frame, unpack the main cover and pull into place. Ropes or straps are typically used to pull the main cover onto and over the frame.

**⚠ WARNING:** To prevent damage to the cover and to prevent serious personal injury, DO NOT attempt to install the main cover on windy or stormy days.

Consult the Spec Sheets for cover identification. The greenhouse is equipped with double-layer main cover and an inflation fan kit. One cover is pulled into position and anchored to the frame, then the inflation kit is installed, and finally the last main cover is attached.

The steps that follow describe one way to complete this process.

**ATTENTION:** Install the IR film cover first! Examine the IR film and install with the correct side facing in the direction indicated on the film.

1. Take the cover film and position it along the base of one side of the greenhouse.



**NOTE:** Unfold the cover and locate the leading edge. The frame shown in the photos that follow differs from actual frame. Procedure is the same.

Photo shows the cover film in position to pull over the greenhouse.

2. Along the edge, make small holes in the cover at evenly spaced intervals and tie rope or straps to the cover. *May not be required for smaller greenhouses.*



**NOTE:** The ropes or straps must be long enough to reach over the top of the building to the other side. Long buildings require additional ropes to prevent tearing the main cover when it is pulled into place.

Keep the holes, used to attach the rope or straps, near the edge of the material and below where the cover will be secured to the U-channel.

3. After tying the ropes to the main cover, throw the ropes over the top of the greenhouse and pull the covers into place.

Use ropes to pull cover over the greenhouse and onto the frame. **ADDITIONAL ASSISTANCE IS REQUIRED.**

4. Center cover side-to-side and end-to-end.



**IMPORTANT:** To prevent damage to the main cover during installation, additional personnel and lifts may be needed. **Verify that you have installed the IR film according to the markings shown on the film.**

**INSTALL MAIN COVER (continued)**

5. Once the main cover is in place and centered, begin at the peak of one end and install the wire spring into the U-channel to secure the cover.

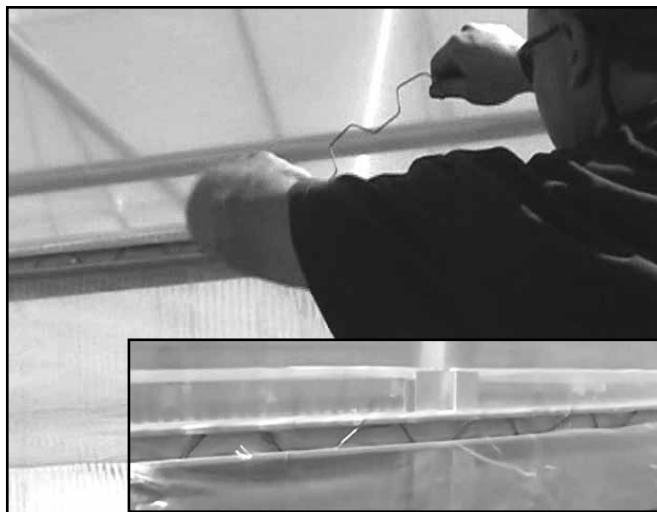

Photos show installing the spring into the U-channel on the outside of the greenhouse. The process is the same for the U-channel attached to the top of the end rafters.

**ATTENTION:** Center the main cover front to back and side-to-side to ensure that enough cover material is present to lock into the U-channel. The excess cover along each side is rolled up when the roll-up side assemblies are installed.

6. The rope can remain in place to temporarily secure the cover. Remove the ropes as the covers are secured to the greenhouse.
7. As the spring is install the spring into the U-channel at the top of the first end rafter, ensure that an even amount of the cover is exposed and maintained along the edge of the greenhouse.

**NOTE:** The cover material is cut longer/wider than is required to cover the greenhouse. For easier anchoring, allow approximately 10" to extend past the edge of the end rafter as the cover is anchored into place.

8. Continue down both edges of the first end rafter until the entire length of the end of the main cover film is secured in place.
9. Move to the other end of the building and repeat the steps to secure the main cover in the U-channel.
10. After the cover is stretched end-to-end and secured using the spring and U-channel, move to one side of the greenhouse and repeat the steps to anchor the cover film to the first side.

**NOTE:** Begin at one end of the U-channel and work toward the other. Another option is to begin at the middle of each side and work towards each end. Maintain an even length as working along the side. The final stretching of the cover will take place when the last side is secured.



Attach main cover to Poly Latch U-Channel.

11. After securing the first side, move to the remaining side, stretch the cover, and secure it in place.

**NOTE:** Pull the cover tight as the spring is inserted into the U-channel.

12. Once the first cover is stretched and secure, install the inflation fan kit in the desired location and according to the instructions sent with the kit.

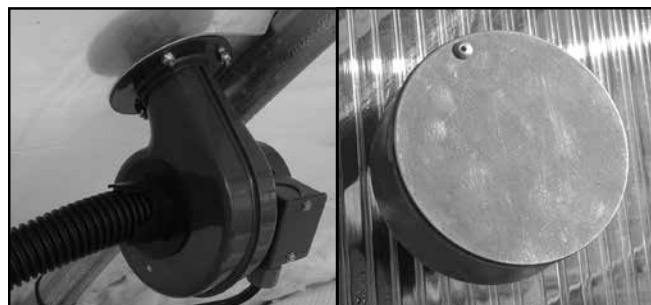

Install the Inflation Fan Kit *before* installing the second main cover. Consult the instructions included with the Inflation Fan Kit to install the kit.

## GROWSPAN™ GOTHIC PRO GREENHOUSES AND SYSTEMS

### INSTALL MAIN COVER (continued)

13. After installing the inflation fan kit, repeat the steps to install the film for the second main cover.

**NOTE:** When installing the second cover film, use the same U-channel used for the first cover film, and a second run of spring, which is installed on top of the first U-channel spring already in the channel.

The excess material along the sides is rolled up in the roll-up side assembly.

14. With the second cover film layer installed, test the operation of the inflation fan kit.

**IMPORTANT:** If trimming the excess cover material at the ends (not the sides), DO NOT remove too much of the excess material.

Some excess main cover material (the material that extends beyond the end rafters) should remain in place to more easily re-stretch the film if needed.

15. Continue with the Install the **Roll-up Side Assemblies** procedure.

### INSTALL THE ROLL-UP SIDE ASSEMBLIES

The instructions below describe how to install a single roll-up sidewall assembly for one side of the frame. The procedure is repeated for the remaining side.

The procedures to install the roll-up side include the following:

1. Assemble the roll-up side conduit.
2. Attach the roll-up conduit to the bottom of the main cover along the sides.
3. Assemble the Twist-of-the-Wrist assembly and attach it to the frame and the roll-up side.
4. Install the Anti-Billow Rope system.
5. Test the operation of the roll-up side.

### ASSEMBLE THE ROLL-UP SIDE CONDUIT

Gather the Parts:

- Pipe 1.315" x 75" swaged 17 GA (#131S0075)
- Pipe 1.315" x XX" plain 17 GA (#131P0XX)
- Tek screws (#FA4482B)

The roll-up side conduit assembly is attached to the bottom of the roll-up side cover material. This assembly runs the length of the frame and serves as the center pipe that the roll-up cover wraps around when it is opened to ventilate the shelter. *This conduit is identical to the purlins that were assembled and attached to the frame.*

**NOTE:** The number of pipes used in the roll-up conduit assembly varies with the length of the greenhouse.

Roll-up conduit assemblies consist of multiple sections of swaged 1.315" pipe at 75" in length (part #131S075) and one (1) additional plain 1.315" pipe at a shorter length (part #131P0XX) determined by the greenhouse, where XX represents the remaining length required to complete the roll-up conduit assembly and to reach the end of the greenhouse.

Complete these steps to assemble the roll-up side conduit.

1. Locate all sections of pipe needed to assemble the cover conduit.
2. Insert the swaged end of each pipe into the plain end of another pipe until the conduit is assembled.
3. Secure each pipe joint with a Tek screw.

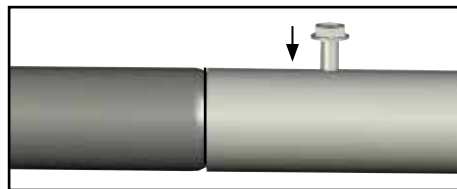

4. Place the assembled conduit at the base of the side where the end of the main cover is located.

**NOTE:** Apply duct tape over Tek screws to prevent damage to main cover.

5. Repeat the steps to assemble the remaining cover conduit.
6. Continue with the procedure that follows to attach the conduit to the main cover.

**ATTACH CONDUIT TO MAIN COVER ROLL-UP SIDE**

Gather the parts:

- Assembled conduits
- Fabric clips #CC6212 (Divide quantity in half.)
- Tek screws (#FA4482B)

To this point, the main cover layers are secured to the greenhouse and the roll-up portion of the main covers along both sides are secured to and hanging down from the poly latch U-channel.

1. Unfold the remaining portion of the main cover (if needed) and evenly stretch it out on the ground along the frame.
2. Working from the inside the frame, roll the assembled cover conduit onto the edge of the main cover.
3. Verify that the cover and conduit are evenly positioned and tuck the cover edge under the conduit and begin to turn the conduit in a clockwise direction.

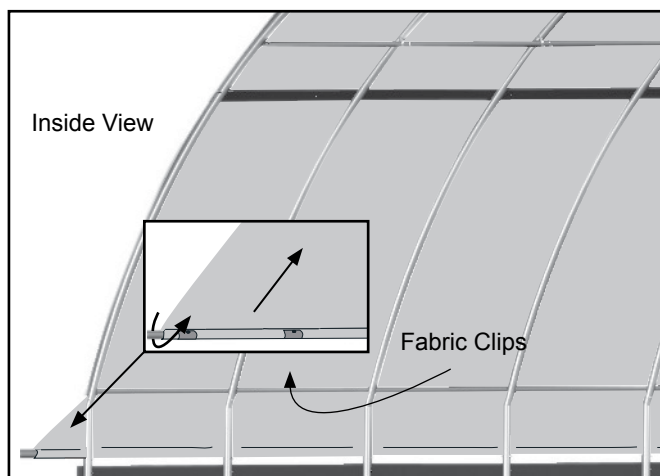

Diagram may show a different model and is used for illustration purposes only.

4. Secure the cover material to the conduit using Tek screws and fabric clips evenly spaced along the conduit. (May not be needed if cover film remains tightly wound around conduit.)
5. Continue to roll the conduit until the excess cover material is wound around the conduit.
6. Repeat these steps for the other side of the shelter.
7. With the excess cover material rolled up on the conduit assemblies, continue with the **Twist-of-the-Wrist Assembly** procedure.

**TWIST-OF-THE-WRIST ASSEMBLY**

Gather the parts:

- Aluminum channel
- Drive handle
- Gearbox and gearbox drive
- Mounting plate
- Bearing and threaded rod
- 3/8" nuts and washers

The Twist-of-the-Wrist Assembly is designed to roll up a portion of the sides of the structure. The following steps describe the assembly and its installation.

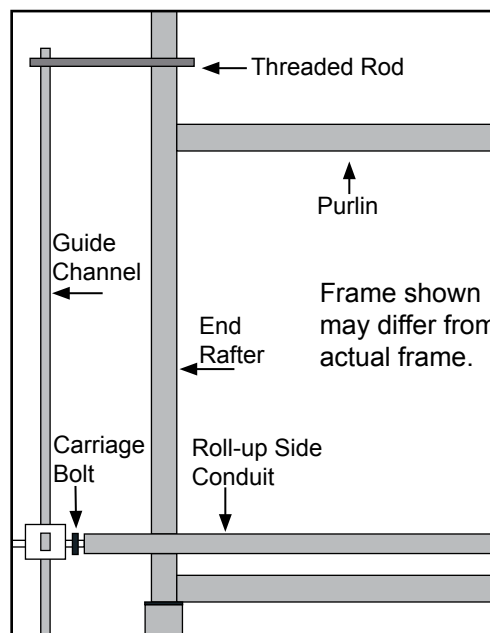

1. Drill a 5/16" hole through the cover conduit 1/2" from the end of the conduit.
2. Insert a tubing adapter into the conduit and align the holes of the adapter with the drilled holes in the conduit.



# GROWSPAN™ GOTHIC PRO GREENHOUSES AND SYSTEMS

## TWIST-OF-THE-WRIST ASSEMBLY (continued)

3. Select the aluminum channel and drill a 3/8" hole through the channel approximately 2" from the end and attach a threaded rod using a 3/8" nut on each side of the channel.

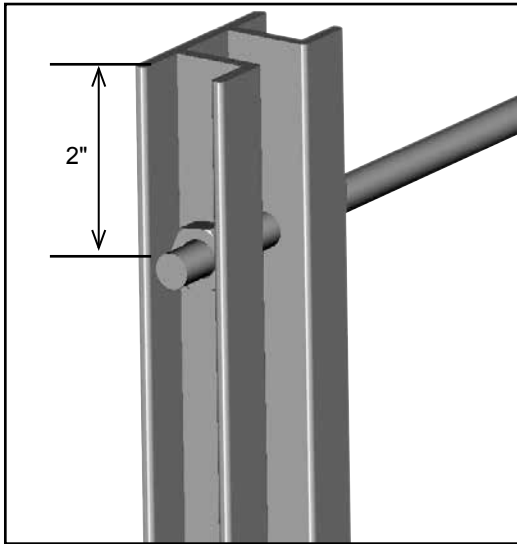

4. With lower end of the channel approximately 4" off the ground, position the channel along the rafter at the end of the building where the Twist-of-the-Wrist assembly will be located.
5. Secure the upper end of the channel by drilling a 3/8" hole through the end rafter and attach as shown. The lower end of the channel will "float" and is not attached.

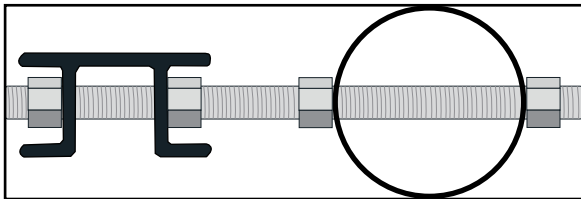

Top View

**NOTE:** Install a flat washer between the nut and the end panel.

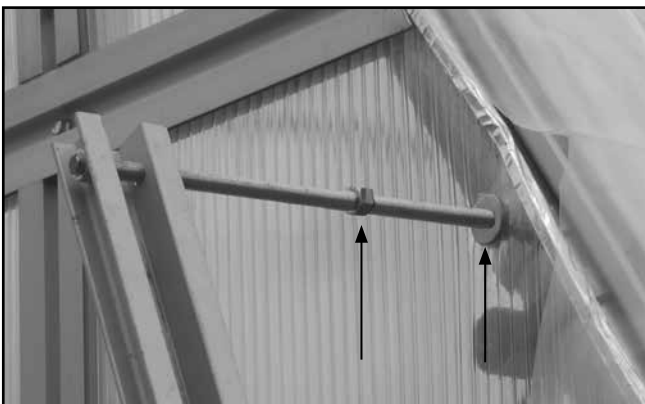

6. Select the bearing bracket and attach the bearings as needed. (In some instances, the bearings may come already attached.) Assemble as follows:

**NOTE:** Single bearings are attached to the sides of the bracket and double bearings to the middle portion of the bracket. Use 1/4" hex bolts and locknuts as needed. Install a flat washer on both sides of each bearing to insure proper operation of bearings and the assembly.

7. Install the longer bolts with bearings on the side of the bracket that has the two holes. Install these *before* installing the double bearing assemblies. See the figures below.
8. For the spacers on the long bolts, insert a 5/16" nut over each bolt. *These nuts are used as spacers only.*

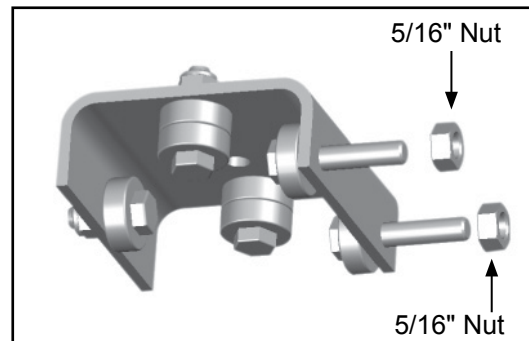

9. Slide the Twist-of-the-Wrist mounting plate over the long bolts and secure the plate with two lock nuts.

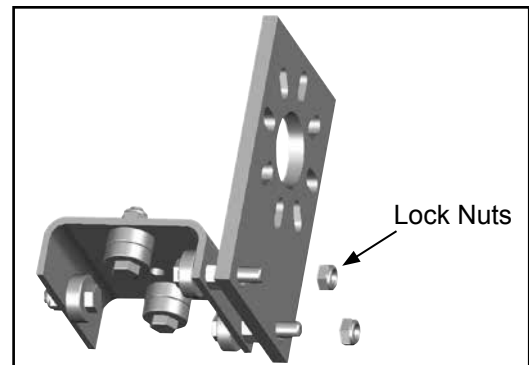

10. Attach the Twist-of-the-Wrist gearbox to the mounting plate using hex head bolts.

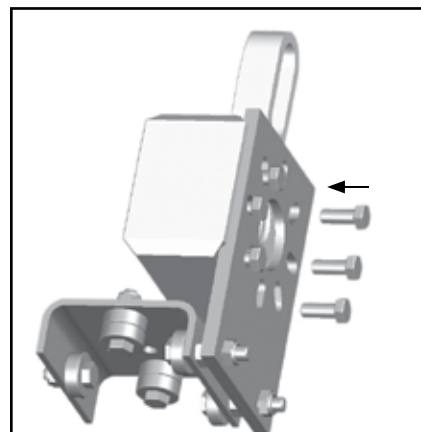

**TWIST-OF-THE-WRIST ASSEMBLY (CONTINUED)**

11. Using a carriage bolt, attach the square shaft to a tubing adapter.



12. Slide the square shaft through the Twist-of-the-Wrist gearbox.

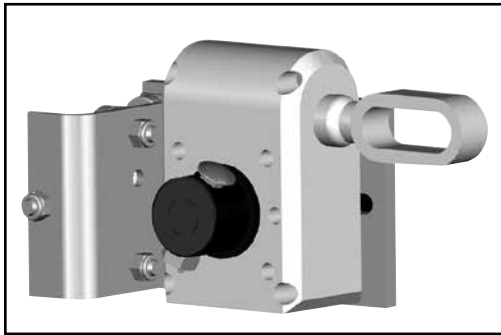

13. Slide the Twist-of-the-Wrist assembly onto the aluminum channel from the ground end. (This is the free end of the channel.)

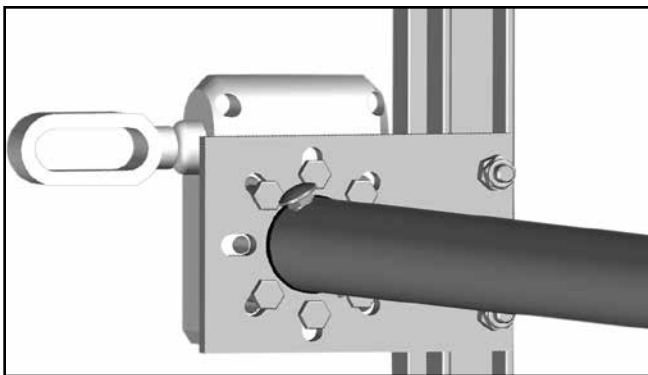

14. Finish rolling the cover conduit in a clockwise motion up to the Twist-of-the-Wrist assembly.

15. Attach the rolled conduit to the square shaft of the assembly by inserting a carriage bolt through the hole in the conduit and tubing adapter. Tighten the nut.

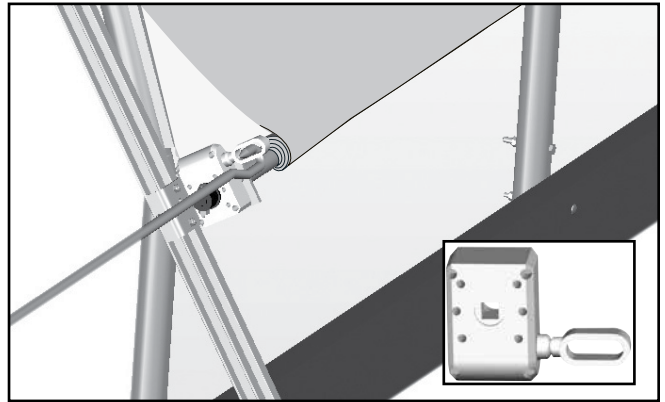

16. Attach the crank handle to the Twist-of-the-Wrist assembly. (End panel is not shown in the above diagram.)

17. Test the operation of the Twist-of-the-Wrist assembly and repeat the steps for the remaining assembly.

**NOTE:** If the cover rolls in the desired direction, but you want to turn the crank in the opposite direction for the same result, unbolt, reposition the gearbox, and remount it on the same side of the mounting bracket.

**INSTALL ANTI-BILLOW ROPES**

Gather the Parts:

- Eyebolts
- Anti-Billow rope
- Nut and washers

Anti-billow ropes secure the roll-up sides when they are in the down position. Complete the following steps to install the ropes. Repeat the steps for the remaining side.

**TO PREVENT DAMAGE AND POSSIBLE INJURY, INSTALL THE ANTI-BILLOW ROPES IN SHORT LENGTHS ALONG EACH SIDE OF THE FRAME.**

**DO NOT INSTALL AS A SINGLE LENGTH TIED AT EACH END OF THE BUILDING. DOING SO WILL RESULT IN A LOOSE SIDE PANEL IF THE SINGLE ROPE BREAKS DURING STRONG WINDS.**

**ATTENTION:** The procedure that follows is applicable when the frame was constructed using wood boards under each rafter foot, or if baseboards were installed. If the shelter was constructed on concrete footings, a concrete slab, or on bare ground, alternative steps must be taken by the owner during the following procedure to anchor the lower ends of the anti-billow ropes. *Additional parts may be required and must be supplied by the customer.*

## GROWSPAN™ GOTHIC PRO GREENHOUSES AND SYSTEMS

### INSTALL ANTI-BILLOW ROPES (CONTINUED)

1. Using the Twist-of-the-Wrist assembly, roll up the sidewall so that it is a few inches above the ground.
2. Drill a 3/8" hole through the baseboard at the base of the end rafter where the Twist -of-the-Wrist assembly is located, insert an eyebolt through the hole, and secure the eyebolt with a nut and washer.

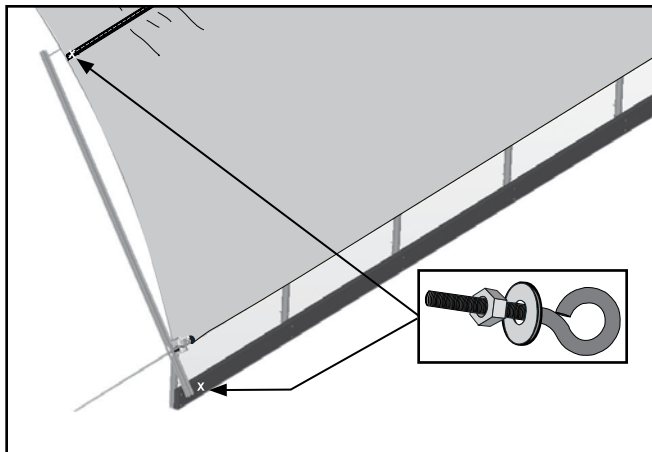

Diagram may show a different frame used for illustration purposes only.

**ATTENTION:** If no wood baseboard is present as required, additional steps must be taken to anchor the lower portion of the anti-billow ropes.

3. Move up the same end rafter and install the second eyebolt through the poly latch U-channel and rafter leg.

**NOTE:** If the poly latch U-channel was attached to a ribbon board (as suggested), the eyebolt can be mounted through the poly latch channel and ribbon board.

4. Attach the remaining eyebolts using the diagram below as a pattern guide.

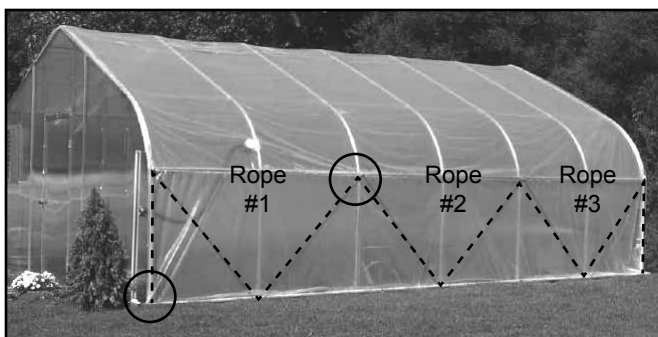

Example: Circles identify the ends of Rope #1.

5. Once all eyebolts are installed in the proper locations, install the anti-billow rope **in short lengths along each side**. Thread the free end of the rope through the end rafter eyebolts and the eyebolts at two to three interior rafters.
6. Cut the rope and tie one end to the eyebolt.

7. Pull the rope tight and tie the remaining end to secure.
8. Repeat the steps to install another section of anti-billow rope. Continue this pattern until all ropes are tied along one side and repeat the steps to install the anti-billow ropes for the remaining side.

**NOTE:** The number of individual ropes along any one side depends on the length of the building, rafter spacing, and the length of the rope sections.

9. Check the roll-up side operation.
10. Read the shelter care and maintenance information that follows.

### SHELTER CARE AND MAINTENANCE

Proper care and maintenance of the shelter is important. Check the following items periodically to properly maintain the shelter:

- Regularly check the cover or covers to see that these are tight and in proper repair. Tighten and adjust the tension as needed to prevent damage and wear.
- Check connections and all fasteners to verify that they remain tight and in good condition.
- Check the polycarbonate panels to verify that these are secure and in good repair. Verify that nothing is touching the panels that may cause damage.
- Do not climb or stand on the greenhouse at anytime.
- Remove debris and objects that can accumulate on the greenhouse. Use tools that will not damage the cover when removing debris.
- Remove snow to prevent excess accumulation. Use tools that will not damage the cover when removing snow.
- Check the contents of the shelter to verify that nothing is touching the cover that could cause damage.
- If the shelter is dismantled and moved, inspect all parts and connections before using.
- Depending on the contents, construction of the shelter, shelter materials, and shelter location, the potential for condensation exists. GrowSpan™ offers several items that can be used to alleviate a condensation condition. Please contact a GrowSpan™ representative for additional information.
- For replacement or missing parts, call 1-800-245-9881 for assistance.



**QUICK START GUIDE**

14' Wide Gothic Pro Greenhouse

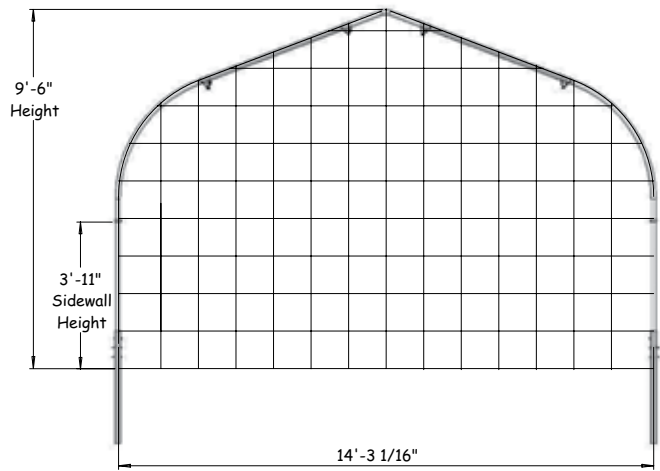

**FRONT**  
Grid Represents 12" Squares

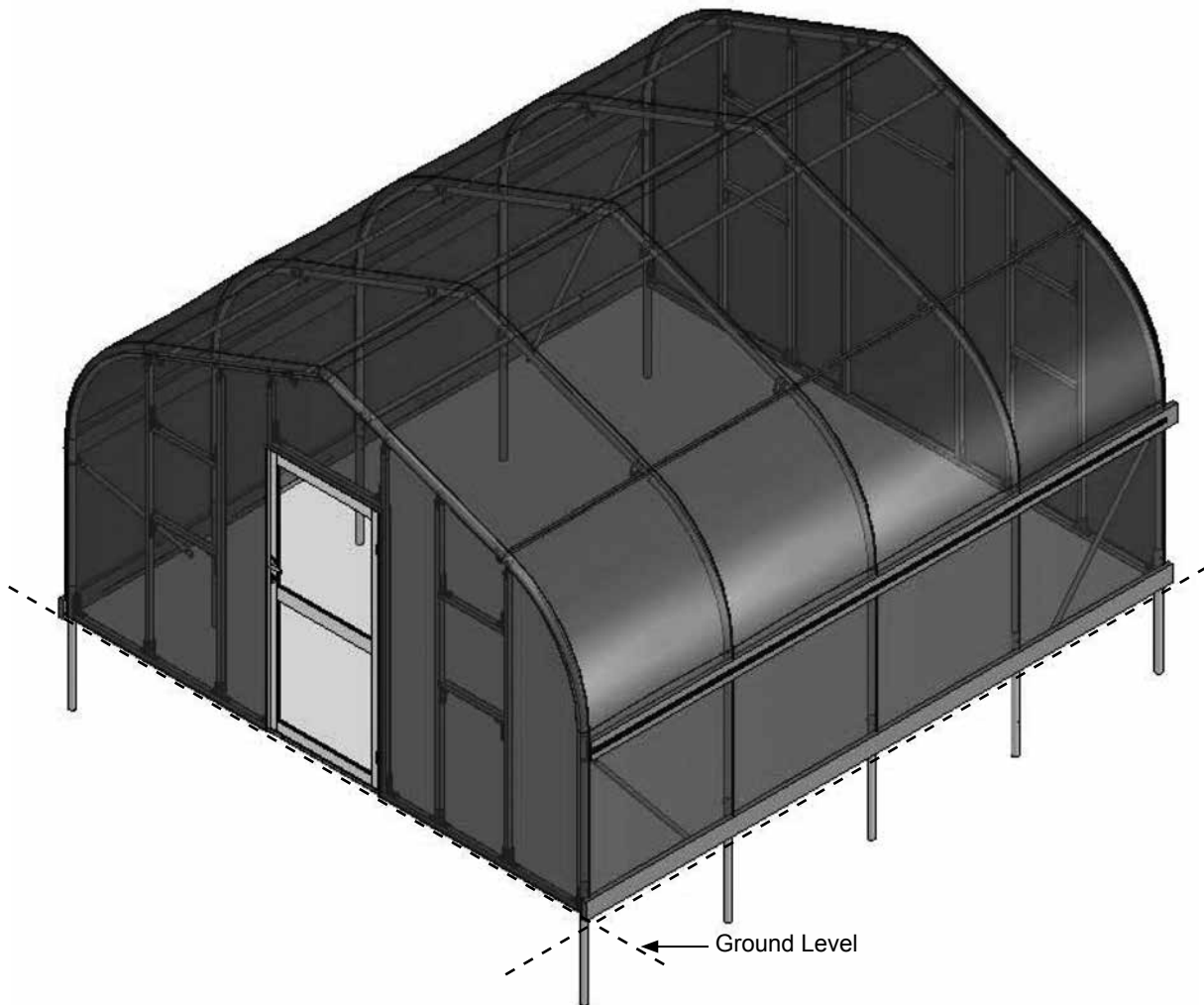

Frame shown may differ in length from actual frame.



# SIDE PROFILE - 104840

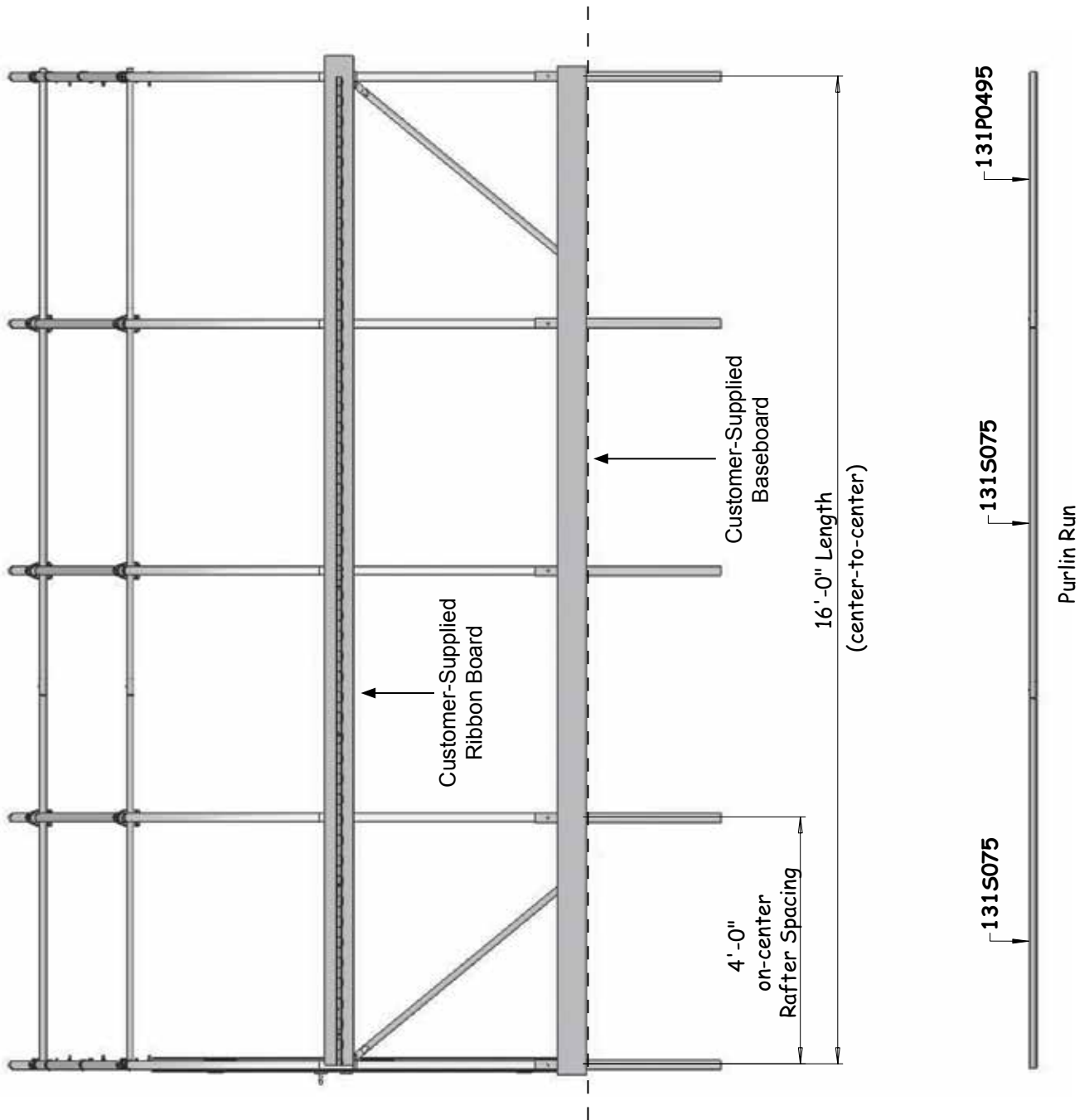

# SIDE PROFILE - 104841

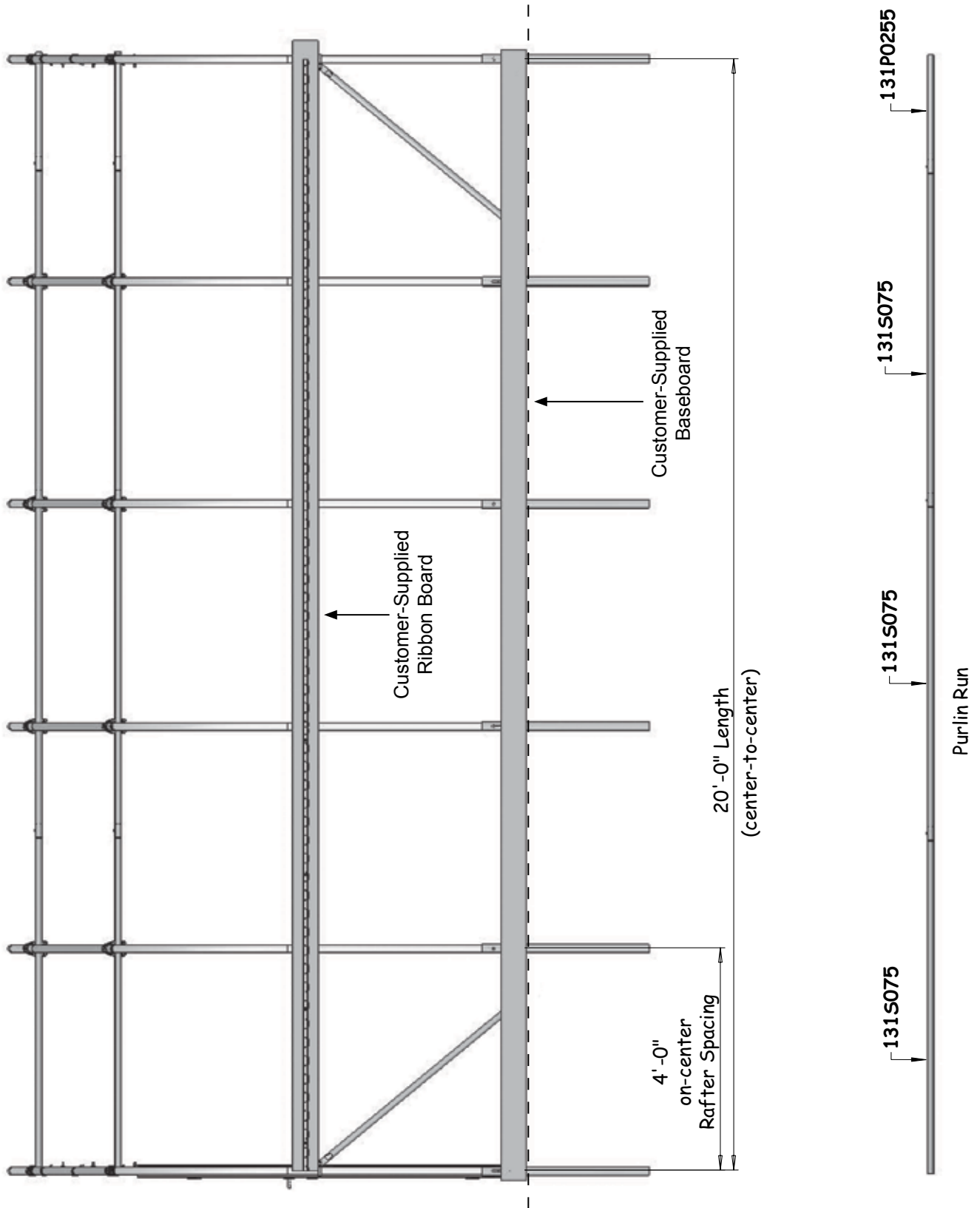

# SIDE PROFILE - 104842

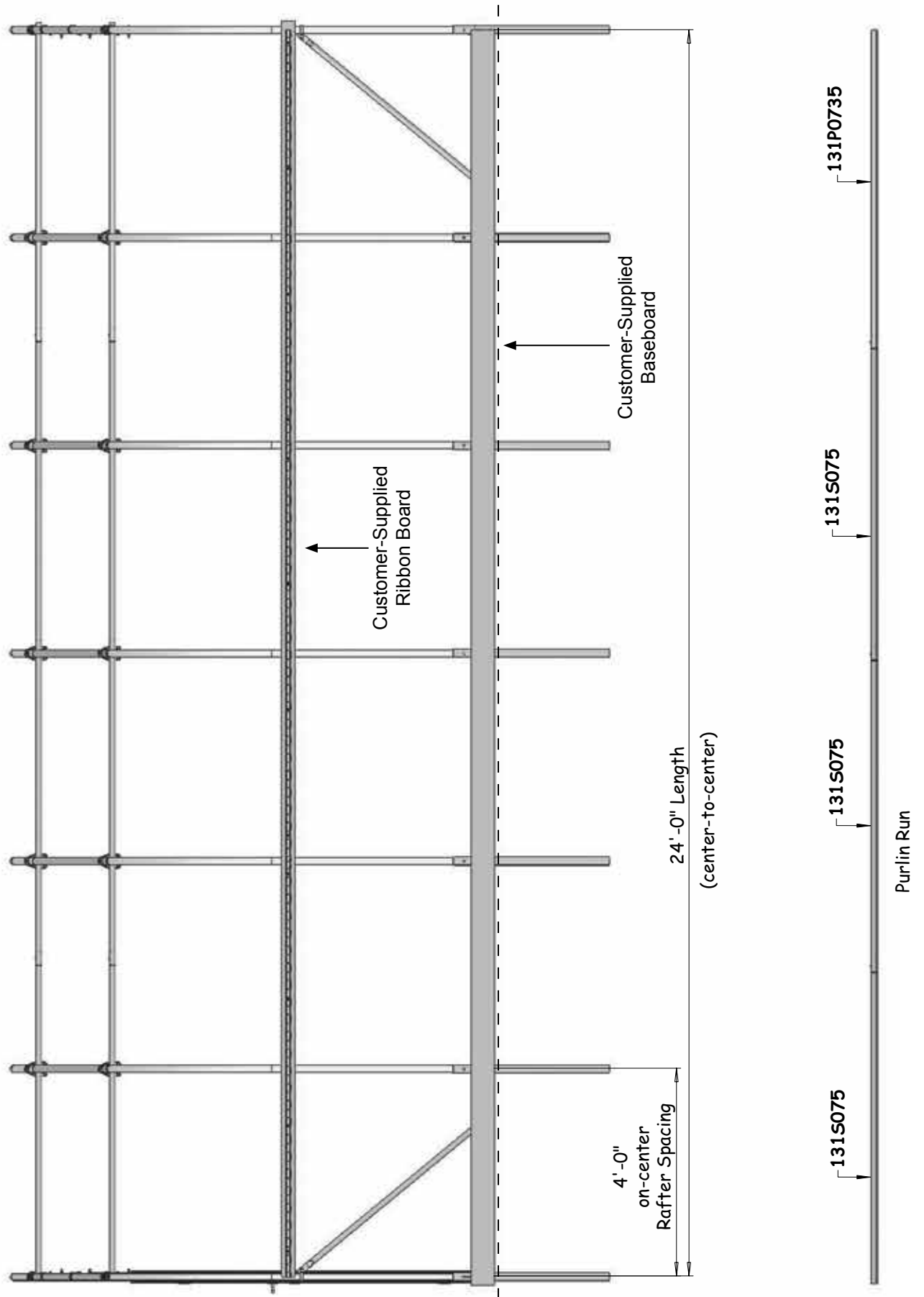

# SIDE PROFILE - 104843

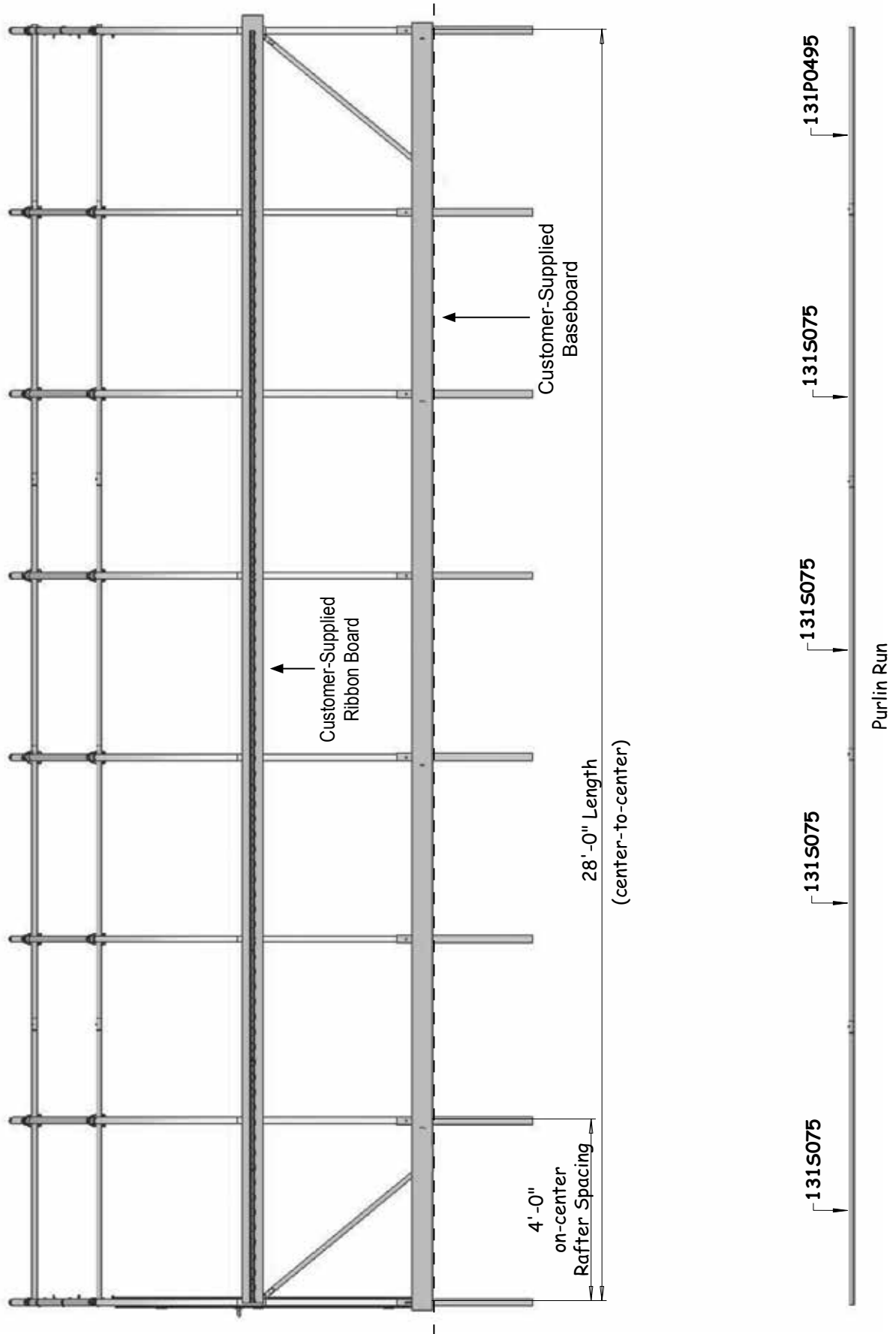

# CONNECTIONS

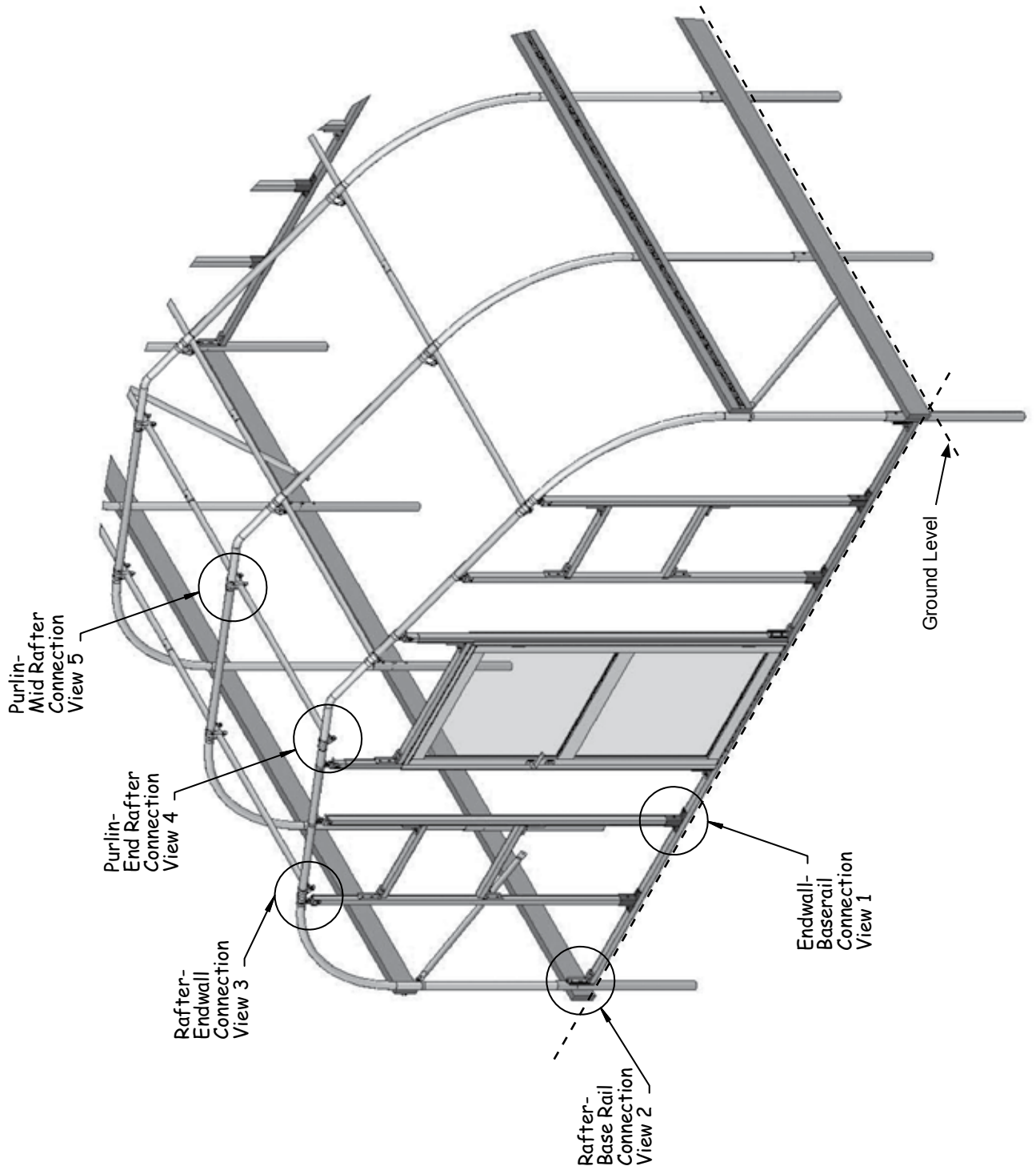

# CONNECTION - DETAILS

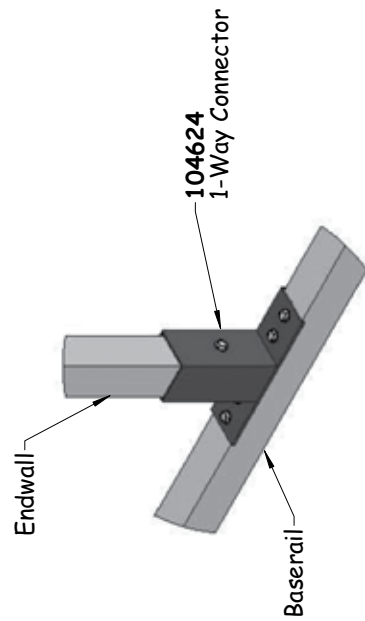

**View 1**  
Endwall- Baserail  
Connection

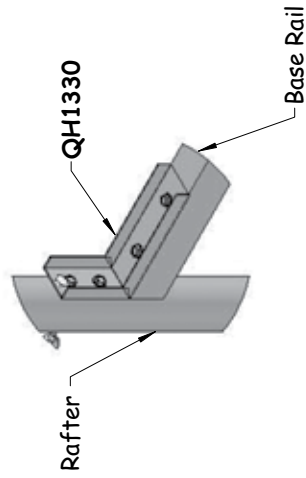

**View 2**  
Rafter- Base Rail  
Connection

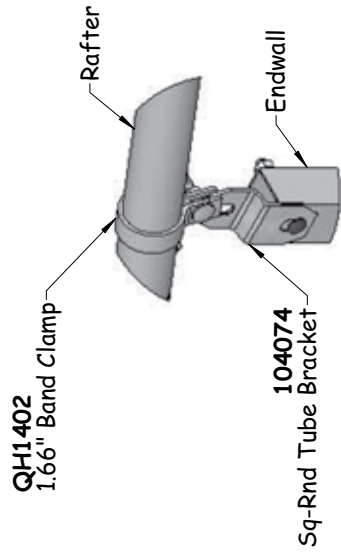

**View 3**  
Rafter- Endwall  
Connection

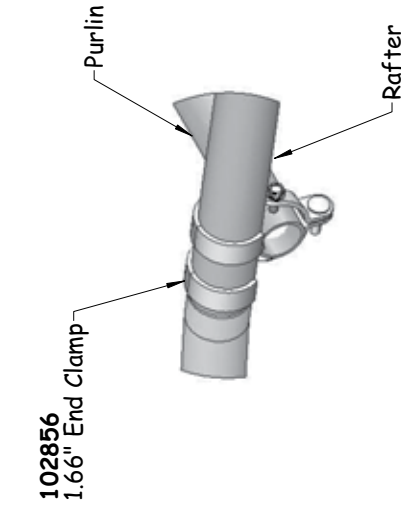

**View 4**  
Purlin- End Rafter  
Connection

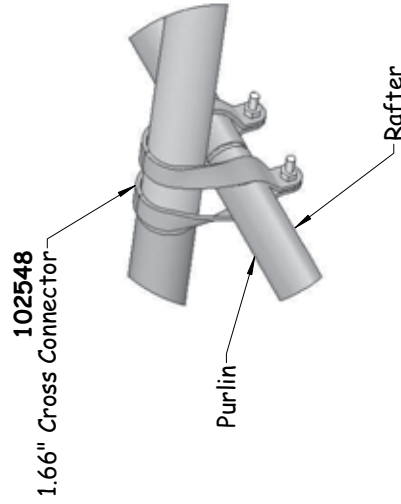

**View 5**  
Purlin - Mid Rafter  
Connection

# END FRAME DIAGRAM - FRONT VIEW

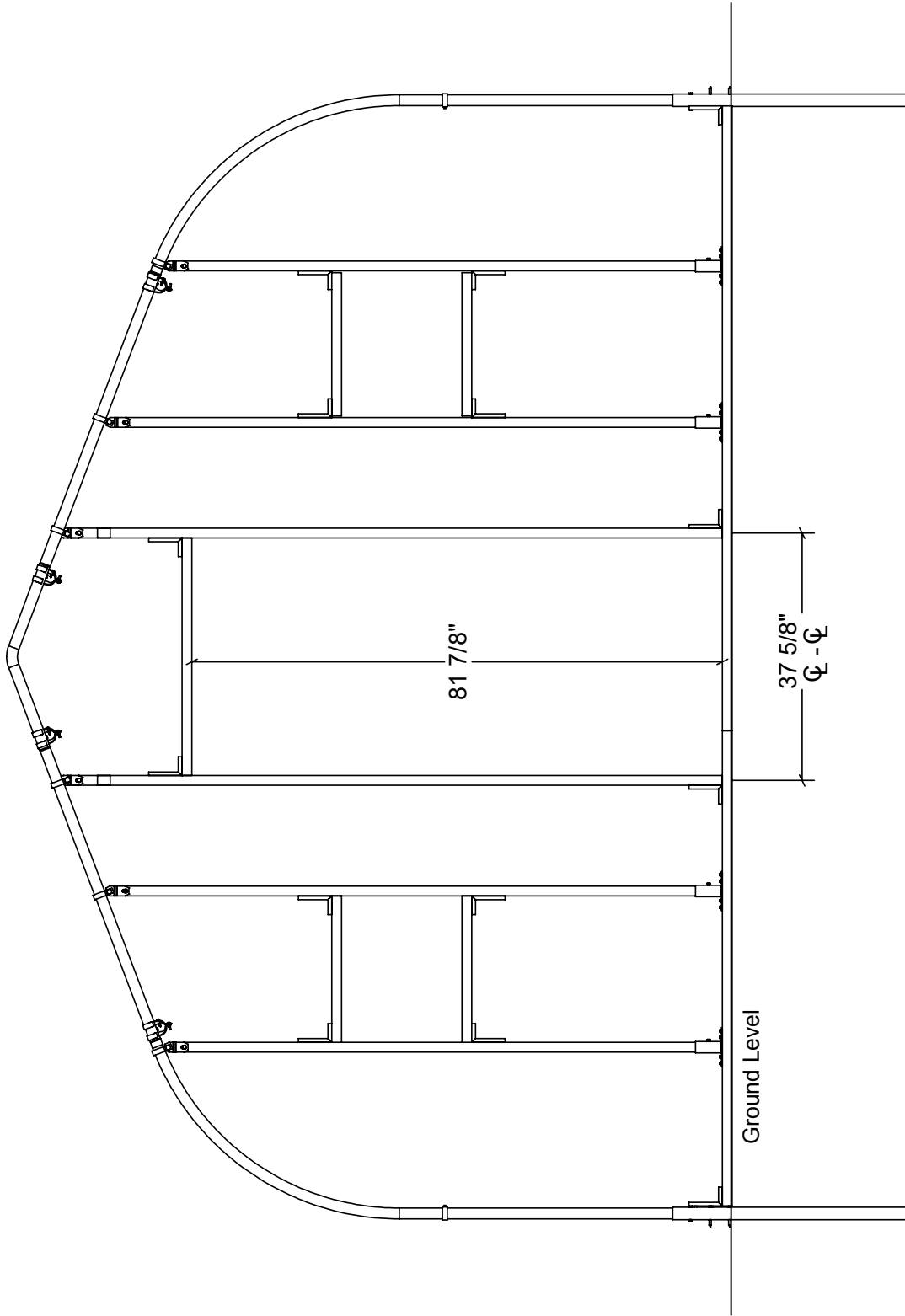

NOTE: COLUMNS NOT DIMENSIONED HAVE A NON-CRITICAL PLACEMENT AND ARE USED FOR POLYCARBONATE SUPPORT.

ALL END FRAMING TUBES ARE FULL LENGTH OR CUT FROM 1 1/2" X 1 1/2" SQUARE TUBING.

# END FRAME DIAGRAM - BACK VIEW

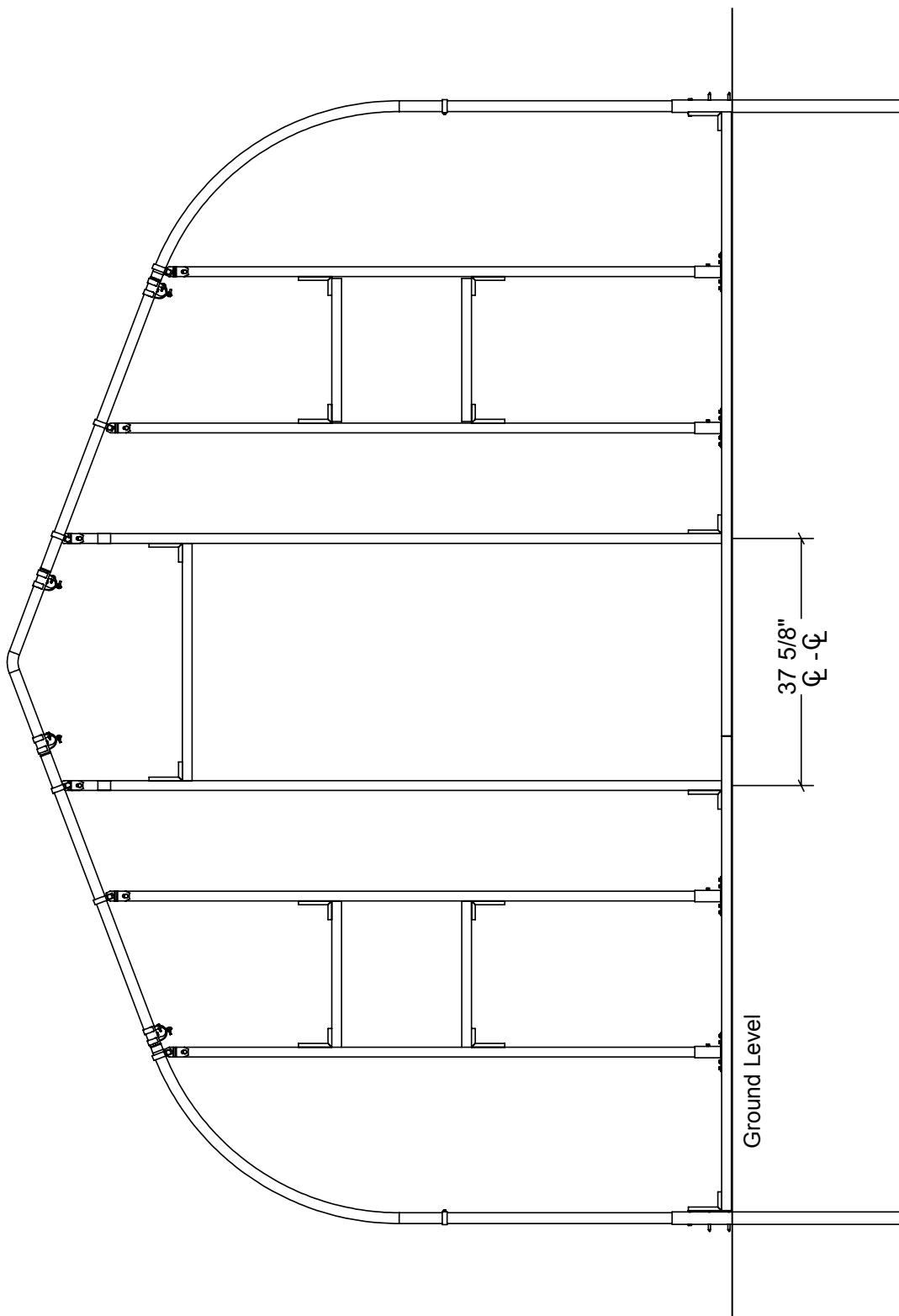

NOTE: COLUMNS NOT DIMENSIONED HAVE A NON-CRITICAL PLACEMENT AND ARE USED FOR POLYCARBONATE SUPPORT.

ALL END FRAMING TUBES ARE FULL LENGTH OR CUT FROM 1 1/2" X 1 1/2" SQUARE TUBING.

# H-CHANNEL INSTALLATION INSTRUCTIONS

The new H-channel design requires installation of the flat side facing out with channel side toward the building. Some diagrams and photos in this document show installation of *original* H-channel with channel side facing out. Design of new H-channel does *not allow* channel-side out installation.

Use the diagrams on this page to install H-channel with flat side facing out.

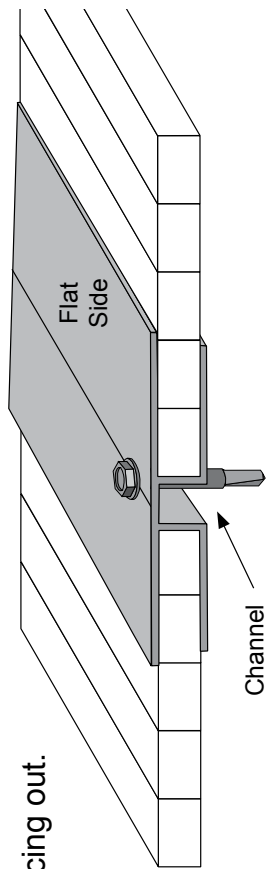

**⚠ ATTENTION:** Use only 1-1/2" Tek screws to attach H-channel to building frame. **Do not use shorter screws. They will not hold. Do not use washers on Tek screws when installing H-channel.**

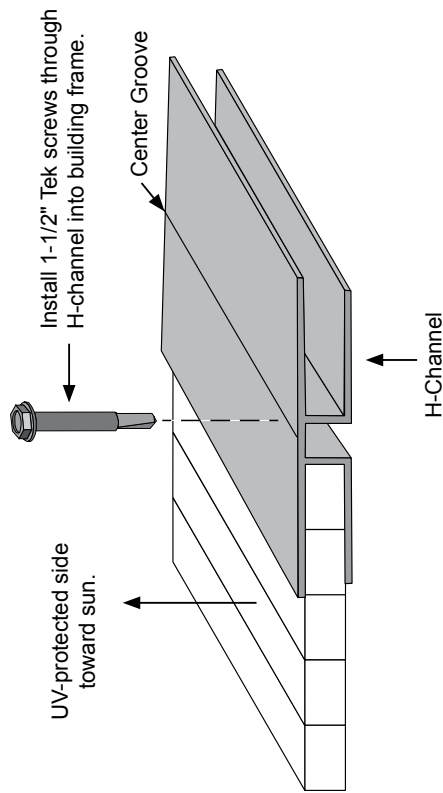
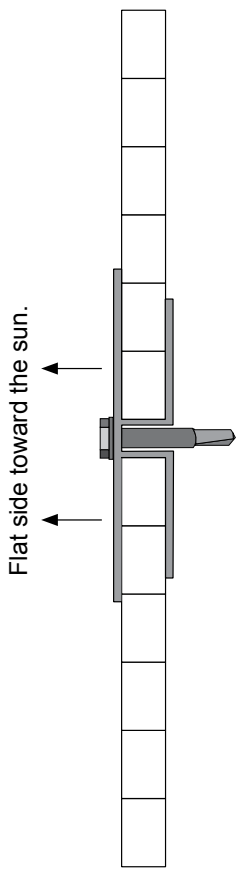

**⚠ ATTENTION:** Install all twin-wall poly carbonate panels with UV-protected side toward the sun.

# POLYCARBONATE PANELS - FRONT VIEW

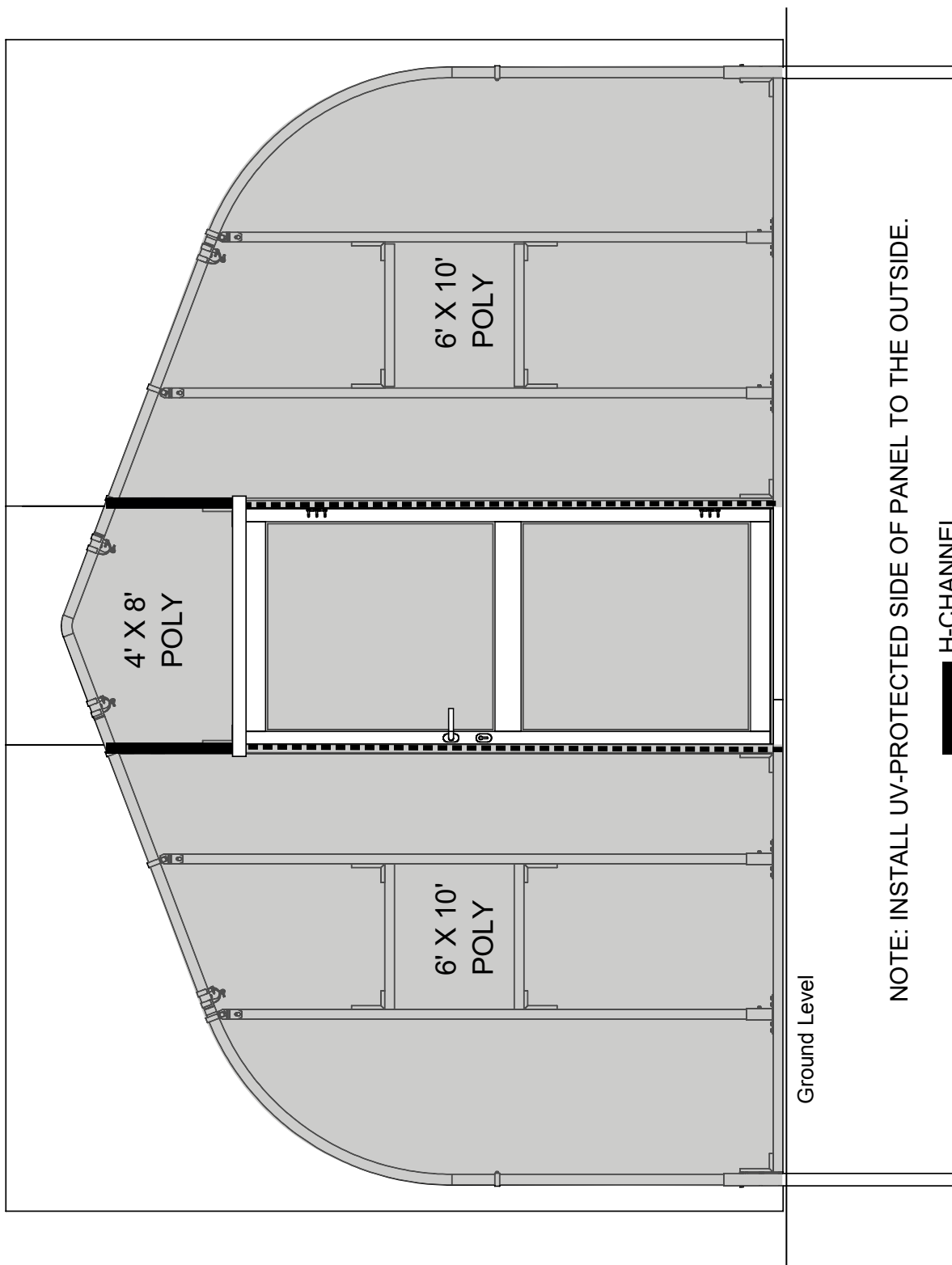

NOTE: INSTALL UV-PROTECTED SIDE OF PANEL TO THE OUTSIDE.

# POLYCARBONATE PANELS - BACK VIEW

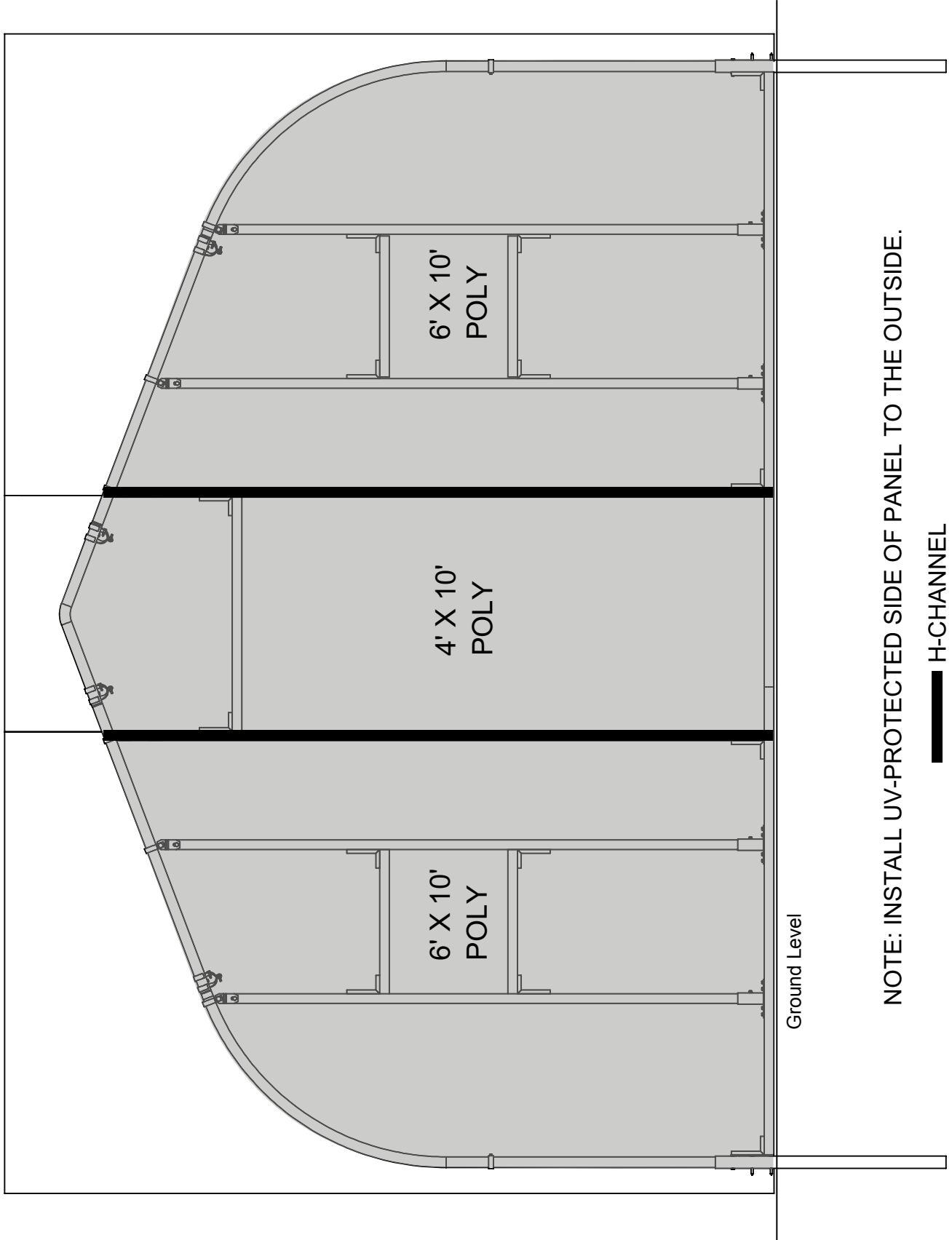

NOTE: INSTALL UV-PROTECTED SIDE OF PANEL TO THE OUTSIDE.

— H-CHANNEL