

FarmTek®

Chick-Inn Coops



Photo may show a different but similar model.

©2023 FarmTek®
All Rights Reserved. Reproduction
is prohibited without permission.



WARNING: Cancer and Reproductive Toxicity - P65Warnings.ca.gov

STK#	DIMENSIONS
104299	12' W x 18' L

Revision date: 05.03.23

FarmTek®

YOU MUST READ THIS DOCUMENT BEFORE YOU BEGIN TO ASSEMBLE THE SHELTER.

Thank you for purchasing this FarmTek® shelter. When properly assembled and maintained, this product will provide years of reliable service. These instructions include helpful hints and important information needed to safely assemble and properly maintain the shelter. Please read these instructions **before** you begin.

If you have any questions during the assembly, contact Customer Service for assistance.

SAFETY PRECAUTIONS

- Wear eye protection.
- Wear head protection.
- Wear gloves when handling metal tubes.
- Use a portable GFCI (Ground Fault Circuit Interrupter) when working with power tools and cords.
- Do not climb on the shelter or framing during or after construction.
- Do not occupy the shelter during high winds, tornadoes, or hurricanes.
- Provide adequate ventilation if the structure is enclosed.
- Do not store hazardous materials in the shelter.
- Provide proper ingress and egress to prevent entrapment.

ANCHORING INSTRUCTIONS

Prior to assembling this shelter, please read the **MUST READ** document included with the shipment.

⚠ WARNING: The anchor assembly is an integral part of the shelter construction. Improper anchoring may cause shelter instability and failure of the structure. Failing to anchor the shelter properly *will void the manufacturer's warranty* and may cause serious injury and damage.

LOCATION

Choosing the proper location is an important step before you begin to assemble the structure.

The following suggestions and precautions will help you determine whether your selected location is the best location.

- Never erect the structure under power lines.
- Identify whether underground cables and pipes are present *before* preparing the site or anchoring the structure.
- Location should be away from structures that could cause snow to drift on or around the building.
- Do not position the shelter where large loads such as snow and ice, large tree branches, or other overhead obstacles could fall.

SITE

After choosing a location, proper preparation of the site is essential. Follow the information below.

- *A level site is required.* The site must be level to properly and safely erect and anchor the structure.
- For sites that are not concrete or gravel, placing wood blocks or other suitable supports under each rafter leg helps prevent the pipes from sinking or working into the site.
- Drainage: Water draining off the structure and from areas surrounding the site should drain away from the site to prevent damage to the site, the structure, and contents of the structure.

⚠ WARNING: The individuals assembling this structure are responsible for designing and furnishing all temporary bracing, shoring and support needed during the assembly process. For safety reasons, those who are not familiar with recognized construction methods and techniques must seek the help of a qualified contractor.

ASSEMBLY PROCEDURE

Following the instructions as presented will help ensure the proper assembly of your shelter. Failing to follow these steps may result in an improperly assembled and anchored shelter and will void all warranty and protection the owner is entitled.

The steps outlining the assembly process are as follows:

1. Verify that all parts are included in the shipment. Notify Customer Service for questions or concerns.
2. Read these instructions, the Must Read document, and all additional documentation included with the shipment **before** you begin assembling the shelter.
3. Gather the tools, bracing, ladders (and lifts), and assistance needed to assemble the shelter.
4. Check the weather **before** you install the roof cover and any panels (if equipped). Do not install covers or panels on a windy or stormy day.
5. Re-evaluate the location and site based on the information and precautions presented in the documentation included with the shipment.
6. Prepare the site (if applicable).
7. Assemble the frame components in the order they are presented in these instructions.
8. Assemble the frame including the struts (if equipped).
9. Consult the MUST READ document and properly anchor the assembled frame.
10. Install, tighten, and secure the main cover and panels (if equipped). This applies to fabric covers that stretch over the frame assembly. Your shelter may include roof panels or side panels or both.
11. Read the Care and Maintenance information at the end of these instructions.

LIST OF WORDS AND PHRASES

Before you begin, it is important to become familiar with the words and phrases used in this instruction manual.

These words and phrases are common to most FarmTek® shelters and identify the different parts of the shelter. (Some are used in this document. Others may not apply to this particular shelter.) These terms describe the shipped parts and can also be found on the materials list/spec sheets included with the shipment. To aid in the assembly, read through the following definitions before you begin to assemble your shelter.

- **Conduit:** An assembly of pipes used to secure the main cover and end panels (if equipped). Purlins and some strut assemblies also consist of connected pipes to form a conduit. Each pipe joint of a conduit assembly is secured with a self-tapping Tek screw.
- **Coupler or Fitting:** A part of the frame assembly where legs, purlins and rafter pipes are inserted and secured. In most instances, 3-Way and 4-Way couplers are used. In some larger applications, couplers are used to secure the joints of the different rafter sections during the assembly of the rafters. Some shelters do not use couplers.
- **Foot or Rafter Foot:** The part attached to and found at the base of the rafter or leg of the shelter. Depending on the shelter, the foot is an optional purchase. Some shelters do not offer an optional foot. Some use 1-Way connectors.
- **Must Read Document:** This document includes building and shelter anchoring instructions, steps for end wall reinforcement, safety precautions, and notices and warnings. The Must Read document is sent with all shelters and buildings. If you did not receive a Must Read document, contact Customer Service to request one.
- **On-Center:** Term used to describe a measurement taken from the vertical center of the rafter or frame member to the vertical center of another.
- **Purlin:** The pipe assembly that runs perpendicular to the rafters or framework that supports the main cover. Purlins are found on the sides and roof areas of the assembled frame, are evenly spaced, and typically run from the front to the back of the shelter.
- **Plain or Straight Pipe:** A term used to describe a pipe that has the same diameter or width throughout its entire length.
- **Strut:** A strut is usually a length of pipe with two flattened ends and is used for diagonal bracing of the shelter frame. A strut is typically secured to the frame work by special brackets and bolts.
- **Swaged End or Swaged Pipe:** The term “swaged” refers to the tapered end of the pipe or tube. Swaged ends of a pipe can be inserted into couplers and the straight ends of other pipes.
- **Tek screw:** A self-tapping fastener used to secure pipe joints and to fasten brackets to rafters.

CHICK-INN

REQUIRED TOOLS

The following list identifies the main tools needed to assemble the shelter. Additional tools and supports may be needed depending on the structure, location, and application.



Space below is reserved for customer notes.

- Tape measure or measuring device
- Magnetic nut setter (5/16" x 2-9/16")
- Tools to install anchor systems (additional purchase is required. Consult the Must Read document.)
- Variable speed drill and impact driver (cordless with extra batteries works best)
- Wrench, ratchet and socket (recommended)
- Eye protection and gloves to handle metal pipe
- Duct tape (optional and supplied by customer)
- Box cutter or utility knife

UNPACK AND IDENTIFY PARTS

The following steps will ensure that you have all the necessary parts before you begin to assemble the shelter.

1. Unpack the contents of the shipment and place where you can easily inventory the parts. Refer to the Bill of Materials/Spec Sheets.
2. Verify that all parts listed on the Bill of Materials/Spec Sheets are present. If anything is missing or you have questions, consult the Pictorial Parts Guide and all shelter diagrams for clarification, or contact Customer Service.

NOTE: At this time, you do not need to open the plastic bags containing smaller parts such as fasteners or washers.

FarmTek®

The following graphics and photos will help you identify the different parts and show you how they are used.
(Not all parts are shown.)



FA4470B
Tek Screw



QH1061
Ratchet

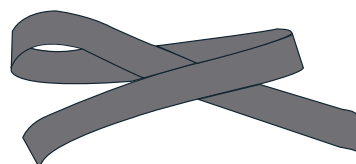

103620b
Plain End Strap



102191
3-Way Coupler

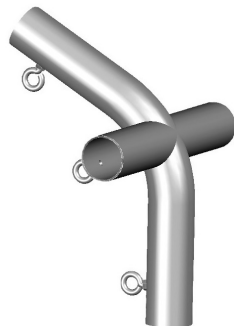

102192
4-Way Coupler

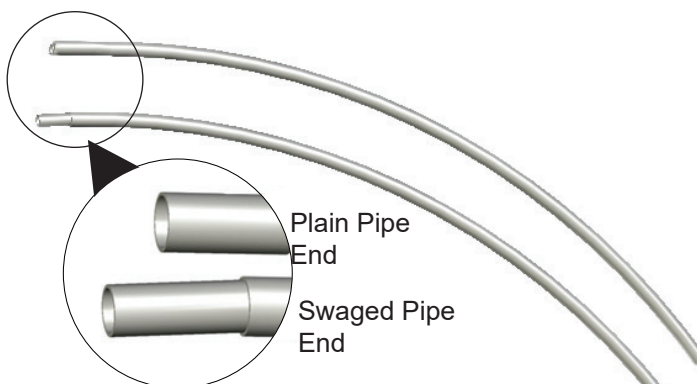

Swaged and plain pipe ends used to show the difference.
Pipe shape may differ from actual pipe used for the shelter.

CHICK-INN

ADDITIONAL PARTS IDENTIFICATION NOTES

In some instances, there can be differences between the parts that are shown and referenced in the instructions and the parts that are shipped with the shelter. These differences *do not* affect the integrity of the shelter, but can change the assembly procedures.

The information that follows identifies possible changes in the assembly procedure found in this instruction document. *Please implement these changes during the assembly of the shelter.*

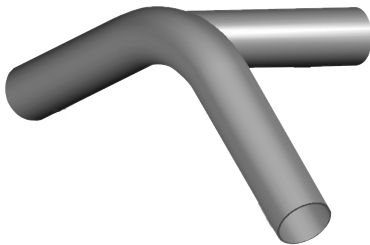

3-Way Coupler (no lock bolt)

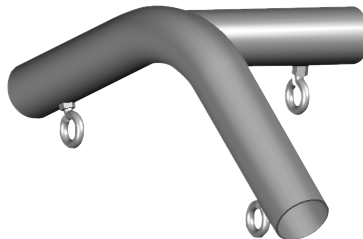

3-Way Coupler (includes lock bolt)

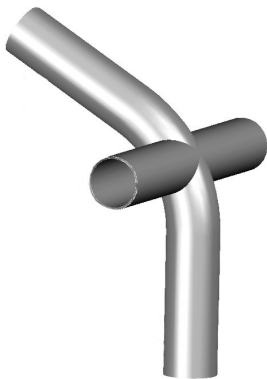

4-Way Coupler (no lock bolt)

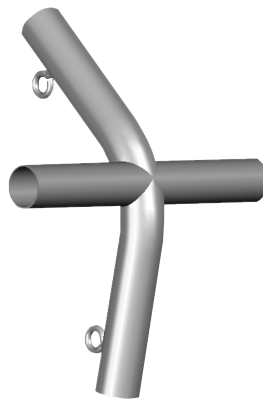

4-Way Coupler (includes lock bolt)

There can be two types of couplers used during the assembly of the shelter: those that include an installed locking eyebolt and those that do not. See above.

If the couplers included with your shelter do not have an installed lock bolt, use a *self-tapping Tek screw* to secure the different pipes to the couplers during the assembly process. The self-tapping Tek screws are included with the shipment.

ATTENTION: Tek screws are sent with all shelters of this type. For couplers with locking eyebolts, install the Tek screws at each pipe connection for additional security if desired.

⚠ WARNING: To prevent personal injury and damage to the shelter, *fasten and tighten a Tek screw* at each pipe and coupler joint.

To prevent cover damage, install the Tek screw so that it *does not* touch the main cover or any optional side or end panels once these are installed.



Chick-Inn Coops

OVERVIEW

This section is an overview of the process for assembling your Chick-Inn Coop. See illustration below to identify main parts of shelter.

1. Locate the required parts for each assembly procedure.
2. Assemble the rafters and frame, and square frame.
3. Anchor the shelter.
4. Prepare and attach main cover.

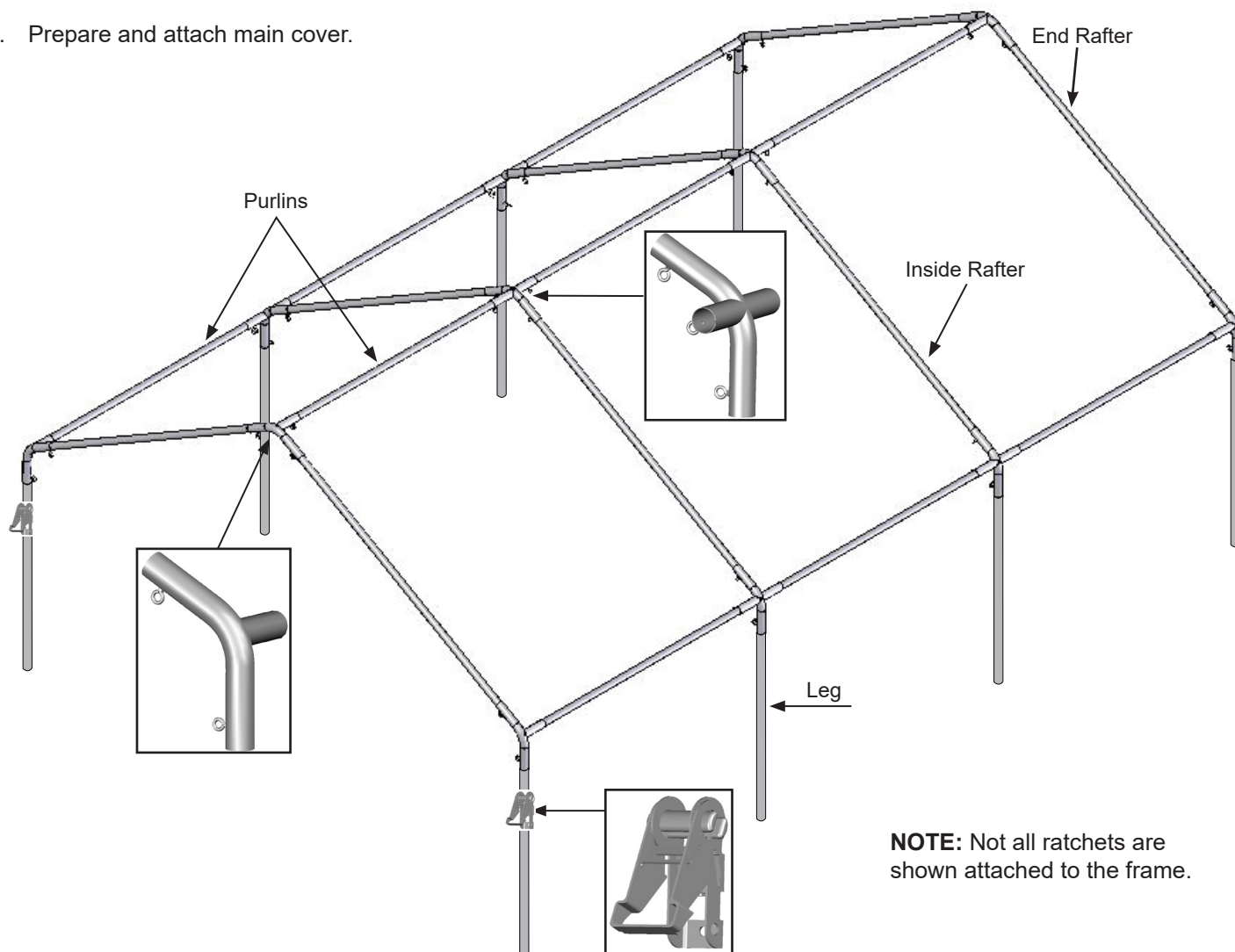

NOTE: Not all ratchets are shown attached to the frame.

CHICK-INN

LAY OUT THE BUILDING SITE

After the site is prepared, identifying the location of the shelter corners helps to square the frame after it is assembled.

Taking these steps **before** assembling the shelter saves time and ensures that the structure is positioned as desired. The following procedure is a suggested method. Its use depends on the size of the shelter, shelter application, the footings, and the method used to anchor the shelter.

SQUARE THE SITE

1. Identify where a corner of the building will be positioned, drive in a stake. String a line the exact width of the building and drive another stake.
2. String a line 90 degrees from the string at least as long as the building and drive a stake at one back corner.
3. Measure the width and length of the building and drive the final corner stake.

NOTE: A transit can be used to ensure an accurate 90° angle, or the 3-4-5 rule can be used. Refer to diagram. Using multiples of 3-4-5 such as 6-8-10 or 12-16-20 helps to maintain an accurate 90° angle.

4. After squaring the position of the building and placing a stake at all corners, string a line between the stakes to mark the base of the building.

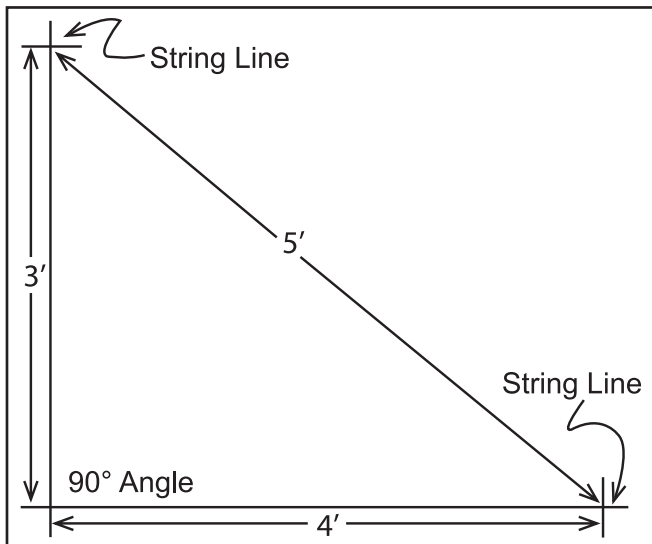

RAFTER ASSEMBLY

Gather the parts:

- Pipes 1.315" x 78" Plain (#131P078)
- Pipes 1.315" x 72" Plain (#131P072)
- 3-Way Couplers (#102191)
- 4-Way Couplers (#102192)

Rafter Assembly Procedure

Arrange the roof pipes on the ground adjacent to the correct couplers needed to assemble the roof.

1. Connect the ridge pipes (72" purlin section) using a 3-Way coupler on each end and 4-Way couplers between the sections. The length should match your shelter length.

NOTE: The last ridge pipe will finish with a 3-Way coupler.

2. Attach the rafter pipes as shown in the illustration. Rafter pipes are 78".

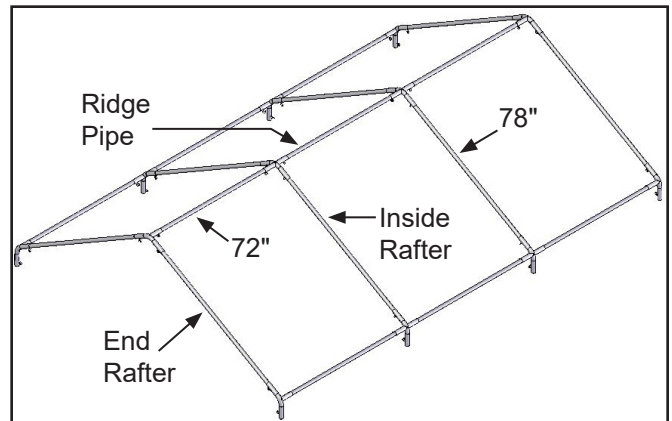

3. Connect the 3-Way couplers to assemble the end rafters of the roof assembly and connect the 4-Way couplers to construct the inside rafters.

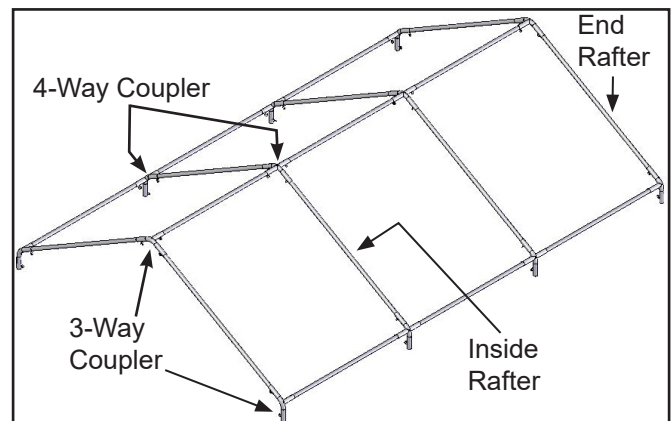

NOTE: Position the couplers with the eye bolts inside the frame.

RAFTER ASSEMBLY (CONTINUED)

Lower Leg Assembly

Gather the parts:

- Lower leg pipes 24" (#131P024)

With the roof frame assembled, connect the 24" lower leg pipes to the assembly as instructed below:

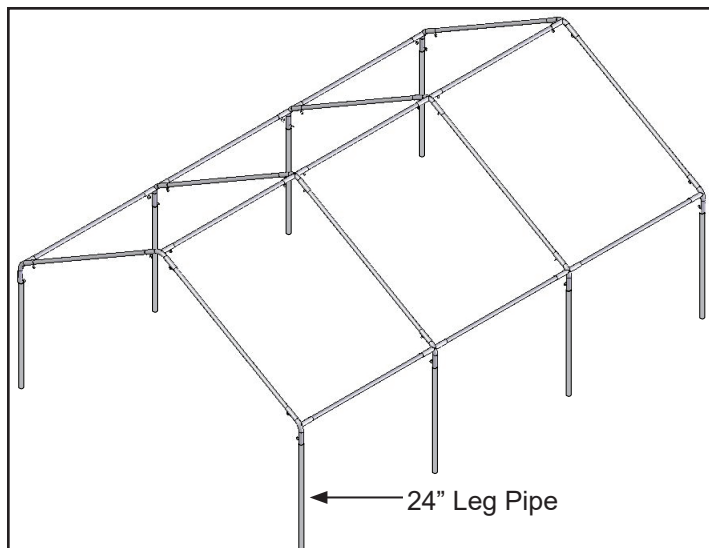

1. Lift one side of the assembled frame and slide the 24" lower leg pipe into the 3-Way and 4-Way couplers.

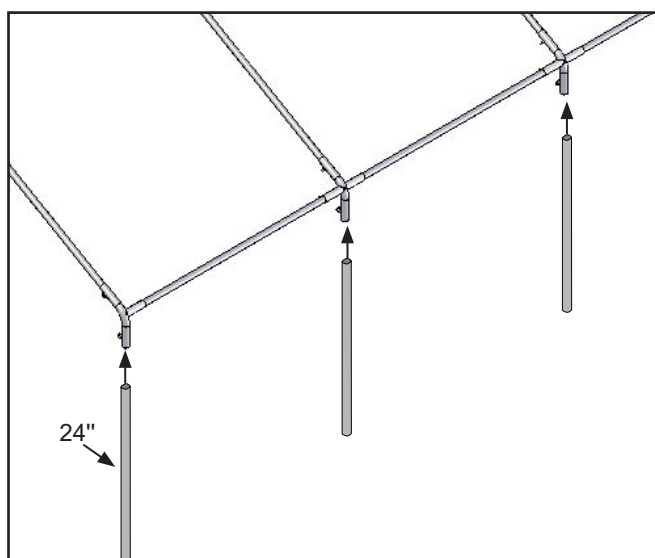

2. Secure the leg pipes in the couplers as needed using the locking eye bolts.
3. Repeat steps to install the leg pipes for the remaining side of the assembly.
4. Verify that all eye bolts are tight and square the frame.

SQUARE THE ASSEMBLED FRAME

Gather the parts:

- Measuring tape

Complete these steps:

1. With the frame in position, perform a final square of the frame by measuring diagonally (corner-to-corner shown below) at the bottom of the legs and verify that the two measurements are equal. Adjust if needed.

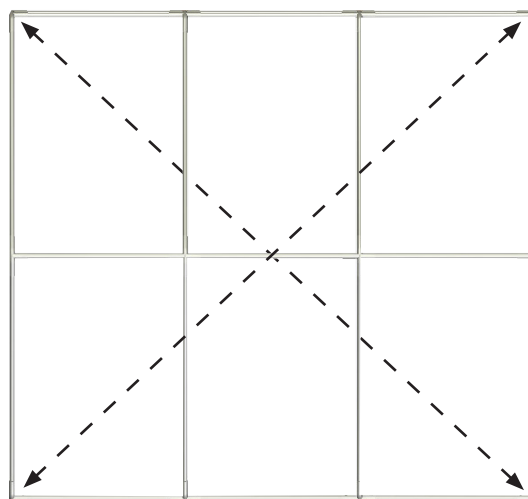

FRAME TOP VIEW

2. Adjust width. Measure width from center of rafter leg to center of other rafter leg of the same rafter assembly. Adjust if needed. Repeat for all rafter assemblies.

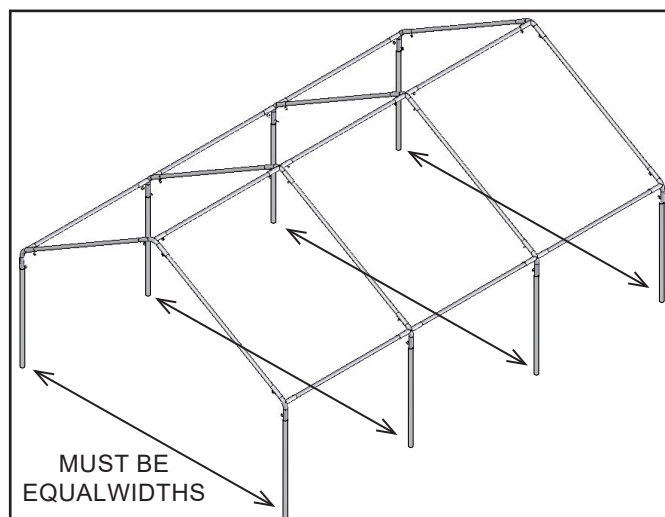

3. Examine the frame and remove any sharp edges from the frame, or reposition screws (if equipped) so they do not come in contact with the roof cover.
4. After the frame is squared, read or reread the MUST READ document and anchor the shelter.

CHICK-INN

ANCHOR THE SHELTER

At this point, anchor the shelter. Consult the MUST READ document for anchoring information and suggestions. Please call customer service at 1-800-245-9881 for additional anchoring information.

⚠ CAUTION: The anchor assembly is an integral part of the shelter construction. Improper anchoring may cause shelter instability and failure of the structure to perform as designed. Failing to anchor the shelter properly will void the manufacturer's warranty and may cause serious injury and damage.

INSTALL COVER

Gather the parts:

- Ratchets (1" 4000lb)
- Pipe 1.315" x 75" Swaged (#131S075)
- Pipe 1.315" x 72" Plain (#131P072)
- Cover and ropes long enough to reach over the frame (supplied by customer). May not be needed for some frame designs and lengths.
- Tek screws and magnetic nut setter (5/16" x 2-9/16")

NOTE: Each main cover conduit consists of two (2) 1.315" x 75" (#131S075) swaged pipe and one (1) 1.315" x 72" (#131P072) plain pipe.

⚠ WARNING: To prevent damage to the cover and to prevent serious personal injury, DO NOT attempt to install the cover on windy days.

1. Select the required pipe sections for one main cover conduit and connect these by inserting the swaged ends of the pipes into the plain ends until the conduit is assembled. Secure each pipe joint with a Tek screw and wrap the joint with duct tape (supplied by customer). Repeat this step for the remaining conduit.

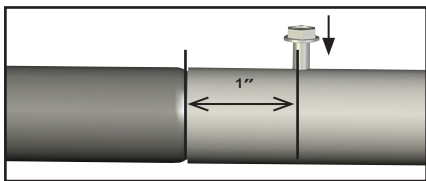

These cover conduits are inserted into pockets in the cover and are used to tighten and secure the cover.

2. After assembling the cover conduits, locate the cover and unfold it along the side of the frame.

NOTE: When handling the cover and setting it in position, do not pull on the end straps. They will pull out of the cover.

3. Locate the cover ends with strapping and align cover with the front and back of the shelter.

4. Insert the cover conduits into the pockets of the cover.

NOTE: Do not insert the conduits into the pocket that includes the strap, which is at the front and back.

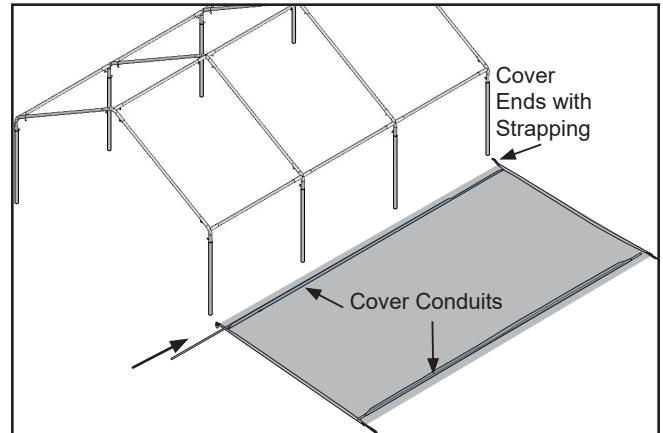

5. To pull the cover over the frame, attach ropes to both ends of the cover conduit. Wrap the rope around the conduit a few times to prevent it from slipping off.

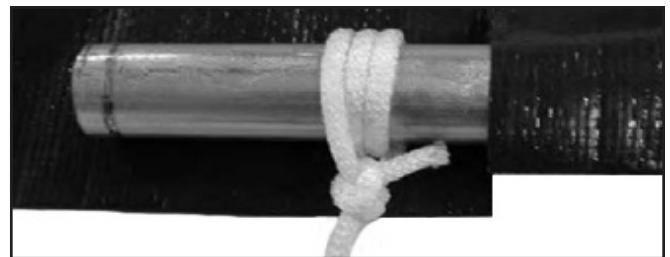

NOTE: Depending on the length of the cover it may be necessary to attach additional ropes to the cover conduit between the end ropes by cutting a small opening in the cover pocket and tying the rope around the conduit. *Cut through the conduit pocket only. Rope may not be needed for some cover and frame designs.*

6. With all ropes attached to the cover conduit, lift the conduit and carry the cover toward the base of the frame.
7. Toss the ropes over the frame and pull the cover into position. One person is required at each rope.

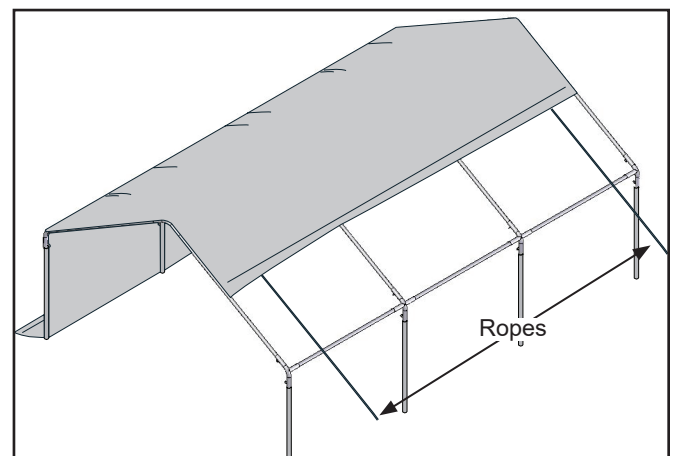

INSTALL COVER (CONTINUED)

8. Center the cover on the frame front to back and side to side.
9. In the front and rear hems, locate the cover straps. Using the straps as guides, fasten ratchets to the outside of the end rafter legs using a Tek screw.

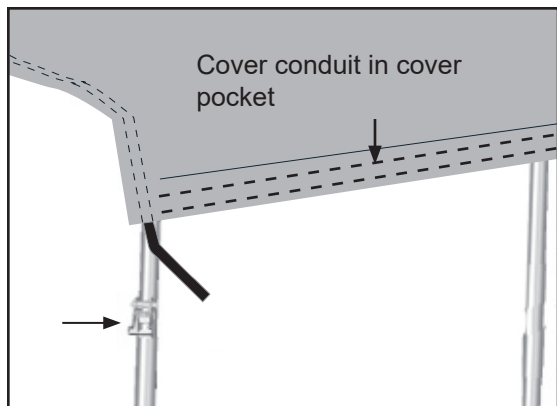

NOTE: Allow a few inches to remain between the end of the cover and the ratchet. Temporarily secure the cover to the frame if needed to prevent it from moving in the wind. *Do not leave a loose cover unattended.*

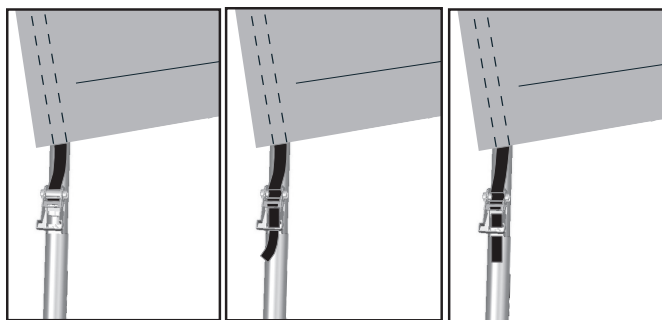

10. Thread the strap end into each ratchet and slightly tighten.

NOTE: It may be necessary to remove excess strap if it binds up in the ratchet.

11. Using the cover conduit as a guide, attach the remaining ratchets to the interior rafter legs at the proper height. Fasten ratchets to the outside of these rafters using Tek screws.

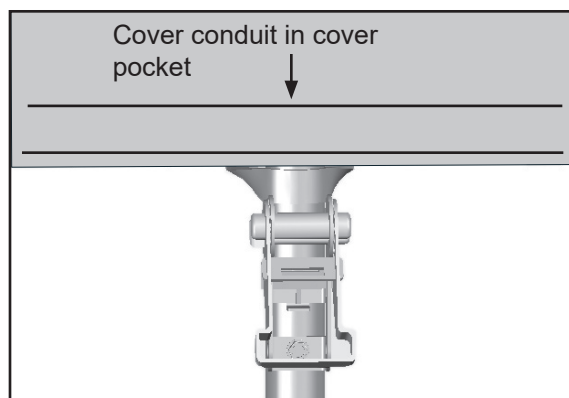

12. Cut a slit through the main cover pocket at the rafter position where the ratchets are installed. Insert a 3' section of strap through the slit and around the cover conduit for each ratchet.

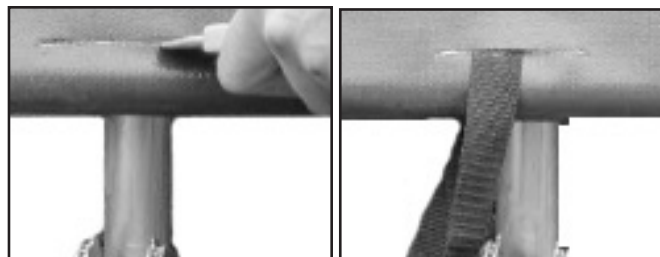

13. Thread the strap ends into a ratchet and slightly tighten.

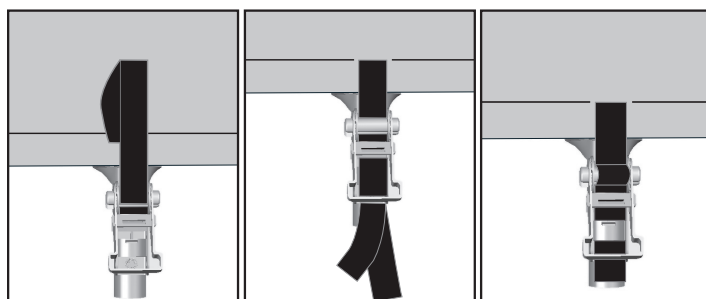

NOTE: It may be necessary to remove excess strap if it binds up in the ratchet.

14. Repeat the steps for the remaining ratchets.
 15. Using additional help (if needed) tighten the cover beginning with the ratchets along the sides of the shelter frame. Tighten all ratchets evenly.
- NOTE:** Loosen the ratchets if need to center the cover or remove excess strap and retighten.
16. With all side ratchets tightened, tighten the end ratchets to secure the bonnet portion of the main cover.
 17. Read the care and maintenance information that follows.

CHICK-INN

SHELTER CARE AND MAINTENANCE

Proper care and maintenance of your shelter is important. Check the following items periodically to properly maintain your shelter:



Space below is reserved for customer notes.

- Regularly check the main cover and panels (if equipped) to see that these remain tight and in proper repair.
- Check connections and all fasteners to verify that they remain tight.
- Do not climb or stand on the shelter at anytime.
- Remove debris and objects that may accumulate on the shelter. Use tools that will not damage the cover when removing debris.
- Remove snow to prevent excess accumulation. Use tools that will not damage the cover when removing snow.
- Check the contents of the shelter to verify that nothing is touching the cover or the side panels that could cause damage.
- Check the anchoring system to ensure that all components are tight and in good repair.
- If the shelter is moved, inspect all parts and connections before reassembling.
- For replacement or missing parts, call 1-800-245-9881 for assistance.

NOTE: With the exception of Truss Arch buildings, FarmTek® shelters and greenhouses do not have any tested loading criteria.



Space below is reserved for customer notes.